

HeartBeat HandBall



**EHF SCIENTIFIC
CONFERENCE 2011**

EHF Scientific Conference 2011

Science and Analytical Expertise in Handball
(Scientific and practical approaches)

18 – 19 November 2011
Vienna, Austria

EUROPEAN HANDBALL FEDERATION

ISBN 987-3-9503311-0-3

EHF Scientific Conference 2011

Science and Analytical Expertise in Handball

(Scientific and practical approaches)

18-19 November 2011

Vienna, Austria

EUROPEAN HANDBALL FEDERATION

Editor (responsible for content): EHF Methods Commission (Frantisek Taborsky)
Place of Publication: European Handball Federation, Hoffingergasse 18, A-1120 Vienna, Austria
<http://www.eurohandball.com/>
Co-ordination: Anna Psintrou, Helmut Höritsch
Lay-out: Richard Turner
Printed by: Druck Hofer GmbH, 2054 Haugsdorf, Leopold-Leuthner-Str.2, Austria; Josef Stöger
Publication: November 2011
© EHF

Table of Contents

Table of Contents	1
Editorial	5
KEYNOTE	
<i>Taborsky, F.</i>	
Phenomenon Handball: Introductory Lecture at the EHF Scientific Conference "Science and Analytical Expertise in Handball"	7
HUMANITIES	
<i>Arfa, Y. - TUN</i>	
Personality Traits as Predictors of Physical Capacities Development	14
<i>Bideau, B.; Vignais N.; Kulpa R.; Craig C. and Delamarche P. - FRA</i>	
Do the Kinematic of the Throwing Action in Handball Influence Goalkeeper's Judgement?	19
<i>Dumitriu, D.L. - ROU</i>	
Social Representations of Handball Coaches' Role	25
<i>Dumitriu, D.L. - ROU</i>	
The Importance of Roles' Dynamics Inside a Team	31
<i>Estriga, M.L.; Costa, J.M.; Melo, A. and Fazendeiro Batista, P.- POR</i>	
Decision Making in Portuguese Handball Referees	37
<i>Estriga, M.L.; Marques de Carvalho, João; Bernandez, J. and Massada, L. - POR</i>	
Muscle Strength and ACL Injury in Portuguese Female Handball Players	42
<i>Ferreira, A.L.; Fazendeiro Batista, P. and Estriga M.L. - POR</i>	
Handball Teaching at School – a Pre-Service Teaching Experience Based on the Sport Education Model	48
<i>Sosa, P.I. and Oliver, J.F. - ESP</i>	
Competitive Anxiety and Stress in Young Handball Players	54
<i>Sosa, P.I. and Oliver, J.F. - ESP</i>	
Psychological Characteristics of Young Handball Players and its Importance for Handball Coaches	58
<i>Sosa, P.I. and Oliver, J.F. - ESP</i>	
Psychological Variables Related to Motivation among Young Athletes of Handball Who Practise Competition Sport	63
<i>Hörtsch, H. - AUT</i>	
Handball at School – Didactical Guidelines for Physical Education (P.E.) Students and Teachers	68
<i>Kajtna, T.; Pori, M.; Justin, I. and Pori, P. - SLO</i>	
Psychological Characteristics of Slovene Handball Goalkeepers	73
<i>Luig, P. and Henke, T. - GER</i>	
Acute Injuries in Handball	78
<i>Luig, P. and Henke, T. - GER</i>	
Injury Prevention in Handball	84
<i>Marczinka, Z. - HUN</i>	
What's the Difference? – Coaching Female and Male Handball Players	89
<i>Petronijevic, M. - SRB</i>	
Mini Handball - Handball as School Project in Serbia	94
<i>Pollany, W. - AUT</i>	
The Position of Mirror Neurons in Linking Applied Psychology and Applied Pedagogy	98

<i>Rivilla, J.; Lorenzo, J.; Ferro, A. and Sampedro, J. - ESP</i>	
Effect of the Decision Making Process in the Speed of Defensive Displacement in Handball	101
<i>Rivilla, J.; Lorenzo, J.; Ferro, A. and Sampedro, J. - ESP</i>	
Effect of New Technologies on the Ability to Analyze Situations Sports in University Students	104
<i>Vila, H.; Rodríguez, F.; Fernandez, J. and Ferragut, C. - ESP</i>	
Multidimensional Evaluation of Handball Players: Talent Selection by Discriminant Analysis	108
<i>Vila, H.; Rodríguez, F.; Vázquez, I. and Fernández, J. - ESP</i>	
Multidimensional Evaluation of Young Handball Players: Discriminant Analysis Applied to Talent Selection	112
NATURAL SCIENCES	
<i>Acsinte, A. - ROU</i>	
Proprioceptive Training in Handball	116
<i>Bon, M.; Bračič, M.; Šibila, M. and Pori P. - SLO</i>	
Handball Team Staff Heart Rate Monitoring during Women's Champions League Match	121
<i>Oliver, J.F. and Sosa, P.I. - ESP</i>	
Study of the Proportion between Women and Men's Balls of Handball and the Measurement of the Hand of Women and Men Handball Players	126
<i>Delamarche, P. and Bideau, B. - FRA</i>	
Relevance of Biological and Biomechanical Analysis in Handball Performance	129
<i>Gutiérrez, O.; Contreras, J.; Saaverda, M.; Fernández, J.J.; Acsinte, A.; Hernández, M. and Vazquez I. – ESP / ROU</i>	
Influence of Birth Year of Arrival at Elite Handball Male in Junior and U18's	135
<i>Hantău, C.; Tonița, F.; Pascal, A. and Hantău Cr. - ROU</i>	
Influence of the Interpersonal Relationship on the Efficiency of the Attack for the Women Handball Teams	139
<i>Justin, I.; Pori, M.; Kajtna, T. and Pori, P. - SLO</i>	
The Differences in the Selected Morphological Characteristics and Motor Abilities between the Slovenian Handball Goalkeepers and Students of Faculty of Sports	144
<i>Manchado, C.; Ferragut, C.; Abraldes, A.; Rodriguez, N.; Alcaraz, P. and Vila H. - ESP</i>	
Ball Speed in Women Handball Players: Analysis of Different Playing Positions	148
<i>Manchado, C. and Platen, P. – ESP / GER</i>	
Time-Motion Analysis and Physiological Demands in International Women's Team Handball	151
<i>Massuça, L.M. - POR</i>	
The Relative Age Effect in Body Size and Success of World-Class Handball Players	156
<i>Michalsik, L.B.; Madsen, K. and Aagaard, P. - DEN</i>	
Activity Match Profile and Physiological Demands in Female Elite Team Handball	162
<i>Michalsik, L.B.; Aagaard, P. and Madsen, K. - DEN</i>	
Match Performance and Physiological Capacity of Male Elite Team Handball Players	168

<i>Michalsik, L.B.; Aagaard, P. and Madsen, K. - DEN</i>	
Technical Activity Profile and Influence of Body Anthropometry in Male Elite Team Handball Players	174
<i>Michalsik, L.B.; Madsen, K. and Aagaard, P. - DEN</i>	
Technical Match Characteristics and Influence of Body Anthropometry in Female Elite Team Handball Players	180
<i>Póvoas, S.C.; Soares, J.M. and Rebelo A. - POR</i>	
Activity Motor Pattern and Heart Rate during Elite Team Handball Matches	186
<i>Póvoas, S.C.; Soares, J.M. and Rebelo A. - POR</i>	
Metabolic Profile of Elite Team Handball	191
<i>Šibila, M.; Bon, M.; Mohorič, U. and Pori P. - SLO</i>	
The Relation between Percentage of Body Fat and Measures of Running Speed, Jump Power and VO _{2max} Consumption in Slovenian Junior Elite Handball Players	194
<i>Tůma, M.; Zahálka, F. and Malý, T. - CZE</i>	
Postural Stability of Elite Women's Handball Players	198
<i>Tůma, M. and Vozobulová, P. - CZE</i>	
Somatic Characteristics of Selected Youth Female Players by Czech Training Centres	204
<i>Urban, F.; Kandrác, R. and Taborský, F. – SVK / CZE</i>	
Position-Related Changes in Anthropometric Profiles of Top Male Handball Players: 1980 and 2010	208
<i>Urban, F.; Kandrác, R. and Taborský, F. – SVK / CZE</i>	
Position-Related Changes in Somatotypes of Top Level Male Handball Players: 1980 and 2010	214
<i>Vila, H.; Machado, C.; Abraldes, A.; Alcaraz, P.; Rodríguez, N. and Ferragut, C. - ESP</i>	
Anthropometric Profile in Female Elite Handball Players by Playing Positions	219
<i>Visnapuu, M.; Jürimäe, T.; Jürimäe, J. and Allikivi P. - EST</i>	
Relationship between High Level Young Handball Goalkeepers' Playing Characteristics and Body Composition	223
TRAINING AND THE GAME	
<i>Belka, J.; Hulka, K.; Svoboda, Z. and Kostelnik V. - CZE</i>	
Load Intensity Comparison of Woman Players Aged 17-18 in Competitive and Warm-Up Matches in Handball	228
<i>Bon, M.; Doupona Topič, M.; Šibila, M.; Pori, P. and Leskošek B. - SLO</i>	
Some Paths of Migration in Handball - Territory Characteristic	234
<i>Castro, J.; Sequeira, P. and Cruz, C. - POR</i>	
Goalkeeper - Specific Training for Youngsters. Characterization of the Importance and Structure in the Formation Process of Handball Goalkeeper	238
<i>Foretić, N.; Rogulj, N.; Srhoj, V.; Burger, A. and Rajković, K. - CRO</i>	
Differences in Situation Efficiency Parameters between Top Men and Women Handball Teams	243
<i>Gutiérrez Aguilar, Ó.; Ruiz Gómez, J.L. and Ramis Claver, J. - ESP</i>	
Using DEA to Assess the Efficiency of Handball Teams	248
<i>Hianik, J. - SVK</i>	
The Team Match Performance Indicators and their Evaluation in Handball	252
<i>Hulka, K. and Belka J. - CZE</i>	
Analysis of Evaluative Methods of the External Load on Players during a Match in Sport Games	257

<i>Ichimura, S.; Ogasawara, I.; Nakata, Y.; Inafuku, T.; Saito, S.; Todoroki, M.; Tamura, S.; Moriguchi, T. and Tanaka M. - JPN</i>	
Quantification of Shooting Play Position and Shooting Course from Pictorial Handball Match Statistics Report	261
<i>Laffaye, G. and Debanne T. - FRA</i>	
Prediction of Ball Velocity during Standing Throw and Gain of Velocity Obtained by Cross Over Step	267
<i>Laffaye, G. and Debanne T. - FRA</i>	
Training Programs Used by French Professional Coaches to Increase Ball Throwing Velocity of Elite Handball Players	273
<i>Lopes, A.; Sequeira, P.; Morgado, L.; Madeira, A.; Ildefonso, J.; Pires, B.; Cardoso, M. and Dinis J. - POR</i>	
Interaction in 3D Virtual Worlds: An Integrated Approach of Emerging Technologies in Handball	279
<i>Massuça L.M. - POR</i>	
Expertise Evaluation of Technical and Tactical Proficiency in Handball: Differences between Playing Status	282
<i>Molotans, A.; Līcis, R. and Žīdens J. - LAT</i>	
Goalkeepers' HRV Increase before Handball Competitions	287
<i>Platen, P. and Machado, C. - GER / ESP</i>	
Basic Endurance Performance is Highly Correlated to Mean Heart Rate in Female Top Level Handball Players	290
<i>Pori, M.; Justin, I.; Kajtna, T. and Pori P. - SLO</i>	
Which Motor Abilities Have the Highest Impact on Competitive Performance of Slovenian Handball Goalkeepers?	294
<i>Pori, P.; Skaza, V.; Bon, M.; Šibila, M. and Štirn I. - SLO</i>	
Effect of Learning on the Change of the Ball Velocity of the Set Shot in the Team Handball	299
<i>Pori, P.; Štirn, I.; Jeler, M.; Bon, M. and Šibila M. - SLO</i>	
The Influence of Feedback on the Change of the Ball Velocity of the Set Shot in the Team Handball	303
<i>Prisacaru, R. - ROU</i>	
Analysis of Tactics and Offensive Play Systems at the European Elite Teams in Order to Optimize the Attack of the Romanian “Top” Teams - Men’s Handball	308
<i>Rogulj, N.; Papić, V.; Foretić, N.; Srhoj, V. and Čavala, M. - CRO</i>	
Innovative Positioning of the Goalkeeper in Defence of Seven-Metre Penalty Shots in Handball	314
<i>Šibila, M.; Bon, M.; Mohorič, U. and Pori, P. - SLO</i>	
Differences in Certain Typical Performance Indicators at Five Consecutive Men's European Handball Championships Held in 2002, 2004, 2006, 2008 and 2010	319
<i>Skarbalius, A. - LTU</i>	
Monitoring Sport Performance in Handball	325
<i>Wagner, H.; Pfusterschmied, J.; von Duvillard, S.P. and Müller, E. - AUT</i>	
Performance and Kinematics of Various Throwing Techniques and Skill Levels in Team-Handball	331

Note:

All article references can be obtained directly from the authors.

Please find the corresponding e-mail address at the end of each article.

EDITORIAL

This first EHF Scientific Conference constitutes an important moment in the life of the European Handball Federation.

It must be seen as the natural outcome of the approach so far encouraged and implemented by the Methods Commission of the EHF. This approach, since the origin of the EHF, has consisted in pooling together the resources available in Europe in order to better understand, better serve and better promote handball.

The so called “Rinck Convention” probably was the first concrete step in this direction. Its aim was to harmonize and recognize the education and qualifications of handball coaches throughout the continent. Its major success has shown how right its promoters were.

The same objective is served by the technical documentation produced and published by the EHF, originally under the sole authority of the Methods Commission, now under the joint responsibility of the Commission and the recently established EHF Competence Academy and Network (CAN).

The foundation, two years ago, of the Union of University Handball Teachers must be considered as the next step in the upgrading of the quality of the service rendered to European handball. Taking advantage of the old association between handball and the world of education in Europe, it has brought together top academic experts in the field.

The celebration of the twentieth anniversary of the foundation of the European Handball Federation has supplied a perfect opportunity to bring together those who through their research work are likely to contribute to the development of our sport in Europe and beyond. The call for papers for this International Conference has met with tremendous success and it has been a very demanding task for the members of the scientific committee to select those to be presented on this occasion.

The coincidence in time of this conference with the decision made by the Executive Committee of the EHF to set up a European Anti Doping Unit sheds a bright light on our vision of the dialogue that must exist between science and sport. Let us take full advantage of academic research to promote our sport and those involved in it and never tolerate the artificial enhancement of performance.

I most sincerely thank those involved in the preparation of this event - especially the members of the international scientific committee - and I extend my best wishes to all participants. I have no doubt that the outcome of this first EHF Scientific Conference will prove most useful to all those who have made it their responsibility to look after the future of our game throughout Europe.

Dr. Frantisek Taborsky
Chairman of the Methods Commission of the European Handball Federation

PHENOMENON HANDBALL

Introductory Lecture at the EHF Scientific Conference "Science and Analytical Expertise in Handball"

Frantisek TABORSKY

Chairman of Method Commission of European Handball Federation
Charles University in Prague, Czech Republic

Summary

Using the term "Handball" we understand the sport game, which has been part of the Olympic Games programme since 1972. About seventy years before this date but nearly fifty years after, Handball has undergone unbelievably huge development. We are investigating the most important milestones of this way of progress, delineating substantial features of Handball, primarily from professional aspect, and trying to assign the most important tasks for the future.

Keywords: Handball, history, development, attractiveness, training, improvement measures

Introduction

The **Hand** and the **Ball** or the **Ball** and the **Hand**. Those two words characterized our sport in a lot of languages: Handball (GER, FRA, GBR and plenty more), Haandbold (DEN), Handboll (SWE), Handbola (LAT), Hondbold (FAR), Hendbollit (ALB), Hentbol (TUR), Ručnij Mjač or Gandbol (RUS), Andebol (POR), Kezilabda (HUN), Käsipallo (FIN), Chelburti (GEO)... or Balonmano (ESP), Palomano (ITA), Pilka Reczna (POL), and so on. In one language, a third term is even added **Game**: Handknattleiks (ISL), while in other languages the term describes the connection between the **Hand** and the **Throw**: Rukomet (SRB), Rokomet (SLO), or simply use only the word **Throw** as root: Házená (CZE), Hádzaná (SVK)...

A. Handball as Sport Game

Games with different balls controlled (managed) with the hands were performed already thousands of years ago. We can find evidences in all old civilizations. These games fulfilled not only the function of amusement but sometimes served as the medium of cults, rituals or religious purposes.

The **Sport** in its current form has its roots in the industrial society of 19th century. Organized cosmopolitan capitalistic communities, living by the rules of free competition, ascribed this characteristic more and more, also to different traditional kinetic pleasure activities. The modern sport has binding institutional and organizational structures on different territorial levels (local, national, continental, world). This is connected with the mutually accepted codification of the rules, statutes and regulations. Those obligatory graduates together with the performance levels (sport for all, competitive sport, top sport).

Sport Games are an unambiguous group of sport branches. A specific characteristic is the competitive activities between only *two rivals* (individuals, couples, teams) in *homogenous space and time* in which each party tries to demonstrate the superiority to the opponent by better manipulating the *common playing object* (ball, puck, flying disk...). In historical surveys, among other sport games (which are included in the programme of the Olympic Games), Handball appears to be the youngest but apparently fastest developing sport – see **Table 1**.

Table 1: Olympic Team Sport Games

Sport Game	Rules	World Fed.	N.F.	EURO Fed.	N.F.	OG M/W	WC M/W	C	EC M/W	C
Soccer	1848	1904 FIFA	204	1954 UEFA	55	1908 1996	1930 1991	4 4	1968 1984	4 2
Water Polo	1870	1908 FINA	179	1926 LEN	51	1900 2000	1973 1986	4 4	1927 1999	2 2
Hockey	1875	1924 FIH	118	1970 EHF	43	1908 1980	1971 1971	4 4	1970 1984	2 2
Ice Hockey	1878	1908 IIHF	70	---	41	1920 1998	1930 1990	1 1	---	-
Basketball	1891	1932 FIBA	213	1989 FIBA-E	53	1936 1976	1950 1953	4 4	1935 1938	2 2
Volleyball	1895	1947 FIVB	218	1964 CEV	55	1964 1964	1949 1952	4 4	1948 1949	2 2
Handball	1906	1946 IHF	182	1991 EHF	50 (+1)	1972 1976	1938 1957	2 2	1994 1994	2 2

(Taborsky 2011)

Legend:

N.F. = number of National Federations

OG, WC, EC = starting year

M = men

W = women

C = competition cycle in years

The end of 19th and beginning of 20th century were very favourable for the genesis of new games, mostly within schools activities. Some of those games gradually gained the sport character. We consider the first writing Rules: 1906 Haandbold (Denmark), 1908 Házená (Czechia) and 1919 Großfeld Handball (Germany) to be the starting point of Handball Sport Games (H.S.G.) These H.S.G. were practiced until the middle of 20th century exclusive in the European Continent. In the mutual competition among H.S.G., Haandbold (alias Handball or Handball Olympic) was finally the most successful. Nowadays we can note more variants of Handball under the umbrella of different international sport bodies – see **Table 2**. In this survey we do not mention the American and Irish handball (five) because of the substantially disparate manner of the game.

Table 2: Handball Sport Games

Handball Game	Some other Indication	World Umbrella Organization	Contemporary Diffusion	Other International Sport Bodies
HANDBALL	Team Handball Handball Olympic	IAAF (1926-1928) IAHF (1928-1939) IHF (1946- --)	Statutory 182 Countries	IOC, EOC, CIJM ... FISU, ISF, CISM, FISEC, IMGA ... CISS, SO
BEACH HANDBALL	Sandball	IHF (1996 - - -)	About 60 Countries	IWGA SAOC ...
MINI HANDBALL	---	IHF (1996 - - -)	Majority of "Handball" Countries	-----
WHEELCHAIR HANDBALL	---	IHF (2009 - - -)	About 10 Countries	-----
STREET HANDBALL	---	(2010 - - -)	Denmark	-----
HÁZENÁ	Czech Handball	FSFI (1921-1939) IAAF (1926 -1928)	Czechia	-----
FIELD HANDBALL	Großfeld Handball	IAAF (1926-1928) IAHF (1928-1939) IHF (1946-1977)	Germany	-----

(Taborsky 2011)

B. Development of Handball

Historically, in a relatively short period, Handball has demonstrated an extraordinary dynamic development. The most important increasing of interest in Handball has been noticed approximately during the last fifteen years. Among other positive influences, we can mention the more intensive activities of IHF and Continental Federations, the modification of Rules of the Game, the establishment of different programs for little developed Handball countries and the enlargement of top competitions – see **Table 3** and **Table 4**.

Table 3: Top Competitions from 1954 until 1971

	54	55	56	57	58	59	60	61	62	63	64	65	66	67	68	69	70	71
M	WC				WC			WC			WC			WC			WC	
W				WC					WC			WC			X			WC

(Taborsky 2011)

Table 4: Top Competitions from 2001 until 2012

Cat./Year	01	02	03	04	05	06	07	08	09	10	11	12
Men	WC	EC	WC	OG	WC	EC	WC	OG	WC	EC	WC	OG
				EC				EC				EC
Women	WC	EC	WC	OG	WC	EC	WC	OG	WC	EC	WC	OG
				EC				EC				EC
Men 21	WC		WC		WC		WC		WC		WC	
Men 20		EC		EC		EC		EC		EC		EC
Men 19	EC		EC		WC		WC		WC		WC	
Men 18						EC		EC		EC		EC
Women 20	WC		WC		WC			WC		WC		WC
Women 19		EC		EC			EC		EC		EC	
Women 18	EC		EC			WC		WC		WC		WC
Women 17					EC		EC		EC		EC	
Beach Men + Wom.	WG	EC		WC	WG	WC	EC	WC	WG	WC	EC	WC
				EC		EC						
Beach Youth											EC	EC

(Taborsky 2011)

Handball has now expanded worldwide, as a modern and attractive sport game – see also **Table 5**. Contemporary Handball is an indisputably significant sport, cultural, social and marketing phenomenon. Handball attracts huge number of people to both direct and indirect participation. Handball challenges the people to the admiration of sport idols and to self improvement. Between the forms of Sport for All (Mini Handball, Street Handball) to high performance Handball we can find a lot of levels of competitive forms. Under the millions of Handball players involved in performance Handball, only few talented athletes have the opportunity to train and compete in extraordinary favourable conditions.

Table 5: The Number of National Handball Federations in IHF

Year	EUR	AFR	ASI	PAN	OCE	Total
1946	12	-	-	-	-	12
1952	19	-	1	-	-	20
1954	19	-	1	2	-	22
1960	21	2	2	2	-	27
1970	25	13	6	5	-	49
1980	30	24	18	7	1	80
1990	31	37	22	14	1	105
1992	42	39	23	15	4	123
2001	46	44	32	19	5	146
2007	48	49	34	25	5	161
2009	48	50	37	28	5	168
2011	49	51	40	36	6	182
National Olympic Committees	49	53	44	41	17	204

(Taborsky 2011)

C. Popularization Measures

Those **differences** between low and top competitive sport are generally one of the **critical moments** in the future of sport development. As other development trends, we can first of all mention the continuously increasing **individualization**, **professional** attitude, influence of show **business** and the request for enjoyment and **excitement**. Out of traditional sport kinds arise new disciplines, which could be potentially unsafe and dangerous for Handball.

National Handball Federations exist formally in 182 countries. But handball only has really strong roots in approximately 30 or 40 of them. In a currently fast developed and competitive sport milieu and cultural and economical society, handball needs to fortify, firm and develop its own position continuously. How can we help in this struggle? What should be the priorities in those efforts? We believe that is necessary to direct our concentration to the following basic complex target: **The Popularization of Handball**.

The following are among the most important goals:

- The invigoration of Handball activities in **world leading states** with big population, such as China, India, USA and as well, also Great Britain, because of their enormous influence on a lot of Commonwealth countries.

- To include Handball in the **schools curriculums** on all education levels. An entire population passes through the school during the years. Most important, in this connection, are the universities which train and produce physical education teachers. The teachers with a strong Handball culture have better possibilities to influence positively and perennially. The programmes "Handball in Schools" of EHF and IHF or the foundation of Union of University Handball Teachers (UUHT) are good examples of already applied methods.

- To take care of the **attractiveness** of Handball on all performance level, and first and foremost on the important events, which are in the focus of the general public, sponsors, entertainment and mass media.

The attractiveness (appeal) of the Game depends on both the decisive bodies and the training conditions, as shown below. An important element of an attractive game is the **balance between the attack and defence**. We refer for example to the increase of the number of goals in the matches among the best top teams in the European Men and Women Championships. The Rules modification and the training measures have contributed greatly in the continuously increasing number of attacks and goals. But in the moment that the potential of this increase has approached a possible limit, we can observe a very clear effort of the teams to use more effective defence means and to re-establish the balance – see **Table 6** and **Table 7**.

Table 6: Score Statistic of Matches Among the Best Eight Teams – ECh Men

ECh	Number of Matches	Average of Score	Average of Goals Scored in 1 Match	Difference Winner-Loser	Difference in % (Winner = 100 %)
1994	18	25,8 : 21,7	47,5	4,1	15,9 %
1996	18	25,3 : 21,9	47,2	3,4	13,4 %
1998	18	26,9 : 22,1	49,0	4,8	17,8 %
2000	18	26,0 : 22,9	48,9	3,1	11,9 %
2002	18	27,6 : 23,6	51,2	4,0	14,5 %
2004	18	28,7 : 25,5	54,2	3,2	11,1 %
2006	17	31,8 : 28,7	60,5	3,1	9,7 %
2008	17	28,2 : 24,7	52,9	3,5	12,4 %
2010	17	28,8 : 25,1	53,9	3,7	12,8 %

Notice: The Match Results Without Extra Time

(Taborsky 2010)

Table 7: Score Statistic of Matches Among the Best Eight Teams – ECh Women

ECh	Number of Matches	Average of Score	Average of Goals Scored in 1 Match	Difference Winner-Loser	Difference in % (Winner = 100 %)
1994	18	24,2 : 20,4	44,6	3,8	15,7 %
1996	18	26,8 : 21,7	48,5	5,1	19,0 %
1998	18	28,8 : 20,9	49,7	7,9	27,4 %
2000	18	27,3 : 22,7	50,0	4,6	16,8 %
2002	18	27,5 : 22,9	50,4	4,6	16,7 %
2004	18	28,5 : 25,1	53,6	3,4	11,9 %
2006	17	29,2 : 23,1	52,3	6,1	20,9 %
2008	17	29,0 : 23,2	52,2	5,8	20,0 %
2010	17	26,1 : 20,2	46,3	5,9	22,6 %

Notice: The Match Results Without Extra Time

(Taborsky 2010)

D. Contribution of Training Measures in the Attractiveness of the Game

The most important contribution in the preservation and possible further enhancement of attractiveness of Handball can be provided through the **qualitative improvement of the training process**.

The information about the current training of the top teams and players is very limited, comminute and insufficient conclusive (exact). Therefore, I will try to mention the most problematic approaches on the basis of my empirical knowledge on **traditional state** by the majority of Czech Handball teams. We can find serious undesirable approaches already by younger (and junior) age categories. It is, for example, the case of premature strict specialization on Handball as well as on a fixed player's function. Versatile (all-round) kinetic foundation is insufficiently or inadequately developed. It seems that a lot of coaches believe that the best possible route to sporting success in young age groups is the accentuation and application of team tactic means, while individual practice and improvement is underestimated.

The majority of the following approaches can be prevalent amongst the Czech top teams:

- Often the largest volume of training is more opted and the qualitative aspect is neglected.
- A team (collective) form of training is entirely prevailing. The individual approach and motivating tasks of individual self-improvement are scarcely missed.
- In the condition component of training there is a disproportionate predominance of the means for developing aerobic endurance.
- In the technical component of training, not enough variable performance of playing activities is applied.
- In the tactical component the improvement of quick selective decision making is underdeveloped.
- The reinforcement of the players' mental capacity and positive team cohesion (resistance against stress, personal and team motivation, creativity, courage...) is strongly undervalued.
- The safeguarding of compensatory and prevention training means under lower economical, material and personal accessibility and poor erudition of trainer (coaches) is also insufficient.

In connection with the above mentioned empirical analysis, it is possible to pronounce a speculative premise about the **progressive methods** of the model (construction) of training in top Handball: **Playing drills** for individuals and small groups with **active opponents** and **"small" competitive games** shall dominate, and as far as possible with the emphasis on fast **decision making and efficiency** (prosperity) of the performance.

For the selection of training means the following are indicated:

- The concentration on the individual technical and tactical improvement of playing competence.
- The emphasis on the solution for the 1 against 1 situation (from attacking and defensive point of view).
- The exploitation of "open" attack combination (identical courses of the player's movement and free choice of passes and space of shooting).
- The application of different games with the elements of handball skills.
- The enforcement of "small" forms of handball (2 against 2, 3 against 2, 3 against 3, 4 against 3, 4 against 4 in reduced playing space).

The realization of the playing performance in the match and during the whole handball competition postulates specialized overcoming of specific motoric, psychical and social demands. The players (and the whole team) are confronted with complex loading situations

which are steadily and often unforeseeably changing. The loading of singular players during a particular match are different not only in aggregate but also in every single phase of the game. The accumulative playing load of each player in a match is influenced above all by the amount of direct participation time, through the playing function and the degree of opponent activities. This playing load brings together, in connection with the complexity of the problem, with numerous individual indicators and with incompatible methods of their measurement or assessment exceptional difficulties in comparison and the generalization of the results (in particular in top performance level with unique personalities). Every single conclusion is therefore consequently based not only on the findings of scientific investigations but also on commonly shared practical experiences.

It seems that the development of Handball is in some aspects faster than traditional trainings methods. Therefore, the task of research in this area, the search and the explanatory relations between competitive and training load and explicit formulation of inspirational stimulus for training practice shall be overriding.

In Conclusion

It will be also reasonable to support the science and professional researches on Handball in selected areas. This "Scientific Conference and the "Union of University Handball Teachers" are already important contributions to the majority of all the above mentioned strategic, methodical and professional goals.

UUHT was founded in November 2009 under the patronage of the European Handball Federation. **The Intentions of UUHT are:**

- To encourage contacts between university Handball lecturers and teachers.
- To facilitate the exchange of ideas and experience in the areas of teaching, scientific research and Handball promotion.
- To motivate teachers to submit publications and become Handball lecturers.
- To facilitate the cooperation of partners in sports science programmes.

At present, UUHT already has 33 members from 26 different universities and 16 countries from 2 continents. I would like to use this opportunity to thank so much all UUHT members for their active contribution and of course also for the respectable work of all the persons which are involved in the preparation of this Scientific Conference.

frantisektaborsky@seznam.cz

PERSONALITY TRAITS AS PREDICTORS OF PHYSICAL CAPACITIES DEVELOPMENT

Yessine ARFA

ISSEP Tunis, Tunisia

Summary:

1. Introduction
2. Method
3. Result
4. Discussion
5. Conclusion
6. References

Keywords: personality – physical capacities – handball

1. INTRODUCTION

Numerous studies demonstrate that a particular sport discipline has a particular appeal on people endowed with very particular personality features Kroll. W. (1967), Cooper L. (1969), Bouet M. (1969), Anton F. D. And Ghyslaire B. (1982), Bayer C. (1983). In other terms, some personality features determine the choice of the engagement in a particular sport. This choice is related to the specific characteristic of the sport in question, and determining somehow, the type of activity in which the player is engaged. This commitment, if it concerns the sporty speciality, does not prevent the possible existence of a preference related to the different aspects or the various components of the sporty speciality. Coaches easily notice that during a given exercise, all the players do not show the same extent of motivation. These preferences may have a relationship either with the type of activity: technical, physical or tactical or with the elaborated effort. This provides one of the possible explanations as far as training effect variations on players are concerned, even though these players actually undertake the same training type. Indeed, players belonging to the same team progress differently on both levels: the nature of the capacity and the amelioration degrees. Given the privilege granted to the physical capacity issued from the fact that any failure from this point of view affects the player's technical and the tactical and the psychological levels, it is very important to control the maximum parameters determining the nature and the degree of these abilities. Numerous surveys study biological parameters, or the concerning sport training techniques. But these surveys did not take into account the psychological determinants. This omission results out of the existing dichotomy between the different scientific branches having the sportsman as subject matter. In fact, the carving done for merely methodological consideration essentially aiming at a better study of the sportsman, cannot serve the sportsman's interest. It is imperative to bear in mind the necessity to consider the sportsman as a psychophysical unity evaluating in a specified social environment.

As far as this survey is concerned, the existence of a relationship between the personality features and the physical capacities is not excluded, and it is interesting to determine the nature of the relationship between personality traits and the development of different specific physical abilities.

In a former study, it has been demonstrated that the modifications of personality traits resulting out of competition sport practice effects Thill E. (1980), Tilleman K. (1965) Haris D. V. (1973), Hoiberg A. (1978) Ismail A. H. And Young R. J. (1978) Layman E. M. (1974, Folkins C. H. And Sime W. (1981) Martinek T. J. (1976) Collingwood T. R. (1972) Ogilvie B. (1979) Tattersfield C. R.(1982). Those modifications are partly explained by specific physical abilities development. This indicates the existence of a one way relationship between personality traits and physical abilities. But taking into account the role of personality traits in the player's orientation towards the choice of a sport discipline and in the determination of the player's preferences as far as the behaviour to adopt in diverse situations is concerned, does the player's personality profile influence the margins of his physical capacities ameliorations? In other terms, is the development of a given physical capacity tributary to the intensity of some personality traits? To provide an answer to this questioning we undertake this study based on the following hypothesis: Handball players' personality traits are linked to the nature and amplitude of the progression margins of the physical abilities specific to handball under the training effect.

2. METHOD

The sample:

Eighty seven subjects chosen at random make up the subject of this survey, this population is made up of 87 male subjects distributed into three groups accordingly to schedule Number 1. These subjects are handball players evolving in handball club in Tunis.

	14 - 15	16 - 17	18 - 19	total
males	29	29	29	87

Tools of measurement

The measure of personality traits and of the players' physical ability level is fulfilled through the use of the following tests:

The measurement of the personality traits: the Cattell's sixteen personal factors (16 PF)

Measurement of specific physical abilities:

Ruffier Dickson's test: adaptation of cardiovascular system to effort.

The speed test: In speed evaluation, we distinguish two aspects of speed:

The motion speed: time of ten rapid passes.

The basic running speed: time taken in 30 m race.

The strength of the arms: maximal number of arms flexions.

The Sargeant test: Vertical Jump = D2 – D1

The power of legs: $P = \{3.9 \times \text{weight} \times \{ \text{vertical jump} \}$

The approach method:

This study is achieved through the following procedure:

In s first step, we have established a list of clubs which are famous for the continuity of their activities and certain stability in their players and technical staff. Amongst the players, are chosen those who were willing to make part of the sample object of our research.

In a second step, the personality (Cattell's 16 PF) and the tests measuring the basic physical abilities (speed of motion and speed of move, Ruffier-Dickson test, the sergeant test and the test measuring the strength of the arms) and we have taken note of every player's weight which is to be used to calculate the p0wer of the legs.

After two years of handball practice their performances are retested through measuring the specific capacities already measured during the first test

The collected data is thus saved in a database of calculation under Microsoft Excel, then transferred to a database under SPSS 10 in order to proceed to statistical analysis.

Data analysis method:

Pretending that the handball player personality traits determine the nature and the width of the progression spans as far as his specific physical abilities are concerned, implies that :

On the one hand the existence of a significant correlation between the score of some personality traits and the value of the progression margin as far as the different physical capacities are concerned.

The existence of a significant regression (simple or multiple) in the value of the margin of progression of the specific physical abilities on the marks of the personality traits in concern. Consequently, we are led to use the step wise regression.

3. RESULTS

Significant step-wise regression exists between the initial standard scores of some personality traits and the variations of the performance relative to one or many physical capacities.

The following schedule involves recapitulation of the obtained results

	14 - 15 ans	16 - 17 ans	18 - 19 ans
Basic running speed	-.480 N - .357 L	-.459 N	-.393 H
Motion speed		.486 B - .469 I	
Ruffier-Dickson index	.680 B - .360 G	-.536 F - .381 Q4	.436 A
Vertical jump	-.383 Q1	-.422 Q1	
Higher limbs strength		-.422 L	
Lower limbs power	-.372 E + .349 N	-.547 L + .414 F	
<i>Cf 14. Result recapitulation .</i>			

TRAIT	Negative (low scores)	Positive (high scores)
A	Reserved, aloof, detached	Warm, friendly, attentive to other
B	Concrete, less reasoning ability	Abstract, more reasoning ability
E	Deferential, submissive, humble	Dominant, assertive, competitive
F	Serious, inhibited, somber	Lively, energetic, carefree
G	Expedient, unconventional	Rule-conscious, conventional
H	Shy, socially timid	Socially bold, venturesome, seeks attention
L	Trusting, accepting, easy-going	Vigilant, suspicious, skeptical
N	Forthright, naïve, self-disclosing	Private, discreet, shrewd
Q1	Traditional, resist change	Open to change, experimenting
Q4	Relaxed, placid, patient	Tense, driven, fast-paced

This schedule permit to notice what follows:

- The number of intervening factors in the determination of the margin span of the physical capacity variation differ from an age category to the other.
- The physical capacities holding the variation in relation with the personality traits vary according to age.
- The variations of a single physical capacity are determined by some personality traits that vary according to the age.

4. DISCUSSION

Even though the individual unity character needs no demonstration since the sportsman/sportswoman must be perceived as a psychophysical unity. And this making abstraction of the other sociocultural component which are not of least interest, is still important to approach the mechanism of process that consolidate or manage the stability of this structure. The result of the present research demonstrate a close relationship between the personality traits and physical capacities specific to handball game. It is revealed that the personality profile determines the sense and the width of the variation of these capacities, which are oriented as underlined by Schubert J. (1986) in a sense favorable to a better adaptation of the subject to the structure of the competition. This implies that the relationship may change according to the sport, because the variable "kind of sport" has initially stabilized, due to the choice to work solely on handball players. It has been made evident by the result of Clingmann J. M. and Hillard D. V.(1987) 's studies, that demonstrate the existence of a certain similarity between the personality traits of the subjects practicing the same sport which , according to them, can be used in prediction and physical components reinforcement.

Through the obtained results, it's possible to conclude that the dynamic of the relationship between personality traits and physical capacity evaluate according a circular causality. On one hand, the personality traits are at the origin of the individual's orientation toward the commitment in a given activity, and this according to Sadalla E. K. and Linder D. E. (1988) according to personality characteristics and the identity communicated by each type of sport in its quality of a system of symbols. Every person chooses the sport communicating the appropriate symbols to his desired social identity. This role attributed to personality is not only limited to the choice of sport of sport, but also it extends to the choice between the different components within the same sporting activity. This choice³ is performed according to the personality profile that represents the basic reference of the behavior and which make up according to Schurr K.T and all.(1977) the moderating variable or the characteristics facilitating, according to Missoum G. and Laforestrie K. (1983) these personality traits thus orient the individual towards a behavior corresponding to his own characteristics, implying either the birth of a motivation issued from the awareness of some physical deficiencies due to failures. These deficiencies compensated either by a different behavior (avoiding attitude) or by the birth of motivations and interest for the exercise fit to overcome these deficiencies and that result in a development of or several physical capacities. Or by the adaptation of a behavior of stable characteristics and seeking some physical capacities very particular to every behavior.

On the other hand, it has been demonstrated in a previous studies related to the effect of sport practice on personality traits, and namely the role of physical capacities development in the modification of personality traits, that the development of physical capacities explain the variation of personality traits . which seems to indicate that, along side with the maturation effect, the physical capacities thus developed react on the personality traits. Hence stems a modification of the profile and consequently of the behavior inherent to the game. Which in turn defines another sense to the physical capacities development. This occurs by the disappearance of some relations between traits and capacity giving way to the settlement ofr other relations marking the beginning of another cycle. This evolution evolves around the axis of conformity between personality and sporting discipline on one side Douthitt V. L.(1994) and tends toward a similarity between personality and attributes of the task as mentioned by Challadurai P. and Saleh S. D.(1979) on the other side.

It's possible to deduce that there is no typical champion profile nor a some sort of possibilities to shape the player's personality profile according our wishes, so that he achieves an optimal out

put. The personality owns its own mechanisms of development, and the practice of sport intervenes by a similar role to that of a catalyst in a chemical reaction. It allows thus a facilitation of the personality evolution providing it with the situational tools for a compatibility between the adequate thought and efficient action characteristic of the exceptional performance.

5. CONCLUSION

It become obvious that adapting coaching uniquely to the physiological and technical parameters - as is actually the case- is not enough anymore, but it has become essential, if we pretend to the coaching individualization to adapt the content of the formation to the psychological parameters by learning on date implemented by a psycho diagnostic before axing the physical development the capacities adequate to the player's behavior which emanate from his personality profile specific characteristics and to adapt the technical and the tactical formation to the cognitive structures suitable to every player.

yessinearfa@gmail.com

DO THE KINEMATIC OF THE THROWING ACTION IN HANDBALL INFLUENCE GOALKEEPER'S JUDGEMENT?

Benoit BIDEAU, Nicolas VIGNAIS, Richard KULPA, Cathy CRAIG, Paul DELAMARCHE

Movement, Sport and Health Science Laboratory, University Rennes 2, E.N.S. Cachan, France

Summary

The aim of this study is to evaluate the sources of visual information that a goalkeeper may use to anticipate where a ball is going. By using virtual reality, top national handball goalkeepers were presented with either the throwing action of an attacking player, the resulting ball trajectory or both of these conditions combined. Performance in the thrower only condition was significantly affected by the paucity of information concerning the direction of ball flight.

Keywords: Goalkeeper, anticipation skill, kinematic

Introduction

In a multitude of ball sports anticipating what an opponent is going to do next can give a significant competitive edge. Given the tight temporal constraints associated with different ball sports, a great deal of interest has been directed to the understanding of the potential visual information sources, notably body-based cues, that may be used by players to anticipate an opponent's next move (Abernethy, Wood & Parks, 1999). Results from several studies have shown that superior anticipatory ability is linked to level of expertise (Jackson, Warren & Abernethy, 2006; Williams, Davids, Burwitz & Williams, 1994), suggesting that the ability to perceive and respond appropriately to advance visual information is a discriminating factor for performance.

As mentioned previously, anticipation is very important in many sporting activities to gain a competitive advantage. This study will attempt to see what information is being used by goalkeepers to try and make important saves. Is the important information body-based and coming from the kinematics of the throwing action of the attacking player and/or is it the spatial-temporal unfolding of the ball's trajectory. A previous study in handball which used an eye tracking system suggested that the most important information is derived from the movement kinematics and orientation of body segments of the thrower (Deridder, 1985). This being said, the results in this study are confounded by the fact that the ball trajectory and the movement of the thrower could not be decoupled to see what influence each source had on the goalkeeper's judgment. Likewise a study by Craig & al focused uniquely on the effects of the changing spatial-temporal characteristics of the ball's flight path on goalkeepers' judgments ignoring the effect the movement kinematics of the player's kicking action might have had on goalkeepers' judgments (Craig, Berton, Rao, Fernandez & Bootsma, 2006). The aim of this present study is to therefore use virtual simulations of different throwing actions in handball to systematically decouple the effects of ball movement and player kinematics on goalkeepers' anticipatory spatial judgments about where a ball is going to go.

Methods

Subjects

15 top-level male handball goalkeepers (playing in first division and national level) gave their informed consent before participating in the experiment. Participants had a mean height of 1.81m (stdev=0.09m) and a mean hand length of 0.20m (stdev=0.01m). Mean participant age was 22.6 years (standard deviation 4.9 years) and all had normal vision.

Motion capture and animation of the thrower

In order to animate the virtual character and ball, real handball throwing actions had to be recorded. The VICON motion capture system was used to record kinematic data from different top-level handball players. Each player was equipped with 31 reflective markers placed on anatomical landmarks to precisely reconstruct 3D position and orientation of each limb segment with 6 markers being reserved for the ball. Each player was asked to throw the ball 12 meters from the goal aiming for different pre-specified target zones within the goal (no goalkeeper was present) (Figure 1). Captured throwing data were then incorporated into the animation module Manageable Kinematic Motion (a real-time animation programme) (Kulpa et al., 2005) to animate a virtual human character. The virtual ball movements were provided by another module which requires ball position and time at ball release along with the position in the goal and velocity.

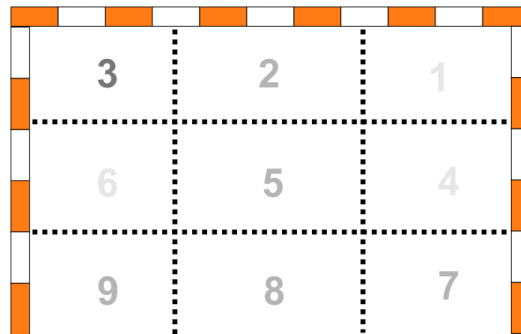

Figure 1: Target zones

Virtual Environment

A realistic handball stadium was created using VRML software. In order to enhance the feeling of presence, a real goal was placed where it was virtually represented in computer generated environment. Maintaining a realistic scale was deemed important in enhancing the feeling of 'presence' within the virtual environment. Three 82 synchronised video projectors (Barco 1208S) driven by a SGI 83 Onyx2 Infinite Reality (Silicon Graphics product) were used to project the 3D sports hall environment onto a large cylindrical screen (3.80m radius, 2.38m height and 135° field of vision). A set of glasses synchronised with the system enabled stereovision (60 Hz). The VICON motion capture system (12 cameras) was used to record goalkeeper movement and was coupled to the virtual reality display. As the two systems were linked and the goalkeeper's head was tracked, it was possible to change the goalkeeper's perspective in the virtual world in real time (delay <20ms).

Protocol

The experiment is divided into three parts. Part 1 involves the goal-keeper predicting the arrival position of the ball while seeing only the movement of the ball (ball alone - BA), Part 2 concerns the goal-keepers making predictions having access to only the kinematics of the thrower (thrower alone - TA), and Part 3 brings part 1 and 2 together, namely the player kinematics and ball movement (thrower with ball - TB) (see Figure 2).

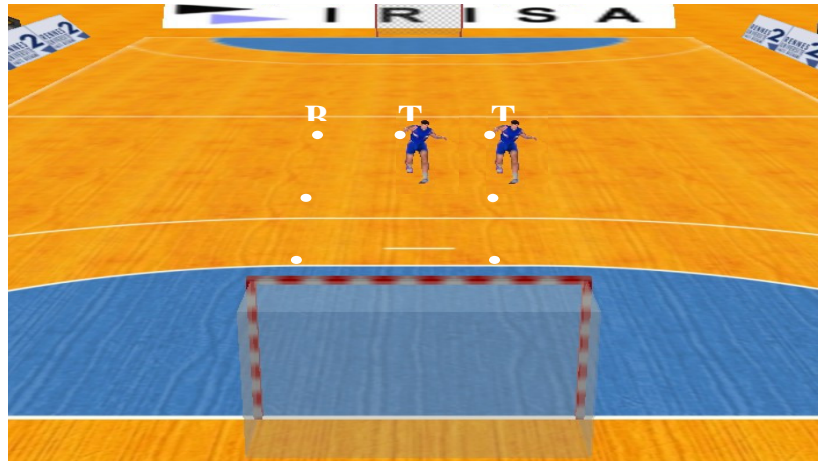

Figure 2: Different conditions

Each participant had a training period to allow them to become familiar with the environment and the task. During this time the participants saw 3 throws with the ball only (BA), 3 throws with the thrower only (TA) and 3 throws with the ball and the thrower (TB). As they would do in the real experiment, goalkeepers practised moving their hand to the position in the goal mouth where they thought the ball would arrive. The goalkeepers were equipped with 11 reflective markers. The markers were placed on the hands in such a way that the central position of the hand could be easily calculated. All trials in the training period were not included in the subsequent analysis.

Ball alone (BA)

A total of 9 different trajectories were presented in the ball only (BA). For each trajectory the initial position was 12 meters from the goal and the ball disappeared when it was 6 meters from the goal mouth (see figure 3). The ball velocities were similar for the nine trajectories ($19 \pm 0.2 \text{ m.s}^{-2}$) making ball flight time (0.32s) the same for all nine zones. The nine different ball trajectories corresponding to the nine zone arrival positions in the goal were repeated ten times and presented in a random order. In the ball alone (BA) condition, subjects saw only the ball trajectory without the movement of the thrower and were asked to observe the ball trajectory and predict where they thought the ball would end up in the goal by moving their hand to that position (see Figure 2). For each trial, the goalkeeper's final hand position was recorded and compared to the actual ball arrival position. The absolute deviation between these two distances was calculated.

Experiment thrower alone (TA)

The protocol in the second part of the experiment (TA) was the same as part 1 except for the visual stimulus presented to the participants. Unlike the ball only condition where only the ball from the time of ball release was visible, the participants in this condition saw the attacker perform the throwing action that would send the ball on a specific trajectory after ball release. To make the animation more realistic the virtual ball in the attacking player's hand was visible. The display was cut at ball release so that the goal-keeper did not see any part of the ball trajectory after the ball left the hand. This condition focused purely on the movement kinematics of the player that 'armed' the throw. In other words, the only visual information source that the goalkeepers could use to judge the future arrival position of the ball was the player's movement kinematics. As in the first part of the experiment goalkeepers predicted the future arrival position of the ball by moving their hand to where they thought the ball would end up in the goal mouth. Again there was a total of 90 throws (9 predefined arrival positions in each of the target zones, randomly presented 10 times).

Experiment thrower with ball (TB)

The third experimental condition combined the visual sources of information available in parts 1 and 2. In other words the participants saw both the throwing action of the attacking player and the 6m of the subsequent ball trajectory (see figure 3). Hand movements of where the goal-keeper thought the ball was going were recorded and compared to the position of where the ball would have gone had the simulation not been cut at 6 metres from the goal.

Results

% of successful responses

The first part of the analysis will look at how the type of visual information presented to the participants affected their perceptual judgments of where the ball would end up. A judgment was considered successful if the end-position of the hand fell within the zone where the ball would have landed had it continued along its trajectory.

The results show that the participants were least successful at predicting the correct zone when they were presented with thrower only information (mean=23.3%, stdev=4.3%). When presented with information pertaining only to the ball's flight path, participants were notably more successful (mean=78.4%, stdev=14.5%) at correctly placing their hand in the appropriate zone. The best performance was, however, unsurprisingly reserved for the thrower with the ball condition (mean=85.3%, stdev=13.8%).

This difference between the type of information presented and the responses given by the participants is also mirrored in the different zones of the goal (see Figure 3). All of the zones, except zone 1, show a decrease in the percentage of correct responses for the thrower only condition.

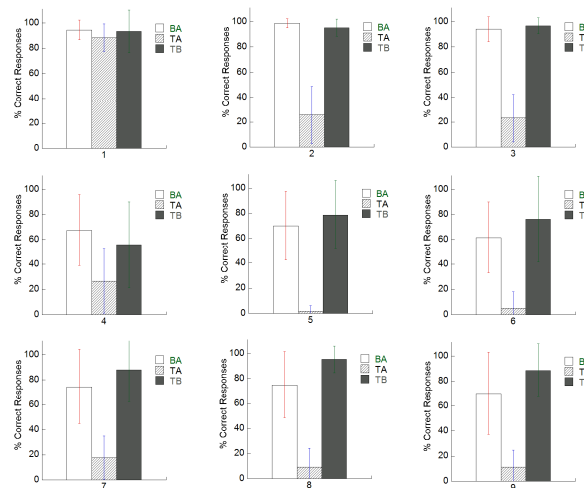

Figure 3: percentage of successful responses in different areas

A two-factor analysis of variance revealed a significant effect for both the type of information being presented to the goal-keepers ($F(2,378)=339.06$; $p<0.0001$) and for the zone in which the ball landed ($F(8,378)=20.117$; $p<0.00001$). A significant interaction for information source and zone was also found ($F(16, 378)=6.8602$, $p<0.00001$). Post-hoc tests (Tukey HSD) revealed that goal-keepers' judgments in the thrower only condition were significantly lower than the two other information source conditions in all of the zones except zone 1 (TA mean=88.3%; TB=93.3%; BA=94.4%). Overall the TB condition yielded a significantly higher percentage of

correct responses than the BA condition ($p=0.02$). In saying that zone 4 proved to be more difficult to judge in the TB condition (mean=55.8%) when compared to the BA condition (mean=67.4%) whereas zone 6 revealed a significantly lower percentage of correct responses in the BA condition (mean=61.6%) compared to the TB condition (mean=76.2%).

Radial Distance errors

The absolute radial distance error was calculated by subtracting the final position of the hand from the final arrival position of the ball. As the significantly greater percentage of failed responses for the thrower only condition (TA) translated into significantly higher positional errors the detailed spatial analysis presented in this section will focus on the ball (BA) and thrower/ball (TB) conditions only.

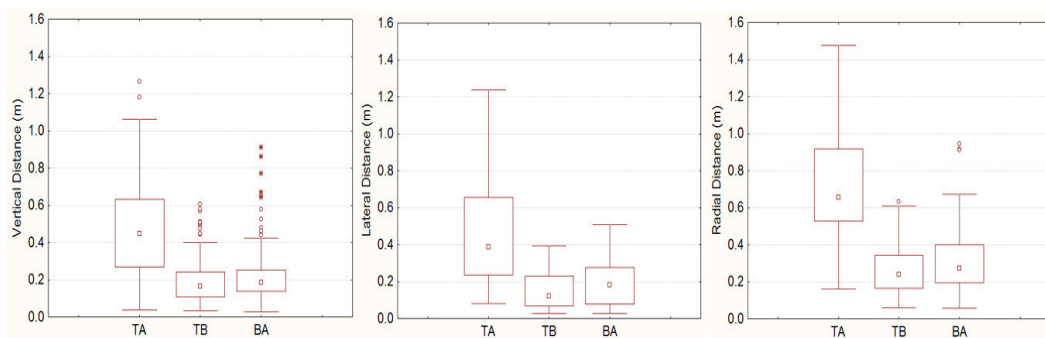

Figure 4: Radial errors

The radial distance for the TB condition (mean 0.265m, st.dev 0.11) was significantly lower than the BA condition (mean 0.312m, st-dev 0.11) ($F(1,252)=8.6113$, $p=0.004$). Significant differences in mean radial distances were also found for the different zones ($F(8,252)=7.8234$, $p<0.00001$) with zones 4 and 6 showing significantly greater radial errors compared to zones 1, 2, 3, 5 and 8. The significant interaction between arrival zone and type of information source ($F(8, 252)=1.9542$; $p=0.05$) suggests that the type of information source had a significant effect on radial distance errors in certain zones.

Comparison along the horizontal axis (BA vs TB):

The significant differences found for the radial distance were also found for the horizontal or lateral errors. The TB condition (mean=0.148m, stdev=0.06) were significantly lower when compared to the lateral errors recorded in the BA condition (mean=0.188, stdev=0.09) ($F(1,252)=17.435$, $p=0.00004$). Again the zones where the ball landed had a significant influence on the lateral errors ($F(8,252)=29.481$, $p<0.00001$), with zones 2, 5 and 8 yielding significantly lower lateral errors when compared to all the other zones (Tukey HSD, $p<0.05$). Again a significant interaction was found for arrival zone and information source ($F(8,252)=2.2636$, $p=0.02$).

Comparison along the vertical axis (BA vs TB):

When comparing the errors along the vertical axis no significant effects were found for the type of visual information made available to the goal-keepers (BA mean=0.198 or TB mean=0.224) ($p=0.132$). A significant effect was however found for arrival zone ($F(8, 252)=2.856$, $p=0.005$). This can be explained by the post-hoc analysis (Tukey HSD tests) which shows a consistent over-estimation of ball height in zone 4, compared to zones 1, 2 and 3 which yielded significantly lower vertical errors ($p<0.05$).

Discussion

The aim of this paper was to study the effect of different sources of visual information on a goalkeepers' judgment about where a ball will arrive in the goal mouth. By isolating the presentation of the thrower's movement kinematics and the trajectory of the ball we were able to look at the contribution of each of these information sources individually and together. The results show that the kinematics of the throwing action alone do not provide sufficient information for goal-keepers to accurately anticipate where the ball is going to end up. In some cases mean percentage of correct responses were as low as 2% (zone 5 - middle of the goal mouth). Only the kinematics of the throwing actions for balls landing in zone 1 were more accurately perceived by the goal-keepers. The significant percentage of erroneous responses in the throwing kinematics only condition unsurprisingly resulted in extremely large errors in final hand position. Although the ball only (BA) conditions were significantly more successful than the thrower alone condition, being able to see the movement kinematics that generate a resulting ball trajectory (TB condition) does seem to significantly improve performance when compared to the ball alone condition. The significant effect of zone on the percentage of correct responses suggests that the movement kinematics were being picked up and used appropriately in certain conditions. For example, the thrower only condition yielded a very high percentage of correct responses when the ball was landing in zone 1 (88.3% TA vs. 93.3% TB) which suggests that the goal-keeper can make an accurate anticipatory response by using the specific information being generated by that particular throwing action alone. Conversely, the movement kinematics necessary to throw the ball to land in zone 5 would appear to not generate any pertinent information that the goal-keeper can use to judge where the ball is going (2.0% TA vs. 78.6% TB).

To conclude the results presented in this study help clarify the role different sources of perceptual information may play when trying to intercept a ball. They reinforce the importance of being able to track at least part of the ball trajectory to correctly judge where the ball is going to end up.

benoit.bideau@univ-rennes2.fr

SOCIAL REPRESENTATIONS OF HANDBALL COACHES' ROLE

Diana-Luiza DUMITRIU¹

National School of Political Studies and Public Administration, Bucharest, Romania

Summary

The aim of the study is to analyze how coaches define their role and what impact these social representations might have on their everyday activity. Based on a multidimensional model of coaches' role, developed inside the dramaturgical theoretical framework, the focus of this qualitative approach is on the social construction of the representations upon the coaches' role on normative, referential and performative levels.

Keywords: *coaches' role, social representation, normative dimension, referential dimension, performative dimension*

Introduction

Nowadays sports means more than recreation, competition or healthier lifestyle as specific practices and social roles have been developed and even institutionalized inside this field. Moreover, we can speak about the crystallization of a phenomenon of *liquid boundaries* between sports and other social areas of life looking at the significant influence between them in terms of values, communication styles or behaviour models. One of these borrowed elements from the sports' field is the *coach figure* that was integrated and re-contextualized in other domains like business, education, politics or personal development trainings/activities. Based on this new position that sports managed to achieve in our social life and also on the autonomy and complexity of its structural and dynamic aspects, sports can be thus approached as a social field per se, in bourdieusian terms (Bourdieu, 1998). This is why it is important to understand and develop an emic perspective towards the dynamics of this field, starting with its actors' roles and their position inside the sports' micro-universe.

This study is focus on one of the sports' areas that has experienced a significant growth in popularity during the last decades, especially for the European public sphere, where feminine handball is probably one of the most dynamic feminine team sports in terms of media interest, finance investments, supporters' involvement and sports' show performance. Handball coaches play an important role in the dynamics of every team's evolution and, moreover, in the dynamics of handball itself, as one of the main sources of change and innovation in this sports' area and as one of the main public figures that had a powerful and active role in promoting this sport. However, the way a coach acts depends on his social representation upon his role inside this micro-universe of the handball field. Therefore, this study aims to highlight the relationship between the representational sphere and the corollary sphere of action. Based on a general framework of social representation (Moscovici, 1997), it can be said that the social actors' representations upon the social field of sports

¹ Beneficiary of the „Doctoral Scholarships for a Sustainable Society” project, co-financed by the European Union through the European Social Fund, Sectoral Operational Programme Human Resources and Development 2007-2013

is determinant in understanding their attitudes and behaviours inside this micro-universe. In addition, when speaking of competitive situations, there is an important distinction between the *objective competitive situation* and the *subjective competitive situation* (Weinberg & Gould, 2007), as two sides of the same coin of coping with the competitive experience. If the first one is defined by the existence of clear evaluation criteria known by at least one person who can evaluate the performance based on them (i.e. standards of performance, the level of performance in the past etc.), the second one refers to the way people perceive, accept and redefine the objective competitive situation. This last dimension of the sports' competitive situation will be the central component of the present study, outlining the way coaches' reflect upon their role in the professional context of handball activity.

Much research in the last years has focused on the coach-athlete dyad (Jowett, 2003; Jowett & Cokerill, 2003), exploring the nature of such relationships on different levels: cognitive, affective and behavioural one or trying to develop a model of effective coaching (Smoll & Smith, 1989; Horn, 2002) by identifying particular sets of elements that contribute to the profile of a successful coach. One of the elements that these approaches have in common is the emphasis they all put on the way athletes evaluate their coaches' behaviour, building up the coaches' image based mostly on this type of external evaluation. That is why the present study intends to offer an alternative approach, moving the focus of the analysis of coaches' role from "*the others*" perspective to the way coaches themselves define their role and the implication that this professional self-representation might have on the way coaches act in a competitive situation.

In discussing the concept of coaches' role inside the social field of sports, the theoretical perspective that this study will be based on is the framework of social dramaturgy, which, according to Stones, manages to integrate the double dimension of sports as both performance and competition (Birrell & Donnelly, 2004). Defined by Goffman (1961, p.82) as "the typical response of individuals in a particular position", the role of a person means continuously relating to a set of duties and social expectations that the role is associated with. Moreover, in addressing the theme of social roles, Goffman (1961) distinguish between complementary levels of analysis: the *normative model*, the *typical role* and the individual's *actual role performance*. As we move from a level to another, the importance of context and of the individual response to it and to the social expectation attached to the role become more significant. Therefore, the *actual role performance* is strongly dependent on the way the individual perceives and re-defines the particular situation he experiences. The dynamics of social construction of meanings and behaviours can be observed also inside the sports' field, the sports' actors being actively involved in sustaining a definition of the situation that they consider to be consistent with the image they have upon their role and the significances of these social roles they want to perform.

Besides these aspects regarding the criteria and the social expectations that the individual has to commit to, the most important component of one's performance is the *impression management* (Goffman, 1959/2003) that can be defined as the degree to which a person manage to control and direct the audience reaction. In front of a cosmopolite audience, the sportsman – athlete or coach - has to cope with, as Ingham noticed, "a fundamental dilemma, whether to conform to the expectations of his peers, the expectations of the management, or the expectations of the public, since each of these audiences may use different criteria for evaluation" (Birrell & Donnelly, 2004, p.57) and, on these grounds, he usually turns to the art of impression management.

Using the social dramaturgy conceptual props, this study can be seen as an exploratory approach of the social representation Romanian handball coaches have upon their role inside the social field of sports. How they define their role as coaches and, more important, why and what lies beneath that representation are the main research direction this study aims to focus on.

Methodology

For understanding the way coaches define their role inside the social field of sports and the mechanism of the representation behind this image, a qualitative study was chosen as research method as the proper approach for this exploratory stage of the research.

The 12 in-depth interviews were taken between November 2010 and March 2011 and the participants were all handball coaches (*which will be cited as “A, First League” and “A, Second League”*), half from the First and the other half from the Second League of the Romanian Feminine Championship. Upon consent to participate in the study, each participant was interviewed separately and the interviews lasted, on average, around fifty minutes.

Before discussing the results of the research it is important to mention some aspects regarding the general context and the implications it might have for the data analysis. Speaking of team sports in Romania, feminine handball is the one that achieved the highest performances in the last years in international competitions. Although we cannot speak of a comparative level of popularity as football has for Romanians - being considered the “national king sport”- it is important to outline the significant growth of interest that Romanian mass-media and sports’ lovers redirect towards handball competitions. This tendency can be correlated with the results that Romanian handball teams achieved in the last period at international level, but also to the evolution of the handball itself, which, due to the growth in speed and diversification of shots’ techniques, became a more attractive and spectacular sport show for the audience. One of the main implications of this evolution and of being more present in the public eye is a higher pressure on both coaches and athletes in order to improve or, at least, to keep the level of performances in accordance with the public expectations.

Results’ discussion

In discussing the results of the research there are three intercorrelated dimensions that have been explored and that can be used as the main levels of analysing the coaches own perspective upon their role inside the social field of sports: the *normative* one, the *referential* one and the *performative* one.

When analysing the normative aspects of coaches’ role and the main social representation regarding its content, there were three frames that came out in every subject’s discourse: the *results* frame, the *passion* frame and the *motivation* frame. However, the results frame distinguishes itself as the main component in defining and evaluating the coaches’ role and, moreover, as a sine qua non condition in the process of justifying their position inside the sports field. As one of the interviewed coaches noticed: “*Nowadays, no one in the Romanian handball or even from abroad judges a coach based on something else except for his results.*”(A6, First League). This dominant criterion in defining coaches’ role can be correlated with a more general orientation of handball coaches towards what theoreticians call *goal achievement* (Nicholls, 1989). Another aspect that coaches usually tend

to refer to when evaluating their activity is the “*hierarchy*” component, judging and planning their performance in terms of the position their team reached or is going to reach at the end of a competition season. From what position the team begins the performance journey under the coach’s guidance to what position the same coach manage to get the team at the end of a season is probably one of the most used exemplification of how coaches translate this results frame in a more tangible indicator. However, the pressure of results is greater as the team plays at a higher level of performance. Therefore, compared to the Second League, the coaches form the First League and, especially, the ones that play for a qualification in international competitions’ rounds have to cope with higher expectations from clubs’ management and fans and a shorter time horizon to meet them.

The *passion* frame can be better understood as part of a “personological” approach (Zlate, 2004) that stands for the existence of some sort of grace and calling for the role of a coach, a personal vocation that is sustained by a strong emotional involvement in performing this role on all three levels identified by Goffman (1961, p.94): attachment, engagement and embracement of the role. This is the component that makes the difference between occasional coaches and career coaches, becoming the fuel for all other elements of the coaches’ role puzzle. Moreover, for those coaches who have more than 20 years of practice what they first experienced as *harmonious passion*, being part of an integrated self-structure (Hodgins & Knee, 2002), became more like an *obsessive passion*, taking an overpowering space in the coaches’ identity (Lafrenière, Jowett, Vallerand & Carbonneau, 2010) and placing other aspects of their life under a shading cone. As one of the coaches admitted in speaking about the emotional involvement in his day to day activity as a coach: “*First of all, as a coach, you have to have a belief; ‘cause when you love handball and you have chosen this path, I think that you put all other things on a second place.*” (A, First League).

Although it was mentioned as an important component of coaches’ role, the motivational frame was very vaguely defined by coaches and mostly associated with the idea of mentioning a close and open relationship with all other actors inside the sports’ field, from athletes and fans, to sponsors, referees or other officials. However, the main aspect in discussing the motivational frame is its instrumental value. Starting with one coach’s observation that “*The coach should be the one who manages to motivate his athletes in order for them to believe in the victory, to believe in their potential and to use what they know to obtain a good result*” (A, Second League), it can be said that coaches use the motivational aspects as instruments in reaching a bigger objective: the goal achievement. As long as it helps this purpose, the motivational component of coaches’ role is considered to be an important one in coaches’ activity.

Before comparing the referential model with the normative one, it is necessary to make some observations regarding the way coaches chose their role models in coaching. In most cases we can speak about a “proximity model” and by proximity we mean the existence of a direct connection and a consistent interaction between the coaches and their role models. The concrete nature of this face to face interaction, the consistent time dimension of a collaboration relation makes this choice of proximity model easier and, somehow, predictable. That is why behind most of the referential models there is a history of apprenticeship, the role model playing the role of the maestro who had a significant contribution to the initiation of his apprentice in the coaching world. The gratitude dimension and the evaluation of the coaching talent are very hard to separate and, thus, most of coaches’ role models are, in fact, former coaches they worked with as athletes or sports science’ students. The only difference that is worth to be mentioned is that, while old coaches remain

devoted to this first proximity model, the young generation of coaches tend to make room for an alternative “hybrid model”, choosing referential elements from different coaches in order to build an ideal type of coach. Addressing this issue of puzzle-model, one of the coaches said that, based on his experience: “*There are no perfect coaches. You should take something from this coach, other thing from another coach as a model if you really want to achieve some results.*” (A, Second League). However, in terms of attributes associated with the referential coach model, we can find the same results’ frame as for the normative dimension. Thus, when speaking about the professional role model they have, coaches tend to focus on the track record and the most important results and sport trophies their role model manage to obtain in his coach career, reaffirming their dominant orientation towards goal achievement. The fact that “*results are the ones that make coaches to be good coaches*” (A, First League) means that in sports area, results are the social accepted criteria in evaluating a coach performance. The second aspect that was used by coaches to explain the difference between an usual coach and a “good coach”, in terms of referential potential, is an element that was not mentioned in the discussions about the normative dimension of the coaches’ role: the *pedagogic-formative role*. This formative component has two levels of manifestation: a self oriented one, as the coach is interested in developing his own abilities and improving his performance and a transitive one, which can be focuses either on preparing the new apprentices – coaches and initiating them in this direction, either on preparing great athletes and fostering them in order to achieve great performances. Although “*a coach who doesn’t achieve great results cannot be a great coach, can at the very most be a commonly coach*” (A, Second League), this formative dimension of the referential model can sometimes act as a substitute. This is true especially for coaches on lower level of performance (i.e. junior level, new formed teams), where the fact that they manage to discover and to foster a talented athlete, who then achieves great performance in his career, might be seen as an indicator for evaluating the performance of the coach himself.

On the performative dimension of coaches’ role one of the emergent aspects that could be identified apart from the components that had already been mentioned on the normative or the referential levels was the *strategist role*. In terms of the social dramaturgy approach, this strategist role of the coach can be compared with the one of the stage director who makes sure that his athletes prepare their role and perform it as they were told when the confrontation between teams is put on stage. Therefore, in relation to his athletes, the coach becomes not only the *role sender* (Eys, Schinke & Jeffery, 2007), but also the *strategist* who plans the tactical approach of a game and focuses on getting his athletes to follow the script they have prepared before a game and to perform their role in the team as well as they can.

Another aspect of the performative dimension of coaches’ role is the *dues ex machine* interventions, which refer to their punctual interventions during a game. These actions have an adaptive role, as the coach has to come with quick and effective solutions to the opponents’ tactics. Although the coach has prepared a strategy for the game, a complementary role is to be able to adapt the script based on the real evolution of the game and to find the winning responses to the opponent team’s actions. Even when the athletes “*like some toy-robots, are very well trained and you have rotated the key and let them play as you have trained them to do, you sometimes have to intervene when they bump against a chair and you have to put them on the right track in order for them to go in the direction they ought to*” (A, Second League). However, in practice, there always appears a gap between the normative, referential and the performative dimension of a coaches’ role, mainly explained by the limited responsibility and control that a coach has. The most common

explanation that coaches give for this is either based on the clear difference of value between teams, using a comparative frame of evaluating their own team versus the opponent one or based on an instrumental approach of their athletes as “working material”, which then becomes the main restraint or opportunity for team’s performance. So, much as “*you (as a coach) are enslaved by the results*” (A, *Second League*), at the same time, “*you should have a proper working material (athletes) in order to be able to reach great performance – you cannot have it other way!*” (A, *Second League*).

Conclusions

Using a multidimensional model of coaches’ role, this study provides a framework of analysing the social representation that coaches refer to when speaking about their activity and their role inside the social field of sports. The results show that there is a strong correspondence between the three dimensions of the coaches’ role - the normative, the referential and the performative one - and that is the dominant orientation of Romanian handball coaches towards goal achievement. Besides this result/outcome-component of coaches’ role, at the normative level of defining the coaches role, there are also the passion and the motivational frame that balance the coaches task orientation, although, in many cases, they have an instrumental value in the goal achievement process itself. What the referential level adds to the social representation of coaches’ role is the strong impact that the proximity model, usually correlated with an initial maestro-scholar relation from the beginning of coaches’ careers, has upon coaches’ self-evaluation. However, the performative dimension is the one that really outlines the main components of coaches’ role: results’ achievement, by introducing the strategist role of coaches and, furthermore, discussing the problem of limited responsibility that coaches have to cope with in their day to day activity. While the first one reflects coaches’ goal orientation, strengthening its place as the axis of coaches’ role representation, the second one acts as a rationalization strategy for the actual gap between desirable and actual performance. Due to its limitation as a explorative research, this study provides some valuable research insights for the social psychology of sports and, therefore, future studies should be oriented towards analysing this social representation dynamics of coaches’ role both in a more in-depth approach, as well as extending this type of approach in other sports’ domains or cultural areas.

dumitriu.diana.luiza@gmail.com

THE IMPORTANCE OF ROLES' DYNAMICS INSIDE A TEAM

Diana-Luiza DUMITRIU¹

National School of Political Studies and Public Administration, Bucharest, Romania

Summary: Focusing on the roles' dynamics inside the group, the main aim of this study is to analyze the relationship between the social dimension and the task dimension of handball teams. This case study revealed the presence of a contamination effect between the social and the task evaluation of the members' positions inside the team and the fact that the level of intra-group competition has a strong impact on how members' positions in the team tend to be evaluated.

Keywords: *roles' dynamics, contamination effect, intra-group competition, social dimension, task dimension*

Introduction

The first step in analyzing the evolution of a team is to understand its dynamics as a social unit. Even if a team undertakes the characteristics of any other social group, thus being defined by common norms, values and a reciprocal influence between its members, as Lussier & Achua noticed, „although a team is a group, not every group is a team” (apud Preda, 2006, p.64). The main aspects that make the difference are the common tasks and responsibility, as well as the complementarity of its members' abilities, which describe the type of interaction and interdependency relationships between the team's members.

Analysing the dynamics of a working group, Chantal Leclerc identified three main dimensions: the instrumental one, the relational one and the contextual one (apud Neculau, 2007, p.44). While the first dimension refers to task achievement and the aspects involved by this type of activity, the relational one focuses on what many find as the “soft” component of a group's activity: the social dynamics, in terms of the nature and the evolution of the relationships between members. Furthermore, the contextual dimension adds the concrete framework of the group, as it exists and performs in a specific environment that influences its activity. Therefore, while the first two dimensions tend to be interested in the endogenous forces of the group, the last one takes into consideration also the exogenous factors that contribute to the group's dynamics.

If we narrow down the focus upon sports teams, besides the aspects that have already been mentioned, the importance of the competitive framework should be added as a main factor in explaining teams' dynamics. Moreover, even the design of the particular sports' area in which the team performs has a great impact upon its dynamics. Thus, based on this sport design dependency, Terry Orlick identified three dominant categories of behaviour responses: competitive, individual or cooperative one (apud Weinberg & Gould, 2007, p.117). The matrix of combinations corresponding to what types of means and ends orientations are being involved influences the nature and intensity of the team's structure and processes. That is why, in analysing a handball team, the cooperative

¹ *Beneficiary of the „Doctoral Scholarships for a Sustainable Society” project, co-financed by the European Union through the European Social Fund, Sectoral Operational Programme Human Resources and Development 2007-2013*

means-competitive ends design acts as a very important contextual factor in understanding the team's dynamics.

As any other group structure, a sports team is defined by a particular set of roles, based on which its members interact. On a formal level, these roles can be easily associated with the players' positions (i.e. goalkeeper, left wing, pivot, right back, playmaker etc.), which determine the game relationships inside the team. Moreover, these formal roles have a significant importance for the team's performance and require a clear delimitation of each athlete's sphere of action and responsibility associated to his contribution to the overall goal achievement of the team as a unit. That is why, when speaking about the formal roles inside the team the focus is mainly on the task dimension of the team's dynamics. Nevertheless, besides this formal role structure of a team, there is also an informal dimension of the team's dynamics generated by the social nature of the relationships between its members. Although different, the formal and the informal levels of roles' dynamics inside the team can be defined in terms of complementarity and one's evolution cannot be completely independent of the other and, more important, of the team's performance. That explains why there has been a great interest in phenomena like sports teams' cohesion (Carron, 1982; Mudrack, 1989; Carron et al., 2004; Carron, Shapcott & Burke, 2007) which involves both task and social dimensions of the group's dynamics and their impact on team's performance in terms of goal achievement process.

In speaking about the roles' dynamics inside a team, this study provides a framework of analysis based on an interactional approach. If most of the studies tend to focus on the facts and the processes inside the teams, outlining the players' roles "in action", the present one is interested in the backstage mechanism of representations upon these roles - that is on how players themselves perceive the role dynamics inside the team. The main premises that symbolic interactionism (Blumer, 1969) rests on affirm that individuals act towards things or people on the basis of the meanings they ascribe to them and, moreover, these meanings themselves arise out of the social interaction that a person has with others. Re-contextualizing this continuous process of significances' social negotiation to the sports field, it can be said that the way an athlete acts inside a team depends on how he interprets and internalises his role and his teammates' roles inside the team. Furthermore, the *actual role performance* (Goffman, 1961) of an athlete is based on the way he perceives and re-defines the particular situation he experiences and thus his performance is subject to a permanent social construction. As earlier studies have already showed in discussing the problems raised by *role acceptance* or *role clarity* (Eys, Schinke & Jeffery, 2007), besides the descriptive level of analysing the role structure of a team or the discussion upon its impact on team's performance, it is important to understand the athletes' perceptions of the roles' dynamics inside the team.

Based on this relationship between athletes' sphere of social representations and their sphere of action, this study intends to provide both a research framework for the analysis of roles' dynamics inside a team, as well as a more concrete instrument that coaches or other members of the team's staff may be able to use for a better understanding of the team's evolution. In trying to identify the relation between the perceptual and the factual role configuration of the team, the study will explore both the social and the task dimension of roles' dynamics inside the team.

Methodology

The research perspective upon the roles' dynamics inside sports teams is based on a case study on a professional handball team from the Second League of the Romanian Feminine Championship. Moreover, the methodological design of the study rests on a mix-method approach that combines a sociometric analysis of group members' relationships, on both factual and perceptual level, with the observation method applied during training and competition contexts and in-depth interviews with the team's coach. The present research has a longitudinal dimension, as the study was conducted over a period of two competition seasons (2008-2009 and 2009-2010), in two waves. If we were to make a brief remark regarding the contextual aspects of the team's evolution, for a better understanding of the roles' dynamics inside the team, it is important to say that these were also the first two years of this team's existence. So, using Tuckman's model of small-group development (Tuckman & Jensen, 1977) and adding to it the specificity of sports teams - that is the cyclicality of teams' membership from a competition season to another - the case study includes the storming and norming stages of the team in its first year of existence and competition activity, but also the first stages from its second competition year. As for the sociometric test, in order to be able to analyze the relationship between the perceptual and the factual dimensions of the roles' dynamics, the design of the research instrument was based on a two axis crossing (Figure 1): the perceptual-factual one and the attraction-rejection one.

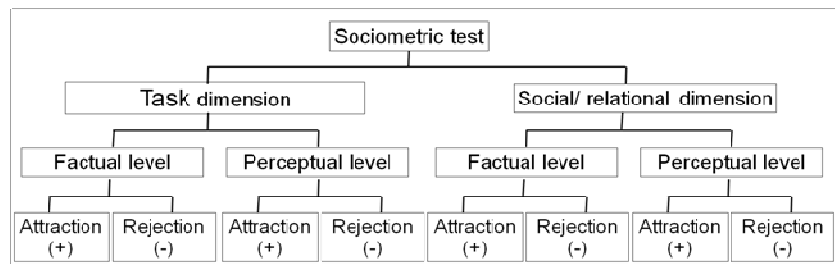

Figure 1. Design of the sociometric test

Results and discussion

There are three main dimensions that we can refer to in discussing the results of the research: the evaluation of the role's distribution on task and social level, the visibility of roles inside the team and the degree of athletes' accuracy in evaluating their own position inside the team. This balance between the two complementary perspectives: the manner in which each athlete perceives that he is seen by his colleagues and the way he himself evaluates other members' positions inside the team is a re-contextualised form of the principles behind the classical looking glass self model (Cooley, 1902). So, what this study is focus on is the comparison between alternative perceptions of team's members on their own role and on the roles of their teammates, trying to identify convergent and divergent perspectives which, in fact, constitute the real basis of the roles' dynamics inside the team as a social construct per se.

On a descriptive level of analysis, the results of the sociometric test showed a quite different situation between the task and the social dimension in terms of the team's structure of roles on these criteria. While the task roles' structure is a centralised one, on both the positive (attraction), as well as the negative (rejection) levels of professional recognition, the team's sociogram reveals a high level of fragmentation and the lack of a relational leader inside the team. As the team's coach pointed out when discussing the climate inside the team: *"What this team lacks of is the presence of a hen that could gather its chickens around it."* However, these micro-groups that emerge on the social dimension of the team's dynamics are strongly correlated with the previous team's

structures that the athletes came from. Thus, based on the existence of previous common experiences as teammates in other teams, the tendency is to build the social structure of the new team around these pre-existing ones.

Besides this macro-level of team's structure on the task and social dimension, there is the micro-level of dyads of choices that outlines another interesting psychosocial phenomenon of "contamination". This contamination effect between the social preferences and the task evaluations of the team's members seems to be stronger on the perceptual level, where the likes and dislikes perceived by a player tend to be extrapolated on the task performance evaluation too and, so, 1 of 2 choices from the social and task dimensions' registers mirror each other (Table 1). The lower degree of choices reflection on the positive register on the factual level of choices (1 out of 4) can be explained by the fact that on the positive level of the task dimension there are two undeniable task leaders that concentrate most of their teammates choices. This situation is based on their known competition track record as their performances and experience is far better than the rest of their teammates and leaves little room for subjective evaluation. We can thus conclude that, if there are not clear performance indicators to sustain a significant difference of professional value between the members of a team, a contamination effect between the social and the task evaluation of the roles' dynamics inside the team could arise.

Correlation between attraction and rejection registers		FACTUAL LEVEL			PERCEPTUAL LEVEL			INTEGRATED RESULTS
		Attraction (+)	Rejection (-)	Factual total	Attraction (+)	Rejection (-)	Perceptual total	Sum factual & perceptual
Wave 1: 2008-2009	Team index	0.28	0.44	0.36	0.67	0.51	0.59	0.47
Wave 2: 2009-2010	Team index	0.25	0.46	0.35	0.71	0.42	0.56	0.46

Table 1. Contamination effect index (the ratio between how many mentions on social dimension are the same as the ones on task dimension and the maximum number of identical choices that could have been made on both dimensions)

Another important aspect regarding the relation between the task and the social preferences is related to the degree of internal competition between athletes playing the same position/role. Hence, when the differences of value between athletes that have the same playing position in the team (i.e. 2 or 3 left wings) are smaller, there is a tendency of athletes to underestimate their teammates' positions on the task dimension and to place them on the rejection list on the social one.

In discussing the visibility of an athlete inside the team, there are two main observations to be made, based on the visibility index (as the ratio between the maximum number of possible choices and the total number of actual mentions of a person on all dimensions and levels): the players with the highest visibility inside the team are also the ones with the highest rejection level on task or social dimension and newcomers in the team (as the results of the second research wave show) tend to have a lower visibility rate inside the team. Therefore, it could be said that the rejection orientation towards a person and the time dimension of a player's participation in the team's activity have a strong influence in determining one's visibility inside the team.

The most relevant indicator for the analysis of the relation between the factual and the perceptual level of roles' dynamics is probably the accuracy level of players' evaluation of their own position inside the team. In exploring this aspect, the accuracy index was built on the comparison of the athlete's perception regarding his teammates' evaluations of his position and the actual choices of the team's members. As the results showed (Table 2), the accuracy level of knowing their own

position inside the team is greatest on the attraction level of the social dimension. One of the factors that contribute to this symmetry of relational dyads is the explicit recognition of relational preferences between athletes, as it is well known that people tend to easily express and admit their positive attitudes and feeling towards others compared with the more implicit dimension of the negative ones.

Accuracy of self-position inside the team		TASK DIMENSION			SOCIAL DIMENSION			INTEGRATED RESULTS
		Attraction (+)	Rejection (-)	Task total	Attraction (+)	Rejection (-)	Social total	Sum task & social
Wave 1: 2008-2009	Team index	0.26	0.19	0.23	0.67	0.21	0.44	0.33
Wave 2: 2009-2010	Team index	0.33	0.23	0.28	0.56	0.21	0.39	0.33

Table 2. Accuracy index of self-position inside the team

Looking at the evolution of the accuracy levels from a season to another, the increase in accuracy on the task dimension can be explained by the increase in knowledge about the other team's members and the crystallization of a team history and role structure. Athletes had time to demonstrate and evaluate each other's abilities and contributions to the team's performance in a comparative way and that is why their evaluations tend to be more convergent. On the other hand, the decrease in accuracy on the attraction level of the social dimension may be related to the weakening of the pre-team relational structures between the athletes. If during the first research wave the mentions on the social dimension were made based on a minimum common activity of the athletes as a team, which made the choices be oriented mainly to the teammates that shared a previous team experience, in the second research wave the relationships developed inside the team diminished the predictability of "we have known each other before" principle applied in the first wave.

As it was mentioned earlier, besides these aspects regarding the analysis of the team on the two axes of task and social, factual and perceptual roles' dynamics, a second aim of this case study was to develop a concrete framework that coaches themselves could use for a better understanding of their teams' evolution. One of the outcomes of this process was the development of a graphic representation of athletes' position inside the team that could offer a synthetic image for the coach. What we call the "individual map of choices" (Figure 2) allows a visual representation of the relation between the factual and perceptual aspects of a player position inside the team, on both positive and negative levels of task and social dimensions.

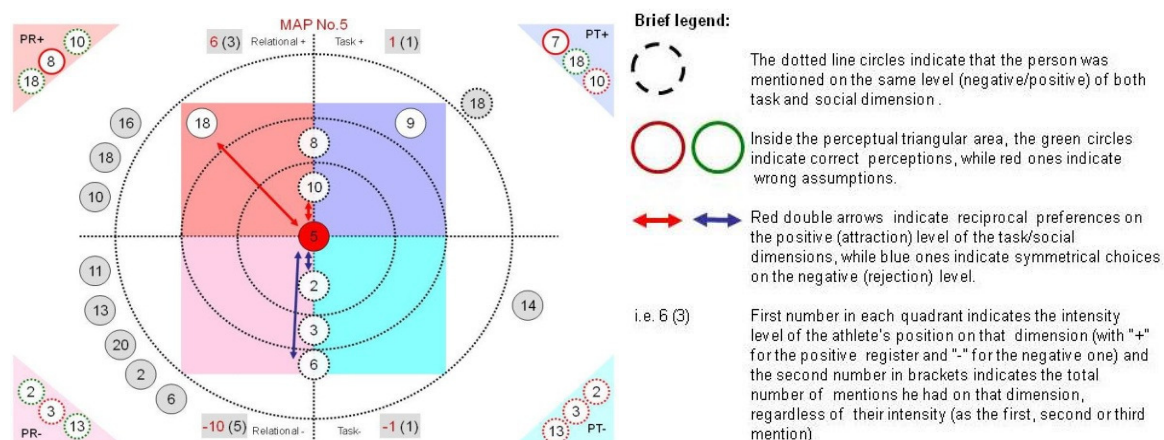

Figure 2. An example of an individual map of choices for player no. 5

Conclusions

Focusing on the roles' dynamics inside a new formed professional handball team, this case study shows that there is a strong correlation between the factual and the perceptual levels of task and social group's dimensions. The results revealed the emergence of a contamination effect between the social evaluation of the members' positions inside the team and the task evaluation of their positions at the group level, based on an extrapolation process of the relational preferences to the task level. Another key finding is that, if the differences between athletes' individual performance are not significant - in terms of objective indicators of performance, the level of intra-group competition has a direct impact on how other group members' positions in the team are evaluated. Moreover, in comparing the manner in which each athlete perceives that he is seen by his colleagues and the way he actually is evaluated by his teammates, it can be said that the accuracy level of perception is higher on the positive (attraction) dimension and gradually increases from a competition season to another as the common experience of the team's members and their familiarity with each other increases in time. Understanding the cycle of a team's evolution from the perspective of its roles' dynamics is an important resource for a coach who is trying to cope with the permanent balance between individual and group performance. Thus, identifying the key-roles inside a team and their dynamics can facilitate both communication and task achievement for the group's members, which strengthens the need and value of developing this research area through other similar studies.

dumitriu.diana.luiza@gmail.com

DECISION MAKING IN PORTUGUESE HANDBALL REFEREES

Maria Luísa ESTRIGA^{1,2}, Jorge Manuel COSTA¹, Alexandre MELO¹
and Paula FAZENDEIRO BATISTA^{1,2}

¹ Faculty of Sport, University of Porto, Portugal; ² Centre for Research, Education, Innovation and Intervention in Sport, University of Porto, Portugal I

SUMMARY

The main purpose of this work was to quantify the accuracy of the Portuguese elite Handball referees. We used a multicamera based process to assess, by means of an expert, the referees' decisions in fifteen matches. We verified that ¼ of all decisions were errors and of these about ½ were serious errors. The main difficulties were found when ruling the 7-meter penalties and the 2-min. suspensions, with a strong bias towards the major teams.

Keywords: *handball, referees, judging*

INTRODUCTION

Handball refereeing is commonly focused by the media, the coaches and others, as their decisions may affect the outcome of matches and competitions. However the published knowledge about the referee's performance is quite modest. The published studies about refereeing in handball deal mostly with transgressive behaviors and stereotypes about gender (Souchon et al. 2004, Souchon et al. 2010) and the referees' use of heuristics (Souchon et al. 2009; Souchon et al. 2010). Studies in other sports (e.g., soccer, basketball and ice hockey) have investigated the influence of other factors affecting the referees' judgment: home advantage (Nevill et al., 2002), aggressive reputation of a team (Jones et al., 2002), the game moment (Trudel et al., 2000), situational factors and personal style (Souchon et al. 2004). Novill et al., (2002) assessed the influence of crowd noise and years of experience on qualified referees' decisions and concluded that the noise played an important influence on referees' judgment - mostly a home advantage (Nevill and Holder, 1999; Courneya and Carron, 1992).

Since the 1976 Olympic Games (Montreal) several changes to the book of rules have been introduced for promoting spectacularity and a less violent and rough behavior.

Certainly, the rules changes and their interpretation by players, coaches and referees have been decisive in the actual trends of the game. Today, the idea of a high-speed game has gained consistency, as frequently approached by several handball experts in coach's education programs all over the world. Concomitantly to this new interpretation of the game, with faster attacks, a symmetrically deeper and faster defense answers and a more intensive usage of the *big space*, we may ask if there is a need for more skilled and prepared referees. Does this increased velocity of play represent an increased challenge to the decision making process of referees?

METHODS

Sample

Fifteen matches of the Portuguese Men First National Championship (2009-2010 sport season) were analyzed. Eighteen elite Portuguese male handball referees were involved in this study. Because this study was conducted in close collaboration with the Portuguese Handball Federation the referees were blind about the study until the results were first presented. Confidentiality and anonymity was guaranteed to all participants involved, including referees and clubs.

Procedures

Match recording

Each match was recorded by three HD cameras (1920x1080x24@25fps) from elevated positions. Two were at the top of the playing court and on opposing sides to provide a detailed close view

of the action near the goal and a third one was located at middle court to get a wide-angle view of court. A preliminary study revealed that several cameras were necessary to avoid occlusion scenes and to provide different perspectives of the same action in order to make clear what really did happen.

All obtained videos from different cameras were time synchronized. This allowed the investigators to easily view different perspectives of the same match scene.

Observed referees judgment

The fifteen matches from the Portuguese Men First National Championship were first analyzed by two of the investigators who produced a shorter video, including all the “official” fouls and all potentially missing fouls. Afterwards, an expert (retired international handball referee and official educator of international referees) reviewed all the selected incidents.

For every detected incident (foul), we also registered the time of the match, the score difference, the faulty and/or victim players, the phase of game (attack, defense, defense or attack transitions) and field positions (the game space was split in 14 sub-spaces).

DEVELOPMENT (RESULTS AND DISCUSSION)

Results: in the 15 games a total of 2570 incidents were identified, 160 interventions were considered incorrect and 252 were identified as an oversight of intervention. Per game we found an average of 171 incidents when the goal validation was included and 117 when the goals were not included as incidents. In figure 1 is showed that the most frequent faults in handball are the free-throw from the 9-meter line, 2-min of suspension and 7-meter throwing, which is a consequence of the contact and invasion nature of the game.

Globally 77% of the decisions were considered accurate. As a comparison, in football the published results (Button et al. 2006) are around 64%. However our results show a concentration of incorrect judgments - including incorrectly sanctioned and unsanctioned but existing fouls – in the application of 2 min of suspension, free-throw (9-meter line), 7-m throwing, to many steps, throw-off and advantage provision (see figure 1). This result provides clues to improve the referees education and training. Unfortunately we were unable to find any other studies to compare our results with. These results also reinforces that referees must pay particular attention to the disciplinary faults in order to control the aggressiveness and to protect the physical integrity of players.

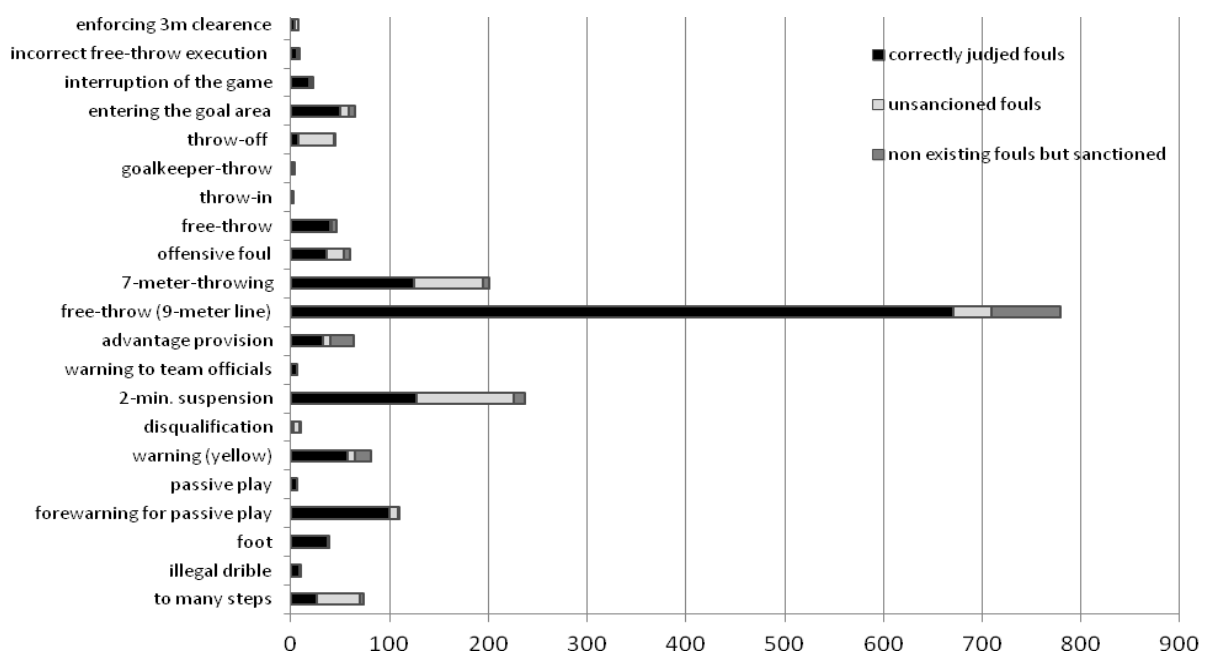

Figure 1. Number of incidents per type and judgment

A sub-categorization considering only major mistakes was computed. We defined a “major mistake” as an error involving a 7-meter throw, a 2-min. suspension, a disqualification or an illegal goal score. Figure 2 presents the number of incidents and mistakes during a match. There is a smooth tendency for an increase of mistakes around the first 10 min. and the last 5 min of the match.

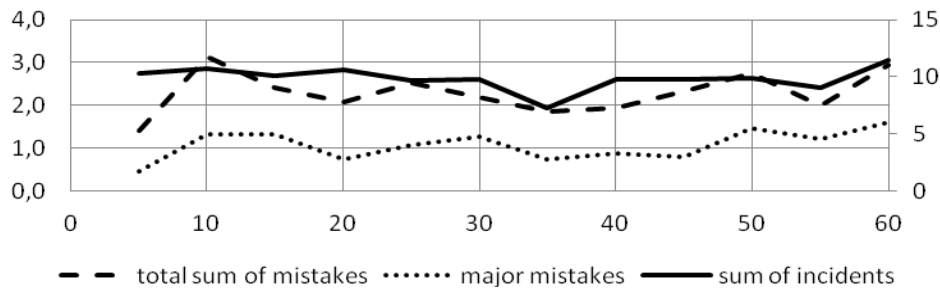

Figure 2. Number of incidents and referees' mistakes during a match

This data also reveal an increased number of incidents at the end of the matches, particularly the 2-min and the 7-meter ones (figure3). But when we analyzed the type of errors in the end of matches the 2-min of suspension appeared as the most frequent error. Other studies, in other sports, have already documented the beginning and the end of the game as the moment when transgressive contacts happens (Trudel et al., 2000).

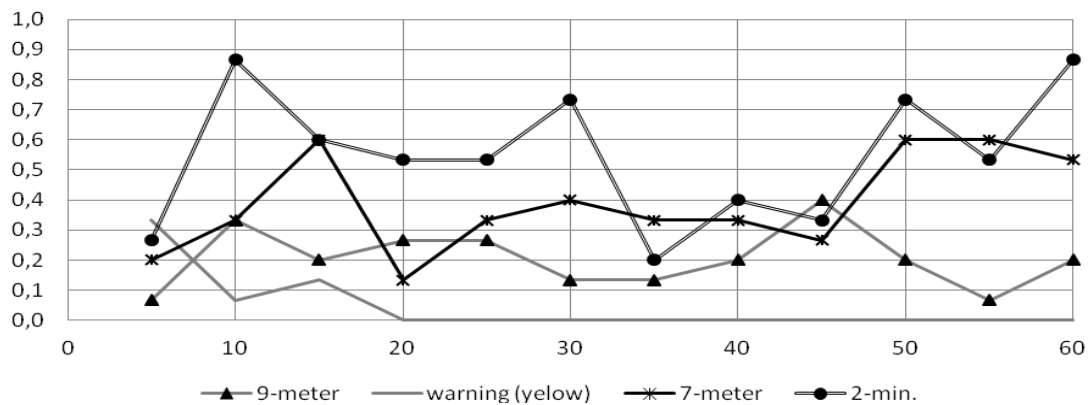

Figure 3. Incidents (9-meter fault, yellow card, 7-meter and 2-min suspension) throughout a match time

The number of errors tended to increase when the score was unbalanced by 5 goals of difference or more (score differences much higher than 10 have no statistical quality). Maybe the referees are less concentrated in situations with large score differences.

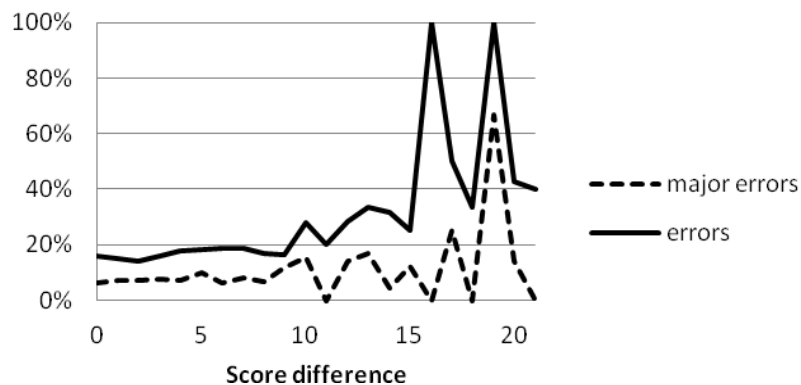

Figure 4. Relation between the score difference and the number of errors

From these 15 matches, two were draws, seven were wins by the home team and 4 by the visitant team. These results are in agreement with the expected home advantage factor described by the literature (Nevill & Holder, 1999). In the table 1 are presented the distribution of errors per match and relative to the home team.

Computing which team was “favored” in each referee error and testing for the randomness of this with a binomial distribution, we obtained a value of 33% of matches were the “favoring” was not random ($p < 5\%$) i.e. one team was much more “favored” than the other. In 20% of the cases, the distribution was not random and the number of errors favoring the winning team is in excess of the final goal difference between the two teams. So, in 20% of the cases the winning team is possibly a direct result of the not-random “favoring” of the referees.

We are analyzing the causes of these non-random errors. The best clue, statistically, is not the home team but the best teams. The best teams are more favored than the more modest teams (B, D and F in table 1)

Table 1. Percentage of errors per match.

Match	Score difference	Incidents (excluding scores)	Errors	Major errors	Home favoring errors	Major home favoring errors
A-B	5	82	16%	7%	18%*	33%
A-C	3	108	10%	5%	64%	60%
D-C	2	97	23%	10%	63%	60%
D-E	0	125	42%	11%	49%	50%
D-I	10	124	23%	12%	72%*	80%*
I-F	0	117	25%	16%	46%	42%
F-E	3	153	24%	15%	71%*	65%
F-D	0	104	15%	9%	65%	89%*
F-B	5	119	19%	16%	55%	53%
D-G	6	132	32%	11%	78%*	67%
C-H	21	133	26%	13%	59%	47%
F-C	3	129	22%	15%	63%	53%
F-J	3	124	25%	14%	76%*	71%
D-I	6	109	23%	9%	57%	60%
G-D	1	98	21%	14%	30%	14%*
<i>mean</i>	3	117	24%	12%	60%	56%

*statistically significant

We also analyzed the distribution of incidents relative to the circumstances of the game and roles of players. The majority of incidents occurred during the defense phase (78% in the organized defense and 9% in the defense transitions), with only 11% in the organized offensive phase or the offensive transition (2%). The incidents typically were occurred in the middle positions (including pivot, middle and middle back left and right positions), with a very high number of incidents between the 6 and 9-meter lines (59%) and the 9-meter line and 12 meter distance from the goal (21%). Comparatively, the distribution of major errors committed by the referees, revealed an increased percentage of mistakenly judgments in the middle positions, between the 6 and 9-meters line (66%) and the left wing position (16% errors and 8% of faults). A very high percentage of faults in the front and near the goal are easily understandable, because it is in its self a more favorable position to score a goal, so the fight for this space with or without the ball is maximum.

CONCLUSIONS

Globally 24% of the referees' decisions were considered inaccurate. The results revealed a concentration of incorrect judgments - including incorrectly sanctioned and unsanctioned but existing fouls – in the application of 2 min of suspension, free-throw (9-meter line), 7-m throwing, to many steps, throw-off and advantage provision. The results provide important clues to improve the referees education and training. The number of errors tended to increase when the score was unbalanced (more than 5 goals of difference) and in the beginning and in the end of the matches. However these findings need to be further investigated.

We obtained a value of 33% of matches were the “favoring” was not random ($p < 5\%$) i.e. one team was much more “favored” than the other.

In conclusion we counted one error for every four decisions made. Of those errors $\frac{1}{2}$ were considered serious errors (13 errors per match or 11% of all rulings). A better preparation, guidance and evaluations are recommended in order to improve the referee's intervention.

ACKNOWLEDGMENT

We want to publically express our gratitude to the Portuguese Handball Federation who has supported this work in many ways (not only financially), and particularly to Prof. Pedro Sequeira and Mr. António Goulão.

lestriga@fade.up.pt

MUSCLE STRENGTH AND ACL INJURY IN PORTUGUESE FEMALE HANDBALL PLAYERS

Maria Luísa ESTRIGA^{1,2}, João MARQUES DE CARVALHO³, João BERNANDEZ⁴
and Leandro MASSADA^{1,2}

¹Faculty of Sport, University of Porto, Portugal; ²Centre for Research, Education, Innovation and Intervention in Sport, University of Porto, Portugal I, ³Faculty of Engineering, University of Porto; ⁴Faculty of Medicine, University of Porto

SUMMARY

Purposes: to investigate the relation between the maturation, muscle strength and ACL injury risk. Total sample: 496 Portuguese female handball players. We measured some isokinetic muscular force indicators and vertical jump capacity in the various subgroups and accounted for all previous and subsequent ACL injuries. Conclusions: our results reinforce the importance of the knee flexor musculature in the ACL rupture prevention.

INTRODUCTION

The ACL rupture is the most worrying injury in the Portuguese female handball population, affecting mostly young players (Estriga 2008). The ACL incidence among Portuguese male handball players is unknown, although the risk of ACL rupture was found, in other populations, to be 5 times higher in female handball players than in male players (Myklebust, Maehlum et al. 1998).

It has been suggested that the anatomic and physiological changes occurring during female puberty increase the functional joint instability (Quatman, Ford et al. 2006), which would be related to an increased risk of ACL ruptures. However, limited research has examined the effect of maturation and female hormonal *milieu* on the neuromuscular system, particularly in young female athletes. Curiously, this is the critical period for the development of the player's technical abilities and tactical decision-making in handball. These improved competences (physical, technical and tactical) by themselves, make better protected players. Unfortunately the opposition is also becoming stronger and more dynamic, placing even greater demands on the players. As the musculature can have a protective affect on the knee (Solomonow and Krogsgaard 2001) through the active knee stabilization mechanism, it is interesting to know the strength profile of our handball population, from an early age until the senior category.

Study purposes: (a) to examine the influence of maturation, OC status, previous knee injuries and handball exposure in jump performance, (b) to characterize any muscular force adaptations over the players' handball career, including asymmetries and consequent risk of ACL injuries; and (c) to investigate a possible epidemiological correlation between lower limb isokinetic strength and previous or subsequent ACL injuries.

METHODS

Participants

Four hundred and ninety-six female handball players from 38 clubs, from the category of infants until seniors (adults), were included in this study. OC usage of 3 ± 3 years. All players reported to be using low-dose combination pills (containing synthetic estrogens and progestins).

Procedures

Experimental design

Participants underwent a sequence of anthropometric, and jumps measurements as well as filling a questionnaire about injuries and menstrual cycle characteristics. A sub-group of players (100 female players 19±4 years old) were asked to come to the Sports Faculty 3 months after the beginning of the sport season, for both a functional evaluation (including Isokinetic Strength Measurements) and a clinical examination performed by an orthopaedic surgeon. At the same time these players were also participating in a prospective injury study.

Vertical jumps

A contact platform was used to assess the height jumped (h). This was calculated from flight time (t_f) and gravity acceleration (g) as $h = g \cdot t_f^2 / 8$ (m) (Bosco, Tihanyi et al. 1996). The testing session included a sequence of three attempts of vertical squat jumps (SJ) and three attempts of vertical counter movement jumps (CMJ). Three to five measurements were taken for each jump test.

Isokinetic Strength Measurements

The isokinetic torque-angle curves were obtained with a standard dynamometer (Biodex-System 2, NY, USA) at an angular speed of 90° s⁻¹.

DEVELOPMENT (RESULTS AND DISCUSSION)

Jump performance

On average, there was an 8% (14 mm) increase on the CMJ result in comparison with the SJ. The two jump tests were highly correlated ($r^2=0.75$).

Table 1 shows the average results for each jump test regarding the age category and playing category.

Table 1 Jump height by playing categories

Age category	Playing category	N	SJ (mm)		CMJ (mm)	
			Average (mm)	Standard deviation	Average (mm)	Standard deviation
Infants		85	205.6	35.9	219.7	41.4
	<i>Infants</i>	68	198.6	34.0	212.6	40.9
	<i>Infants/starters</i>	17	233.5	29.8	247.9	30.5
Starters		128	230.5	46.6	248.3	44.3
	<i>Starters</i>	83	220.1	45.6	238.1	43.8
	<i>Starters/juveniles</i>	45	249.6	42.6	267.2	39.2
Juvenile		107	217.1	38.4	234.1	43.3
	<i>Juveniles</i>	63	209.5	40.3	227.3	46.7
	<i>Juveniles/Juniors</i>	44	227.9	33.0	243.7	36.4
Juniors		60	219.6	42.7	242.5	40.6
	<i>Juniors</i>	34	207.8	37.4	232.3	34.8
	<i>Juniors/Seniors</i>	26	235.0	45.0	255.9	44.4
Seniors		92	238.4	42.5	260.8	48.6
Total		472	223.1	43.0	241.6	45.9

Even though jump height tests are quite popular among handball coaches, we could only find a couple of published studies on this subject. In a small sample of young Spanish female handball players (N=24; age=14.2 ± 0.4 years) on average the results measured with a force plate were 20.2 ± 0.01 cm for the SJ and 22.0 ± 0.01 cm for the CMJ, representing an increase of 8.2% (Vicente-Rodriguez, Dorado et al. 2004). Their results are quite similar to ours, just slightly lower in the categories of starters and juveniles, in both jumps.

The menarche status is a well-established index of female physical maturation, which occurs during puberty, and triggers the beginning of the female hormonal secretion cycle. The average

results for both jump tests were higher in players already menstruating¹: higher 9.6 mm in the SJ ($p>0.1$) and higher 16.5 mm in the CMJ ($p<0.008$). Obviously, an age effect can't be ignored. Figure 1 is a plot of the jump performance over age. What we can see is that even if there are changes coinciding specifically with menarche (average 12 years) they are no bigger than other changes occurring along the full range of ages. There are strong reasons to suspect of a significant performance change during puberty. It is just that there is not a dramatic change in this indicator in our population.

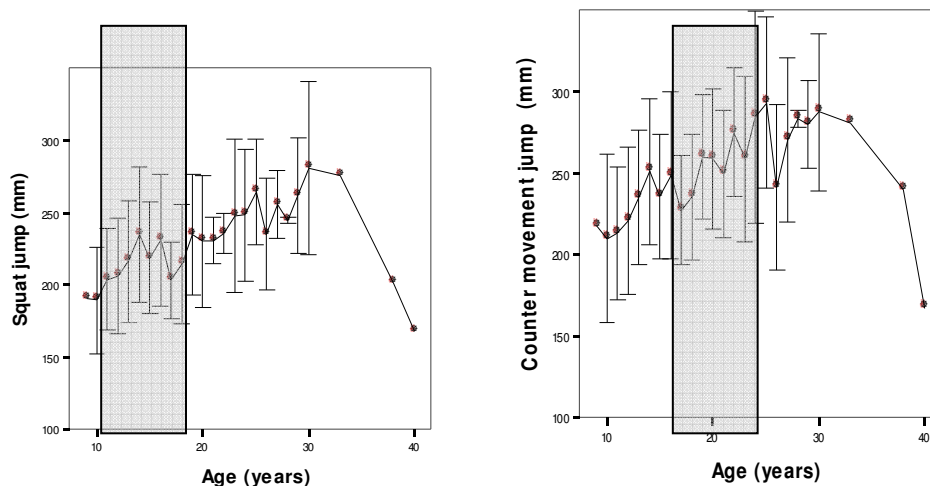

Figure 1. Age distribution of jump performance (with window of menarche occurrence)

There are similar studies on these subjects, with dissimilar conclusions. Quatman *et.al.* (2006) found that male athletes showed increased vertical jump height with maturation along with reduced landing forces, while no similar adaptations were found in female athletes. However, both sexes showed a reduction in lower limb loading rates with maturation. Similarly, other authors have reported sex differences in jump height during maturation, with an increased jump height performance in boys and unchanged jump height performance in girls (Temfemo, Hugues *et al.* 2008). These authors concluded that the observed differences were due to a larger increase in leg length and lean body mass in boys than in girls, particularly from 14 years onwards.

Analysing the dependence on OC usage, we observed an increase of $\cong 8\%$ in the CMJ height in comparison with the SJ irrespective of OC usage. The mean differences between the OC users and non-OC users (2.0 mm in the SJ and 2.5 mm in the CMJ) were not statistically significant ($p>0.7$). However, OC users ($\mu = 64 \pm 9$ kg) were heavier than the non-OC users ($\mu = 61 \pm 10$ kg) ($p=0.01$). No significant differences were found in BMI ($p>0.1$) or % fat mass ($p>0.3$) between the OCs and non-OCs groups.

Several questions have been raised about OCs-induced weight gain, metabolic changes and their potential negative effect on physical performance. Rickenlund *et al.* (2004) found significant increases in weight and body fat content only in oligo-/amenorrheic by contrast to eumenorrheic athletes after 10 months of OCs treatment, with an insignificant impact on several physical performance indicators (including endurance and strength tests).

Comparing the mean jump heights between players with previous knee injuries and those without knee injuries, respecting laterality, there were significant differences in the SJ between players with healthy knees (221mm) and players with previous injuries in the non-dominant knee

¹ For this analysis we excluded all senior players (see first paragraph of page 176)

(243mm) – ANOVA: $p < 0.04$; HSD: $p < 0.022$. These differences are not statistically significant in the case of the CMJ (marginally, $p > 0.057$).

Isokinetic Strength of Hamstrings/Quadriceps

The sub-sample of players which participate in this study was subdivided into 3 groups: those with no previous history of ACL injuries (N=91), those with previous or chronic ACL injury (N=9) and those that in the following year suffered an ACL rupture (N=4).

Players with no previous history of ACL injury

After normalization to body weight the isokinetic evaluation at 90°/s revealed an (H:Q)_{conc} ratio of 45%±7% what is regarded by some as a low value and an ACL risk factor (Hewett, Myer et al. 2001). This ratio is statistically different ($p < 3.3\%$, N=82) between nondominant and dominant limbs (46% vs 45%) but this asymmetry is insignificant from an epidemiological and biomechanical viewpoint (Hewett, Myer et al. 2001). Other nondominant-dominant asymmetries statistically significant ($p < 5\%$) but also biomechanically inconsequential (Hewett, Myer et al. 2001) regard the extension peak torque and total flexion work.

For both dominant and nondominant limbs the (H:Q)_{conc} ratio seem to increase along with the playing categories, particularly until the Juniors category, but in any of the cases the differences were not statistically significant ($p > 5\%$). The Juniors presented the highest (H:Q)_{conc} ratio (48%±6%), particularly at the nondominant lower limb. Curiously the majority of the ACL ruptures studied in our work (Estriga 2008) occurred in the nondominant limb and in players up to 19 years old (Juniors or below).

Analysing the quantities by playing position for the specialization categories (Juniors and Seniors) one can see a remarkable difference between the goalkeepers and the field players. However the sub-sample is very inhomogeneous with just 4 goalkeepers (of the 11 tested), 8 pivots and 39 field players. We have found no statistically significant differences between any groups, but possibly the very small sample size for the goalkeepers affected the conclusions. However, a laterality analysis (paired samples) found asymmetric H:Q values for the field players ($p < 4.8\%$) and asymmetric extensors peak torque for the pivots ($p < 3.5\%$). This only makes us hypothesize the existence of a connection between the specific load of playing and the muscular adaptation. In any case, further work on this should be done with larger sample sizes and with more specific tests.

Players with previous history of ACL injury reconstruction

This small (N=9) group was composed of 8 Senior players (1 goalkeeper and 7 field players) and one Junior player (field player). They had sustained an ACL rupture and subsequent reconstructive surgery, on average, 4 years ago (1 to 7 years). There is no significant injured – non-injured leg asymmetry in this population in any of the isokinetically measured parameters. However there is a significant difference ($p < 1.7\%$) in the extension peak torque between the injured leg of this group (203 mm) and the nondominant leg of the general population (group with no previous ACL injuries) in the same age category (231 mm). The knee where reconstructive surgery was performed shows, 4 years later on average, about 10% reduction of the extension peak torque, but no reduction in the extension work (there is even a non significant increase). The current practice of using segments of the patellar ligament for the ACL reconstruction may, or may not, have some role on this. In any case it seems fair to say that, in our population, players who underwent an ACL reconstruction and returned to handball practice, did not recover completely even after an average of 4 years post surgery. This is in agreement

with other published reports (Lund-Hanssen, Gannon et al. 1996; Osteras, Augestad et al. 1998; Jarvela, Kannus et al. 2002).

Players with an ACL injury in the following year

This very small group (N=4) refers to subjects that had been evaluated with their ACLs intact and had suffered an injury a few months later. The very small sample size makes us avoid any kind of global or statistical description of this subgroup. There is no apparent common trend in these 4 subjects except that all suffered the injuries during a match. We have injuries in both the knee with the highest H:Q_{conc} ratio (61.5%) and the knee with the lowest H:Q_{conc} ratio (37.9%).

ACL injury risk factors

Aggregating data from all subgroups enabled a logistic regression, to identify the most promising isokinetic risk factors. In the database we have 4 ACL injuries in the right knee and 7 in the left one among 97 valid cases (a 4% to 6% incidence in about a year). This difference, although not significant (Wilcoxon $p>0.7$) makes analysis to the right leg data statistically harder.

The logistic regression is the classical tool for accessing risk. Unfortunately its application to our data, on the predictive power of isokinetic measures for the ACL injury risk, is insignificant for both the right ($p>0.72$) and left limbs ($p>0.32$).

However a simple odds ratio analysis shows that an improvement of a single N.m of knee flexor torque improves the chances of *not having* an ACL injury by 1.27, on average. Unfortunately, the 95% confidence interval still contains unity.

A more flexible tool is the neural network (figure 2). We are aware of the low statistical quality of the subjacent data, however the introduction of other statistical tools is of great importance when data is valuable (hard to obtain) and refractive to the *classical* methods. A simple one layer, two node, linear network² explains $r^2=62.6\%$ of all variation.

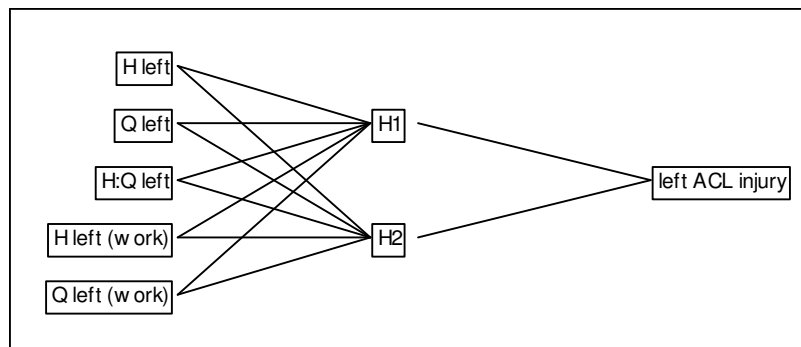

Figure 2. Neural network

With this model we predict every ACL injury in our database and obtain only 4 *false-positives*, in 97 cases, with a cut-off point of 0.218.

CONCLUSIONS

In this population we showed that lower limb force, measured by the jump capacity, have insignificant progresses from 11 to 16 years old (between 13% and 17%). This all points to a deficit in sportive selection and conditional training.

² Overfit penalty: 0.001; 50 tours; 10^{-5} convergence criterium

These players are subjected to the competitive loads (even international) but have to carry the added weight and body fat content while showing lower conditional capacity *e.g.* to avoid risk situations, to dynamically stabilize the knee, *etc.* They are exposed to a high dynamic risk of knee injury.

We have characterized the Portuguese female handball population on some of its isokinetic parameters. We have established some slight associations between the handball career evolution, some isokinetic quantities and the ACL injury risk.

Our results, although based on weak data, contradict the H:Q risk hypothesis. According to our model, the hamstrings peak torque alone is a better indicator of ACL injury risk.

We concluded that the ACL injury (even with surgical reconstruction) may take a long time to recover, at least the isokinetic muscle function parameters.

Practical implications

To our understanding, this type of knowledge is important also for coaches, who are responsible and interested in promoting the safety and physical integrity of the players. Handball coaches, well informed about the injury problems, are in a better position to adopt efforts for preventing injuries, and to make educated decisions about reintegration - in the training process and competition - of clinically recovered players, and therefore decreasing the likelihood of reinjury in players.

lestriga@fade.up.pt

HANDBALL TEACHING AT SCHOOL – A PRE-SERVICE TEACHING EXPERIENCE BASED ON THE SPORT EDUCATION MODEL

António Luís Tulha Duarte FERREIRA¹, Paula FAZENDEIRO BATISTA^{1,2}
and Maria Luísa ESTRIGA^{1,2}

¹Faculty of Sport, University of Porto, Portugal; Centre for Research, Education, Innovation and Intervention in Sport, University of Porto, Portugal

SUMMARY

This study was an action-research concerning the usage of the Sport Education Model in handball teaching at school, whose goal is to educate students to be knowledgeable and enthusiastic in sports (Siedentop, 1987). The study was done during the Practicum (Master degree in Physical Education), in the school year 2009-10. The results revealed significant increase in students' learning capability in various domains (social, cognitive and motor).

Keywords: *Handball, Physical Education, Sport Education Model, Pre-service teacher.*

INTRODUCTION

The teaching of Physical Education requires new formulations and adaptations to fight visible disinterest among students and teachers (Graça, 2008). In the last few years alternative models for game-play teaching have been developed. These models use modified forms of the game, give more emphasis to the tactical component and by sharing responsibility they promote autonomy and cooperation among students. These factors exceed the simple motor development and are an essential part of constructivist learning.

The Sport Education Model developed by Siedentop (1987), whose goal is to educate students to be knowledgeable and enthusiastic in sports, is a good example of this. The purpose of this Model is to develop a positive behavior in students, encouraging responsibility, cooperation, autonomy and commitment, allowing for young people to actively construct their own way of learning. The Model integrates formal sport characteristics. The common didactic unit is converted into a sport season, where students participate in teams and take different roles that characterize the formal competition. Students are responsible by affiliation, record keeping, organization of the festivity and culminating event and many other tasks where a large autonomy is required. The Sport Education Model is a very inclusive model aimed at ending absenteeism among students (Siedentop, 1994, Hastie 1998).

As a pre-service teacher, player and handball coach the usage of this model to teach handball was very arresting. The perception that it is very difficult to teach handball at school, mainly due to the lack of appropriate spaces, was another reason to apply the model. So, we used a learning constructivist approach, based on modified forms of the game, to promote not only motor skills and game sense learning but also responsibility, autonomy and cooperation between students. The purpose of this study was to evaluate the impact of the Sport Education Model in handball teaching in various domains of student learning: social, cognitive and motor. Additionally it was analyzed the way that the pre-service teacher experienced and felt the application of the model and the student's perception of its effectiveness.

METHODS

Context

This experience occurred during the Practicum (Master degree in Physical Education in Faculty of Sport, University of Porto), in the school year 2009-10.

Participants

Twenty-four students (12 male and 12 female) - a full 10th grade class (15-16 years old) from a School located in the Porto District - were selected. A pre-service teacher was in charge of the class.

Description

This action-research comprised 12 teaching sessions of 90 minutes each (in the 2nd term). The initial and final evaluations, four most important lessons and the culminating event, were video recorded to allow a more detailed and rigorous observation of student's motor behavior. The pre-service teacher was interviewed at the beginning and at the end of the didactic unit, and also at the beginning and end of the four most important lessons. Six students (boys and girls) from different levels were interviewed at the end of each season and during the same four lessons. The students' evaluation focused on the three domains of learning: social, cognitive and motor.

Data Collection and Analysis

Specific instruments were developed to collect the data:

- A motor test was constructed based on the *Game Performance Assessment Instrument* (GPAI) (Oslin et al., 1998) as a means of evaluating essential skills and game play performance. The target behaviors were defined after consultation of handball teachers and expert coaches. These behaviors were grouped in the following categories: skill execution, decision making in attack and decision making in defense. The individual performance was classified as an appropriate/efficient or inappropriate/inefficient response to each game situation observed. The behaviors and adequacy data were recorded in the following variables: *game involvement* - total sum of appropriated responses; *decisions made index (with the ball)* - ratio of appropriate decisions made by inappropriate decisions made; *decisions made index without the ball* - ratio of appropriate decisions made by inappropriate decisions; *skill execution index* - ratio of efficient skill executions by number of inefficient skill executions; *game performance* - arithmetic mean of the three indexes.
- A declarative test was constructed to evaluate the knowledge and understanding of the handball game.
- A socio-affective questionnaire was adapted from Tjeerdsma et al. (1996) to record the students' subjective evaluation of the didactic unit both in terms of enjoyment and learning effectiveness (self perceptions of developed competence).
- Another open questionnaire recorded the *Critical incidents* - the most memorable moments experienced by the students.

The full set of end-term interviews to the students and pre-service teacher as well as a review of his daily notes and class planning forms was analyzed for extraction of qualitative data to complement the quantitative results.

Teaching Unit

We used basic forms of handball play with gradual complexity aligned with the students' tactical understanding and level of skills. The initial evaluation was used to observe their game play competence and to decide the basic form of play. The results from the first evaluation showed a high heterogeneity among students and two different levels of play (introductory and elementary). We decided to start with the first basic form of play (1st level), which included the five against five (5v5) with individual defense. The principles of zone defense were introduced progressively (second basic form play). These approaches derived from 4 stages of learning handball at elementary and middle school proposed by Moreira et al. (2008).

Table 1 – Skills of basic game forms:

Basic game form: 1 st level	Basic game form – 2 nd level
Collective Organization	
Game 5x5, with individual defense	Game 5x5 with individual defense in restricted space
Rational space occupation	Zone defense introduction Rational space occupation
Technical and Tactical individual: Offensive skills	
Offensive basic position and dribble	Offensive Basic position and dribble
Pass and receive the ball	Pass and receive the ball
The running and bouncing shots	The running, bouncing and jump shots
Movement to open space	Movement to open space
Faking without the ball - duels	Faking with and without the ball - duels
Technical and Tactical individual: Defensive skills	
Defensive basic position	Defensive basic position - sliding
Defensive displacement	Defensive displacement
Tackling	Tackling
Defensive control	Defensive control Blocking
Offensive tactical Intensions	
Rational game space occupation	Rational game space occupation (attack positions)
Support (off-the-ball movements to open a passing line)	Support (off-the-ball movements to open a passing line) Play in the open space between the defenders
Running towards the goal with intention to shoot	To create numerical superiority
Defensive tactical Intensions	
Right framework (Goal Defense)	Right framework (Goal Defense)
Avoid the offensive progression	Avoid the offensive progression
Ball Interception	Ball Interception Cover (mutual aid)
Tactical Group	
“Pass and move” (keep the ball and progress to the goal)	“Pass and move” (keep the ball and progress to the goal) Consecutive penetrations into the defensive space “Crossing” Cover (mutual aid)

Sport Season Design

- The season involved pre-season activities, practice and competition.
- Teams– the class of 24 students was divided into three equal teams. Each team selected the coach among their members, and choose the team name.
- Team roles included player, player-coach, referee, official, statistical, journalist or material responsible.
- Space – the matches were realized in a Mini-Handball field.
- Competitive table – the competition was organized in three phases over the entire season, with nine games in total (all teams competed in all phases).
- Rules Adjustment –some formal rules were adapted.

Materials developed for the students

It was necessary to build materials to support the students' activities and roles. The Team Manual incorporated a brief characterization of Sport Education Model, the adapted rules, the description of the game principles and roles, materials and recommendations for the activities. The Coach Manual is a compilation of critical exercises to improve the skills and game sense. The coach was in charge of the selection of exercises for the session as well as the organization of the team.

DEVELOPMENT

The results indicated that the application of this model resulted in significant increase in students' learning capacity in various domains.

Motor and Cognitive learning

In general the students increased their level of competence in the handball game. The results from the initial and the final evaluations are presented in table 2. Improvements were observed in both the motor and cognitive tests, particularly in *skill execution* ($p = 0.005$) and in *game performance* ($p = 0.003$). However the *decisions making indexes* (with and without ball) didn't reveal any improvements. Results from the declarative test confirmed that the students were more knowledgeable about the rules, skills and tactical behaviors' at the end of the unit ($p < 0.001$). These findings corroborated our (field experience based) beliefs about the effectiveness of engagement in skill acquisition (Hastie, 1998) and understanding of the game (Werner et al., 1996).

Table 2 – Initial and final evaluation

Game parameters	Initial evaluation	Final Evaluation	<i>T value</i>	<i>P value</i>
<i>Decision making without the ball</i>	2.56±2.81	4.08±4.93	-1.96	.063
<i>Decision making with the ball</i>	2.12±2.33	2.92±3.11	-1.87	.07
<i>Skill execution</i>	1.18±1.29	2.50±2.47	-3.12	.005*
<i>Game performance</i>	1.96±1.73	3.17±2.95	-3.39	.003*
<i>Game involvement</i>	75.33±32.48	70.09±36.31	0.67	.508
<i>Declarative test</i>	0.85±0.07	0.92±0.07	-4.84	.000*

*significant difference for $p \leq 0.05$.

Personal and Social Domains

The obtained psychosocial development by the application of this model exceeded our expectations as substantial learning gains were reported in the three major areas of observation: autonomy, responsibility and motivation. The commitment, cooperation and involvement of students were key points for this improvement. Typically the player-coach and/or the most skilled players realize that without all members of the team contributing, it is hard to win the

competition (Carlson, 1995). On the other hand, the low-skilled players became engaged with their one learning because they perceived its importance for the team performance (Hastie, 1998). Also the participation in organization tasks by each team revealed to be very important to the development of group spirit, cooperation, integration, responsibility, autonomy and enthusiasm. This dynamic contributes to living together and respecting others, one of the key objectives of Physical Education.

The team roles contributed greatly to the development of leadership in coaches and the responsibility among students. Also, this model gives the opportunity for less skilled students to participate and to play an important role in their team's success. The competitive organization environment in organized championships over the entire season was the main important aspect for the pleasure by means of the competition, festival and fair-play. At this moment we have no doubt about the importance of competition to develop a "good game" and enthusiasm to practice sport, in this case handball. As Siedentop (1994) advocates this model promotes interest and meaning in sports activities.

Student's perceptions

- Socio-affective questionnaire

To analyze the student's perceptions we studied their feelings about some principles of the model. So the students were asked about the "pleasure" of these aspects (Table 3).

Most students enjoyed working with the same colleges during all the season (88%), in a closed team setting. Several students considered that group spirit, cooperation, assistance and trust were reinforced among colleagues and this was a main cause of satisfaction.

The competition challenge throughout the "sport season" was also referred to as a positive aspect for the majority of the students (92%). It was one of the reasons that contributed to the interest and participation in the class. Some students have referred to the originality of the organization and the similarity with the official competition as the main reasons for being so enthusiastic about this model. The culminating event created enthusiasm and satisfaction for a large percentage of students (84%). When reported to the festive nature of the classes, a large percentage of students (84%) appreciated the involvement of all students, without exceptions, and created affiliations with their colleagues from the team.

The result update, the team rankings and records were seen by the students (79%) as very important to follow and to compare the performance among other teams.

Table 3 – Feelings about the "Sport Season"

	TD	D	NO	A	TA	*Agreement %
I liked to participate in the same team throughout the season	4%		8%	38%	50%	88%
I liked the competitive challenge			8%	71%	21%	92%
I liked the culminating event	4%	8%	4%	46%	38%	84%
I liked to have access to the scores and team records			21%	50%	29%	79%
I enjoyed the festive nature of the classes by using a lot of accessories	4%	4%	8%	71%	13%	84%
I learned a lot about Handball	4%	4%	8%	63%	21%	

Legend: TD – totally disagree D – disagree NO – no opinion A – agree TA – totally agree

*agreement percentage = % A + % TA

- Critical Incidents

The analysis of the critical incidents revealed that the game and the involved roles were the most important aspects for the students. The enthusiasm, fun, competitiveness, fair-play and opportunity to assume new responsibilities were the most noticed reasons for these feelings. The following students' statements illustrate these aspects:

"Every class had fun, but as always, the game was the most memorable moment because it was something very exciting and fun" (Manuel, class 9).

"The competition between the teams was what impressed me more because there was fair play and it's always nice to see that sport is useful to bring together people" (Margarida, class 4).

"One of the things that impressed me more was to watch and evaluate the game" (being the official table). It was funny to evaluate the fair-play and how teams react to the referee decisions" (Filipa, class 4).

CONCLUSION

The fields related with autonomy, responsibility, cooperation and competitive spirit, were the features with major impact in students. In general, the students considered this model very positively, because it improved the engagement between colleges', the participation in the class activities, as well as their motor skills and game knowledge in handball. For both (students and pre-service teacher) this type of didactic unit structure and its "philosophy" was seen as an innovative and attractive process that promote enthusiasm, interest and pleasure in all the participants of the class. In summary, we want to emphasize the value of this approach both in the pre-service teacher and students' development.

antonioferreirafadeup@gmail.com

COMPETITIVE ANXIETY AND STRESS IN YOUNG HANDBALL PLAYERS

Patricia Irene SOSA GONZALEZ(1) & Juan Francisco OLIVER CORONADO(2)

- (1) Royal Spanish Handball Federation & Faculty of Sport, University Pablo de Olavide, Seville, Spain. Member of the Union of University Handball Teachers (UUHT) and EHF Master Coach.
- (2) Royal Spanish Handball Federation & Faculty of Sport, University Pablo de Olavide, Seville, Spain. Member of the Union of University Handball Teachers (UUHT) and IHF Lecturer

Abstract

This study aimed to know about competitive anxiety and stress in young Spanish federated handball players, and to examine possible significant differences in these variables depending on sex, and age. The results obtained show low mean scores in both variables, and significant differences in competitive anxiety depending on sex, and in stress depending on age. These differences should be taken into consideration when training with young handball players.

Keywords: handball, competitive anxiety, stress, young handball players

Introduction

Related to the study of the evaluation of emotional processes in sports, anxiety and stress are probably the most interesting constructs that have generated among researchers, because they have always been given a strong weight in the final performance of the athletes (Jaenes, 2001). However, anxiety still remains one of the most researched and discussed topics in psychology, has not yet reached a final and complete conclusion of this emotional phenomenon as complex (Lopez and Lozano, 2006).

Dosil and Caracuel (2003, p. 174) refer to one of the emotions that were previously learned, and define it as "a set of reactions to a situation (stimuli) can occur in which something threatening, aversive harmful, dangerous or simply unwanted". For Gould, Greenleaf and Krane (2002, p. 209) these reactions are "feelings of nervousness and tension associated with the activation level of the organism". However, it should be pointed out as notes Dosil (2004), that the situations are neutral and that the person associated with those thoughts or feelings threatening, dangerous ..., trigger anxiety. Landers (1980) and Landers and Boutcher (1986) argued that anxiety could be defined as an unpleasant emotional reaction that accompanies the activation of the autonomic nervous system and is a maladaptive emotional condition.

One of the most important pioneering authors in the study of competitive anxiety was Martens. This author takes the definitions of Spielberger about state anxiety and trait anxiety (Spielberger, 1966) referring to a concrete situation: sports competition.

As to stress, is another most studied variables or constructs in Sport Psychology. However, in this case there is no a valid definition for all authors. Thus, Fletcher and Hanton Mellaliu (2006, p. 329) define it as a "continuous process involving the interactions of individuals with their environment, assessing the situations in which they find themselves in an effort to address any issues you see". The theory of stress and coping of Lazarus and Follkman (1984) defines the process of stress as the result of an imbalance between demands and personal resources person-environment relationship.

According to Buceta (2004) stress is a reaction of the organism to situations that are threatening. It may be beneficial in small doses, if handled correctly, but is harmful when it is excessive and there is no ability to control it. The experience of stress occurs when the athlete perceives an imbalance between the demands that are imposed and skills (Baumann, 1993; Bump, 1989; Martens, 1987). This imbalance can be both a positive direction and toward the negative, in both

cases the performance will be affected. In any case, it is important that the psychological repertoire of the athletes have skills or skills that allow you to manage stress properly (Baumann, 1993; Eberspacher, 1995; Gould, Wilson, Tuffey and Lochbaum, 1993; Hall and Purvis, 1980; Hanin, 1980; Márquez, 2006; Nideffer, 1980; Scanlan, 1984). In addition, these they will be useful in their daily lives. To use appropriate techniques that can cope with stress, the coach and the athletes must first know the causes and effects of stress (Sosa, 2007; Valdés, 1996; Weinberg and Gould, 1996).

Athletes who use coping strategies that are incorrect or are unable to properly interpret the events related to sports activity and to react in a rational way, experience chronic stress and prolonged resulting in a deterioration in the ability to execute and even the occurrence of burnout and abandonment sports (Wheaton, 1997).

Objective

The aim of our research was to determine the competitive anxiety and stress in Spanish handball players of both sexes, 13 to 16 years, and to analyze whether there were significant differences in these psychological variables by gender and age.

Method

Participants:

Our study sample consisted of 642 young Spanish handball from 13 to 16 years ($M = 14.82$, $SD = 1.01$), who participated in the Championship of Spain of Territorial Selections sports in their respective categories, age 302 old children and 340 cadet, 313 boys and 329 girls.

Measuring Instrument:

As data collection instrument we used the scales of situational anxiety and stress -applying small changes- the "Battery of psychological tests for Athletes - Salamanca" (btpd-S), Fernández-Seara, Fernández-Navarro and Mielgo (1999). These scales are composed of a series of items or statements about sport and competitive activity that must be answered by pointing t (true) or f (false) depending on the athlete believes fit it into its way of being or acting .

The scale of situational anxiety in sport, or competitive anxiety scale, consists of 34 items and the scale of stress in sport 27 items. The scores for each scale are obtained by adding the values assigned by correction format for each of the response options. So, you get two different scores directly reflect the level of each variable evaluated.

The small changes we have made the instrument of measurement after carrying out various types of preliminary psychometric analysis in order to improve both its components and their properties have been taken into account in all data analysis (Sosa, 2008).

Procedure:

Athletes volunteer participants completed the two scales of the battery, accompanied by a personal data sheet, sports and socio-demographic, the day of his arrival at the venue of the Championship. These data and the responses of each participant were stored and analyzed using SPSS version 15.0.

Results and Discussion

Table 1 presents the descriptive results (mean, standard deviation, minimum and maximum) and inferential, using *t*-tests for two independent groups, obtained by the full sample, by sex and age in the two scales or variables analyzed. It shows that there were significant differences in competitive anxiety by sex, with higher scores in women than in men.

Depending on the age differences were significant in the stress variable, where under 16 years old players get higher average scores than under 14.

Table 1. Descriptive and inferential results for the full sample, by sex and age in the two variables.

		N	Subscales	Mean	Standard deviation	Minimum	Maximum	<i>p</i>
Full sample		642	competitive anxiety	9,40	6,36	0,00	31,00	
			stress	4,95	4,18	0,00	23,00	
Sex or Gender	Male	313	competitive anxiety	7,85	6,21	0,00	25,00	0,000**
	Female	329		10,87	6,16	0,00	31,00	
	Male	313	stress	4,70	4,35	0,00	23,00	0,136
	Female	329		5,19	4,00	0,00	23,00	
Age	Under 14	302	competitive anxiety	9,26	6,31	0,00	25,00	0,611
	Under 16	340		9,52	6,41	0,00	31,00	
	Under 14	302	stress	4,42	3,88	0,00	21,00	0,002**
	Under 16	340		5,41	4,38	0,00	23,00	

* $p < 0,05$. ** $p < 0,01$

Table 2 presents the average scores for both the entire sample and by sex and age in the two psychological variables analyzed, transformed into a single scale of most common measure of 0 (minimum) to 10 points (maximum) in order to facilitate the reader management, interpretation and comparison of the results of both variables.

Table 2. Mean scores on a scale from 0 (minimum) to 10 points (maximum) for the full sample, by sex and age in the two psychological variables analyzed.

Subscales	Full sample	By sex		By age	
		Male	Female	Under 14	Under 16
	Mean	Mean	Mean	Mean	Mean
competitive anxiety	2,76	2,34	3,20	2,72	2,80
stress	1,83	1,74	1,92	1,64	2,00

As reflected in Table 2, the average scores for the full sample in both competitive anxiety as stress are quite low (2.76 and 1.83 over 10 points), as in the two groups analyzed, where both in competitive anxiety and in stress are women and older age group-cadet-athletes who scored high versus low scores on both variables in men and in the group of younger athletes and child.

Few studies have examined the effects of sex on the intensity of competitive anxiety response have generally found higher levels of competitive state anxiety and trait in women than in men (Jones & Cale, 1989; Martens, Burton, Vealey, Bump & Smith, 1990).

Tabernero and Márquez (1993) studied gender differences in the components of competitive anxiety, finding that women showed higher values than men at all levels of causes of anxiety (cognitive anxiety, absence of control of external determinants, anxiety and social sense of inadequacy). These results are in line with those obtained by Martens (1977), reflecting that women generally scored higher on trait anxiety. According to Jones and Cale (1989), in the moments before the competition was a marked increase in cognitive anxiety and decreased self-confidence, attributed to a failure of regulation by the lack of experience. As we approach the start of the competition in women is a progressive increase in cognitive anxiety, while in men no change. Sanderson (1989) found little difference between men and women in terms of state anxiety prior to competition, although they noted that women showed an increase earlier in the somatic anxiety than men.

With respect to age, we expected that the older, lower scores would be competitive anxiety and stress since they need more skills than control of the situation and coping strategies, but that has not happened, so we must also consider these data in the psychological preparation of our athletes. These results are in line with those obtained by Godoy-Izquierdo, Velez and Prada (2007, 2009), indicating they too, like us, the need to include psychological training in comprehensive sports training for athletes to provide them psychological skills that enable them to adequately address the growing demands of the sport with increasing age and level of involvement in both individual and collective forms.

It is definitely very positive test levels so low that show our young athletes in competitive anxiety and stress. In this regard, most studies in this area has found that most children do not suffer from excessive stress and anxiety pre-competitive, although a significant proportion, around 10%, which does show problems of anxiety and stress . In these cases or circumstances, stress and anxiety it can be a problem for young athletes.

In general, compared with stress during training, competition stress is not significantly greater, or in relation to which children manifest in other types of performance testing or evaluation (Weinberg & Gould, 1996). However, we must take into account the competitive stress, anxiety and related factors for the victory pressure related to the performance of coaches and the competition itself becomes the main reason for drop with increasing age, and this is more clearly perceived by players as they grow (Cruz, 2001). According to Weinberg and Gould (1996), some psychologists suggest that, on the contrary, a well-posed and organized environment need not lead to excessive stress experience a plus athletes teach coping strategies that may be transferred to other aspects of their lives. In this sense, the sports environment serve as "vaccine" against stress by allowing them to learn effective coping strategies in stressful situations recently, which can then be applied to more complicated or challenging situations.

Conclusions

Based on the results of our study we want to highlight the poor results in competitive anxiety and stress, and that there are significant differences in competitive anxiety by sex, and in stress as a function of age, differences to take into account when working with young athletes in the context of sports training and competition, being necessary to integrate psychological training in comprehensive sports training for athletes. In addition, there is evidence that both anxiety and stress sports are closely linked to several other psychological variables and play an important role regarding the performance, satisfaction and adherence to the activity, not only in the world of sport, but in all areas of life.

pisosgon1@upo.es

PSYCHOLOGICAL CHARACTERISTICS OF YOUNG HANDBALL PLAYERS AND ITS IMPORTANCE FOR HANDBALL COACHES

Patricia Irene SOSA GONZALEZ(1) & Juan Francisco OLIVER CORONADO(2)

- (1) Royal Spanish Handball Federation & Faculty of Sport, University Pablo de Olavide, Sevilla, Spain. Member of the Union of University Handball Teachers (UUHT) and EHF Master Coach.
- (2) Royal Spanish Handball Federation & Faculty of Sport, University Pablo de Olavide, Sevilla, Spain. Member of the Union of University Handball Teachers (UUHT) and IHF Lecturer.

Abstract

The aim of the present study was to assess a series of psychological characteristics among young Spanish handball players (under 14 and under 16), and to examine possible significant differences in these characteristics depending on sex, and age. The results obtained show that there are significant differences in most of the assessed variables, something very important to be taken into account by their coaches.

Keywords: *assessment, psychological characteristics, young athletes, handball*

Introduction

The scientific literature that exists in Sport Psychology on traits, characteristics, abilities and psychological variables related to athletic performance is particularly extensive. However, despite the abundance of these types of studies we have found a few related to handball.

On research that analyze different characteristics or psychological variables and their relationship to athletic performance in our country (Spain), reviewing the work of Llames (2003), which analyzes the predictive power of certain variables, such as motivation, precompetitive anxiety, self-confidence, etc., on performance in soccer players.

Related to the self-control Cecchini, Montero and Peñaa (2003) examined the impact of an intervention program to develop personal and social responsibility on fair play behaviors and self-control in young school with a sample of 142 students with an average age of 12.7 years.

Vera, Hernández, González-Cutre, Navarro and Moreno (2008) conducted a study related to sport competition and perceived gender differences in young school in sports ball.

About cohesion, Alzate, Lazaro, Ramírez and Valencia (1997) analyze the impact of the coach's communication style in the development of group cohesion, collective efficacy and satisfaction in handball, with a sample of 84 players (45 women and 39 men), belongin to 8 teams from 1st and 2nd Division.

García-Calvo, Sánchez, Leo, Jiménez and Cervelló (2008) analyzed with a sample of 492 soccer players between 13 and 18 years thr relationship between the theory of achievement goals and self-determination theory with group cohesion, and what are the main antecedents of sporting cohesion, and what can predict it at motivational level.

Finally, we note that in the practice of handball competition, like in most sports, are involved a lot of psychological issues, both before, during, and after the competition. Highlight for example, aspects such as psychological preparation, concentration, coping with stress, flow

(Csikszentmihalyi, 2003), emotional control, self-control, self-confidence and competitiveness, among many others, so that knowledge and training of these variables may contribute to that athletes optimize their performance.

We agree with Tutko and Richards (1984) that the coach should be sensitive to individual differences in athletes, that is why for them is essential to understand the particularities of each one, task that undoubtedly represents a great challenge. This requires knowing the psychological characteristics of athletes, their needs, mental abilities, and skills, before, during and after the competition, as a first step to help improve both their sporting performance, as their integrated development as young people in formation, always working together and integrated all professionals of the technical team.

Objective

The aim of our research was to determine and analyze a number of psychological characteristics of Spanish handball players, under 14 and under 16 years old, both sexes, who practice competitive sport, as well as whether there were significant differences between these athletes on the results obtained in the different variables by gender and age.

Method

Participants:

Our study sample consists of 642 handball players aged 13 to 16 years ($M = 14.82$, $SD = 1.01$), 302 U 14 and 340 U 16, of which 313 are boys and 329 girls. All are federated, practice competitive sport and have been previously selected from among all the other players in their respective category licensed sports federation in the Territorial Federation.

Measuring instrument:

As data collection instrument we used the subscales of self-control, sport anxiety, self esteem, confidence and security, perceived competence and cohesion in sport -applying small changes- the "Battery of Psychological Tests for Athletes - Salamanca" (BTPD-S in spanish) by Fernández-Seara, Fernández-Navarro and Mielgo (1999).

These subscales are each composed of 11 items or statements about sport and competitive activity that must be answered by pointing t (true) or f (false) depending on the athlete believes fit it into its way of being or acting. The scores for each subscale are obtained by adding the values assigned by correction test for each of the response options. So, you get 6 different scores that directly reflect the level of the variables evaluated.

The small changes we have made to the measuring instrument were made after carrying out various types of preliminary psychometric analysis, in order to improve both its components and their properties and have been taken into account in all data analysis (Sosa, 2008).

Procedure:

Athletes volunteer participants completed the questionnaire, together with a sheet of personal data, sports and socio-demographic, the day of his arrival at the Championship. These data and the responses of each participant were stored and analyzed using SPSS version 15.0.

Results and Discussion

Table 1 presents the descriptive results (mean, standard deviation, minimum and maximum) and inferential, using *t*-tests for two independent groups, obtained by the full sample, by sex, and by age, in the 6 subscales and variables analyzed. It reflects how by gender found significant

differences between men and women in the 6 variables analyzed: self-control (absence of) sport anxiety, self esteem, confidence and security, perceived competence and cohesion.

Depending on the age differences were significant only in self-control, and in this variable the U 14 age group obtained a mean score higher than the U 16 age group.

Table 1. Descriptive and inferential results for the full sample, by sex and by age in the 6 variables analyzed.

		N	Subscales+	Means	Standard deviation	Minimum	Maximum	p
Full sample		64	act	8,80	1,75	1,00	11,00	
			ans-d	5,88	2,52	0,00	11,00	
			aes	6,58	2,11	0,00	11,00	
			acs	7,09	2,24	1,00	11,00	
			cp	8,48	1,59	2,00	11,00	
			coh	9,93	1,30	2,00	11,00	
Sex or Gender	Male	31	act	8,96	1,78	1,00	11,00	0,020*
	Female	32		8,64	1,71	3,00	11,00	
	Male	31	ans-d	6,59	2,39	0,00	11,00	0,000**
	Female	32		5,21	2,46	0,00	11,00	
	Male	31	aes	7,26	2,03	1,00	11,00	0,000**
	Female	32		5,93	1,98	0,00	11,00	
	Male	31	acs	7,86	1,98	2,00	11,00	0,000**
	Female	32		6,35	2,22	1,00	11,00	
	Male	31	cp	8,65	1,59	3,00	11,00	0,009**
	Female	32		8,32	1,57	2,00	11,00	
	Male	31	coh	9,70	1,55	2,00	11,00	0,000**
	Female	32		10,16	0,95	3,00	11,00	
Age	Under	30	act	9,08	1,60	3,00	11,00	0,000**
	Under	34		8,55	1,84	1,00	11,00	
	Under	30	ans-d	5,85	2,60	0,00	11,00	0,807
	Under	34		5,90	2,45	0,00	11,00	
	Under	30	aes	6,70	2,09	1,00	11,00	0,161
	Under	34		6,47	2,13	0,00	11,00	
	Under	30	acs	7,12	2,29	2,00	11,00	0,721
	Under	34		7,06	2,19	1,00	11,00	
	Under	30	cp	8,58	1,53	2,00	11,00	0,122
	Under	34		8,39	1,63	3,00	11,00	
	Under	30	coh	9,98	1,13	5,00	11,00	0,380
	Under	34		9,89	1,43	2,00	11,00	

+ Act: self, ans-d: (lack of) anxiety sport; aes: self-esteem; acs: self-confidence and security; cp: perceived competence, coh: cohesion

* $p < 0.05$. ** $p < 0.01$

Table 2 presents the average scores for the whole sample, by sex and by age in the 6 variables analyzed psychological transformed into a single scale of most common measure, from 0 (minimum) to 10 points (maximum) and ordered from highest to lowest mean score in order to facilitate the reader's interpretation and comparison of results. Similarly, and for the same purpose, we transformed scores on (absence of) sport anxiety, and we talk about sport anxiety in terms of presence.

Table 2. Mean scores on a scale from 0 (minimum) to 10 points (maximum) for the full sample by sex and age, in the 6 psychological variables analyzed.

Subscales (ordered from highest to lowest mean score)	Full sample	By gender		By age	
		Male	Female	Under 14	Under 16
	Mean	Mean	Mean	Mean	Mean
1ª cohesión	9,03	8,81	9,24	9,07	8,99
2ª autocontrol	8,00	8,14	7,85	8,25	7,77
3ª competencia percibida	7,71	7,86	7,56	7,80	7,63
4ª autoconfianza y seguridad	6,45	7,14	5,77	6,47	6,42
5ª autoestima	5,98	6,60	5,39	6,09	5,88
6ª ansiedad deportiva	4,65	4,00	5,26	4,68	4,64

As reflected in Table 2, all comparison groups registered higher average scores on cohesion and self-perceived competence, and the lowest in sport anxiety, self esteem, and self-confidence and security.

Highlight low values are reached in self-esteem and confidence and security, fundamental aspects in the psychological development of a child and a teenager (Buceta, 2004), something to keep in mind to work in the training sessions strategies that affect an increase and / or strengthening them. This in turn will result in strengthening the beliefs of perceived competence and sense of self, and very likely to decrease further the sport anxiety.

As for the self-confidence, as stated Dosil (2004), it is necessary to deal with any situation guarantees and-sporting sports. Realistic assessment of the situation they face and their own resources to do so, and anticipating the most likely problems and what to do, are the basis on which to lay a solid self-confidence. Similarly, setting goals and challenging but realistic plans is a good choice to use and take advantage by coaches, through attractive targets, realistic and focused on performance and not the result of competitions, so that the athlete to step up, or gradually regaining credibility in their abilities. Careful planning and realistic goals achievement are essential to achieve or regain the self-confidence of athletes (Buceta, 2004; Locke and Latham, 1991; Nideffer, 1981; Smith, Smoll and Curtis, 1991).

On the other hand, although the average score higher on the cohesion variable, we should continue to foster the maintenance of it. To this end, should consider following the sport cohesion model of Carron, Brawley, and Widmeyer (1998), both the individual aspects - individual attractions to the group, and group - group-integration-, with its orientation towards aspects team membership social (social cohesion) and to aspects of task, or objective of the team (together by the task).

Also, in spite of to be among the scores high, we cannot forget about self-control, because for an athlete it is very important teaching them to control their energy, their impulsiveness, their

emotions and behavior in general, so these factors impact on their performance or athletic performance in the most appropriate, especially in adverse situations in which the self-control is harder and takes on greater importance (Buceta, 2004).

Regarding the perception of competence of our athletes, we help them feel competent foundation both in its execution or sports performance, and in their motivation and many other areas of life. Authors and Wiersma (2001) highlight the importance of perceived competence as a key factor for the enjoyment of sport and adherence to it. The perception of competence will depend largely on the direction that sports coach give their athletes: domain-oriented skills (intrinsic motivation) or results-oriented (extrinsic motivation).

So the coach, conveniently advised by the sports psychologist in collaboration with him on his psychological training functions in the sport, can and should, in its performance, strengthen these psychological characteristics to their young athletes to optimize their learning not only , execution and performance of undoubted role in sports training, but also to improve the satisfaction, enjoyment and adherence of their athletes and beyond, contribute to the development of these young people.

Conclusions

We believe that the information obtained through the results of our study regarding the set of variables analyzed is very important, and coaches should keep it in mind both in the context of training and sports competition, since, as we have seen there are many aspects that differentiate our athletes -each athlete is different from others-, and all these psychological variables play an important role not only in the world of sport, but in all areas of life.

pisosgon1@upo.es

PSYCHOLOGICAL VARIABLES RELATED TO MOTIVATION AMONG YOUNG ATHLETES OF HANDBALL WHO PRACTICE COMPETITION SPORT

Patricia Irene SOSA GONZALEZ(1) & Juan Francisco OLIVER CORONADO(2)

(1) Royal Spanish Handball Federation & Faculty of Sport, University Pablo de Olavide, Seville, Spain. Member of the Union of University Handball Teachers (UUHT) and EHF Master Coach.

(2) Royal Spanish Handball Federation & Faculty of Sport, University Pablo de Olavide, Seville, Spain. Member of the Union of University Handball Teachers (UUHT) and IHF Lecturer.

Abstract

The aim of the present study was to assess a series of psychological variables related to motivation among 642 Spanish handball players, 13 to 16 years old ($M= 14,82$; $sd = 1,01$), 313 boys and 329 girls. The results obtained should be taken into account when working with young players to reinforce these aspects to increase, or maintain, their interest in practicing sports, and avoid, or at least diminish, their premature abandonment.

Keywords: *handball, assessment, motivation, young handball players*

Introduction

In recent years, a considerable number of investigations have highlighted the importance of psychological variables such as stress management, management of concentration, self confidence, motivation, management of mental abilities, and so on. in the pursuit of athletic success. In all areas of operation that involves competitive sport psychological variables have a significant importance, such as motivation, attention, stress, anxiety, self-confidence, mood, self-control and self-regulation, cohesion, interpersonal skills or emotional adjustment in line with what is stated by many experts (Buceta, 1990, 1996a; Capafons, Labrador and Gil, 1993; García, Rodríguez, Andrade and Arce, 2006; Gimeno and PÉrez-Llantada Buceta (2007); Loehr, 1984; Mahoney, Gabriel & Perkins, 1987; Orlick, Hansen, Reed and O'Hara, 1978; Ravizza, 1975; Roberts, 2001; Van der Auweele, Cuyper Van Mele and Rzewninicki, 1993).

The knowledge and the training of these variables can help athletes optimize their performance thus increasing the chances of getting better sport on the one hand, and to reduce the incidence of variables that can affect their performance and continuity in competitive sport in the long term, on the other.

With respect to motivational variables, there are many links between all the theories that attempt to explain the complex and dynamic processes associated with it, since this is considered a multidimensional and dynamic construct that can be analyzed from different theoretical constructs and exercises a key role in any area of behavior, recognized as one of the most important constructs in the sporting context.

In the practice of handball competition, like in other sports, are involved a lot of psychological issues, both before, during, and after the competition. Noted, for example, aspects such as psychological preparation, concentration, coping with stress, flow (Csikszentmihalyi, 2003), emotional control, self-control, self-confidence and competitiveness, among others. Thus, the role of psychological training or Applied Sport Psychology passes or meet examine psychological characteristics of athletes, their needs, mental abilities, skills and expertise before, during and after the competition.

All the above justifies the importance of conducting research as we presented here, related to the study of a series of psychological characteristics or variables of athletes in our case of Handball in the context of competitive sport, and child-specific youth sport, in order to better understand the reality of their psychological needs as a first step to help improve both their sporting performance, as their development as young people in training, always working together integrated, all professionals in the technical team.

Objective

The aim of our research was to find a number of psychological variables related to motivation Spanish handball players, 13 to 16 years old (under 14 and under 16) of both sexes and practicing competitive sport.

Method

Participants:

The sample in our study consists of the best sports handball players under 14 and under 16 years old who participated in the Spain Championship of Territorial Selections in their respective sports category.

This is a total of 642 handball players, 13 to 16 years ($M = 14.82$, $SD = 1.01$), of which 313 were boys and 329 girls.

Measuring instrument:

As data collection instrument we have used the 4 subscales of motivation in the sport of the "Battery of Psychological Tests for Athletes - Salamanca" (BTDP-S in Spanish), Fernández-Seara, Fernández-Navarro and Mielgo (1999), based to which have been studied, -applying small changes-, 4 psychological variables related to motivation: achievement motivation, narcissism motivation, social affiliation and social recognition and prestige.

These four subscales related to motivation are composed of between 5 and 10 items or statements about sport and competitive activity that must be answered by pointing t (true) or f (false) depending on the athlete believes fit it into its way of being or acting.

These subscales include motivation narcissistic, which includes 5 of the 8 items that comprise it, that what is measured (absence of) motivation narcissistic because we believe that the rest did not evaluate this dimension; social affiliation, with 8 items; prestige and social recognition, which in our study is with 6 of the 8 original items for the same reasons as in the case of narcissistic motivation subscale, and achievement motivation subscale, which is finally formed by 10 items.

Small modifications presented here and that we have made the instrument of measurement after carrying out various types of preliminary psychometric analysis, in order to improve both its components and their properties have been taken into account in all data analysis (Sosa, 2008).

Total scores are easily obtained through a series of correction format, one for each of the 4 subscales and variables. The scores for each subscale are obtained by adding the values assigned by the templates to each of the response options. Thus, 4 different scores are obtained directly reflect the level of the variables evaluated.

Procedure:

Athletes volunteer participants completed the questionnaire, along with a personal data sheet, sports and socio-demographics, the day of his arrival at the venue of the Championship. These data and the responses of each participant were stored and analyzed using SPSS version 15.0.

Results and Discussion

Table 1 presents the descriptive results (mean, standard deviation, minimum and maximum) obtained by the full sample in the 4 subscales and variables measured.

Table 1. Descriptive results of the sample.

Subscales	Mean	Standard deviation	Minimum	Maximum
(absence of) narcissistic motivation	3,21	1,45	0,00	5,00
social affiliation	7,20	1,21	2,00	8,00
prestige and social recognition	4,31	1,20	0,00	6,00
achievement motivation	7,52	1,65	2,00	10,00

In Table 2 we have transformed the average scores in the 4 subscales to a single scale of most common measure, from 0 (minimum) to 10 points (maximum) in order to facilitate the reader management, interpretation and comparison of 4 results of psychological variables analyzed, sorted from highest to lowest value. Similarly, and for the same purpose, we transformed scores on (lack of) motivation narcissistic, narcissistic and talked about motivation in terms of presence.

Table 2. Mean scores on a scale from 0 (minimum) to 10 points (maximum) by the sample in the 4 psychological variables analyzed.

Subscales	Mean
social affiliation	9,00
achievement motivation	7,52
prestige and social recognition	7,18
narcissistic motivation	3,58

As seen in Table 2, 3 of the 4 subscales of motivation evaluated, except narcissistic motivation, achieve higher average scores above 5, the maximum possible intermediate value of the subscales. Based on these results, it appears that social affiliation and achievement motivation are the main sources of motivation handball players, which is consistent with many studies on motives for sport in children and adolescents (Gill, Gross and Huddleston, 1983; Gould, 1980), where the main reasons that lead the child to the sport are: to learn / improve skills and have fun/enjoy being with friends, meet new people, demonstrate athletic ability when compared with other be well physically, to experience new sensations, and, far from these reasons, compete, succeed and win.

The need for affiliation or social relationship is one of the three basic needs which supports self-determination theory (Deci & Ryan, 1985) with the needs of competence and autonomy. Within this theoretical framework posits that when people interact with their environment need to feel connected with others, in connection with others, and the satisfaction of these needs is essential for the development of both self-determined motivation (Deci & Ryan, 1985) and the

psychological well-being (Ryan & Deci, 2000). This need to interact successfully with the social and the group to which they belong is in line with the results of research conducted by Molinero, Salguero del Valle, Tuero, Alvarez and Márquez (2006) on grounds of abandonment with an sample of 561 athletes, boys and girls, with a mean age of 15.2 years old and 11 different sporting disciplines, both collective and individual, since one of the main reasons for leaving was the lack of a good atmosphere or environment equipment. Thus we see the possibilities offered by the sport-and we should not miss, to contribute to this psychological well as athletes continue to play sports for intrinsic motivation, or motivation "basic" in terms of Buceta (1996b) compared extrinsic motivated more by external rewards or obligation.

Achievement motivation has taken second place in the scale of motivation of our young athletes. This variable, analyzed from the achievement goal theory is related to guidance and motivational states involved in the task, ie, designed to demonstrate mastery of a task, focusing more on the learning process than the outcome of the behavior. The criterion by which to evaluate the implementation is related to the task itself, and part of the previous run level of the individual, regardless of the performance of others is self-referential. The goal is to master the behavioral task, and the achievement of this goal is associated with increased feelings of competence (Nicholls, 1984). Likewise, based on the theory of achievement motivation proposed by McClelland (1961) that people are intrinsically motivated to establish and achieve different results or achievements, goals, and sport is a context that favors it.

In our opinion, from the standpoint of the coaches, we should reflect on these results, taking into account the motives and interests that really move our athletes in the sense of creating appropriate motivational climate, and not to apply in the sport of initiation model adult competitive sport, usually focused on achieving results immediately, forgetting the importance of process in this age of sports training and self-referential application of criteria, which values the efforts and progress of the athlete in achievement of the task domain, which normally is associated with increased feelings of competence, rather than comparisons using external references, and often too far away.

The third place is occupied by motivations related to the prestige and social recognition, which is usually related to ego-oriented athletes, who feel that sport and physical activity can help them gain greater recognition and social status, increase popularity, achieve economic wealth, and so on. Oriented behaviors in these social approval goals are not directly related to learning or achievement, but have to do with the emotional experience arising from the social response to one's own performance, while its attainment may be an instigator important motivation to achieve the objectives. For these athletes it is important to the approval of their parents, their coaches and peers. It is a type of extrinsic motivation along a continuum of self-determination.

The last, and with a significantly lower score, lies the motivation variable narcissistic, that following the same theoretical framework relates to the guidelines and ego involved motivational states of the theory of achievement goals, and within the different types of behaviors, both those aimed at the demonstration of ability as those aimed at social approval. The state of ego involvement is related to the demonstration of greater capacity than others. Under this condition, the focus is on tasks in which few have had success so we can make inferences on the possession of high capacity.

From these results we appreciate the high level shown by these athletes handball federation social affiliation, obtaining in this variable the highest average score, and very close to maximum possible (10 points), the 4 variables analyzed, followed by motivation achievement. We believe this information should have it in mind when working with young athletes, in the sense of influence and strengthen these aspects such as sports coaches to contribute to increasing or at

least maintain, their interest in sports, and thereby avoiding or minimizing premature abandonment. Also note, fortunately on the other end, the low mean score on motivation narcissistic, that is probably not the best motivational orientation for sports training and staff of these young athletes.

Conclusions

In our opinion, we consider these results as very positive, as we describe a very encouraging picture as to the motivations of our Young handball players. On the other hand, we are convinced that this type of work which seeks to make a differential evaluation of different motivational variables that influence participation and sports performance are necessary and help design and implement the most appropriate type of intervention training for the athlete. It is our obligation and our responsibility, potential opportunities afforded us by the sport to contribute to all-parents, crew, managers, judges, etc.- to optimal physical, psychological and social development of young people in this age group.

pisosgon1@upo.es

HANDBALL AT SCHOOL – DIDACTICAL GUIDELINES FOR PHYSICAL EDUCATION (P.E.) STUDENTS AND TEACHERS

Helmut HÖRITSCH, Mag.

European Handball Federation (EHF), Vienna, Austria

Summary:

A didactical framework conception for teaching handball at school shall be based on a 3-level model “Me and the Ball”, “With Each Other”, and “Team Against Team”. Appropriate teaching tools and manuals shall be offered to current and future P.E. teachers such as game and exercise sequences for developing general and specific playing skills, including facility management, pedagogical advice and new trend activities such as Beach-and Street Handball.

Keywords: Starting the game and teaching handball at school, didactical framework conception, P.E. teachers’ education at university, P.E. teacher’s further training courses

Introduction:

In 2006 the EHF carried-out the 2006 EHF Conference “Handball at School” in Innsbruck/AUT as well as the 2006 EHF Youth Handball Convention in Vienna/AUT aimed at starting a process of Europe-wide deliberations on how to pave the way for handball into schools despite the different school systems and P.E. curricula used all over Europe. In 2010/11 the International Handball Federation (IHF) started a world-wide project “Handball at School” in order to spread and promote the same concept.

Nowadays methodological handball literature in Europe is comprehensive, professional and well-fitting for the purpose of developing the sport in many countries in Europe. But – is that the right literature for the P.E. teacher at school, who is free to choose the sports and activities from a very general framework P.E. curriculum in his/her country? Does he/she know how to start the game at school or how to attract and motivate his/her pupils for the game, if he/she has never played handball him/herself? Can he/she understand methodological handball literature that is mostly lacking concrete hints for an appropriate, age-adequate didactical approach to handball? Apparently the answer is “no”!

If handball wants to be competitive with other sports that already have created concepts for both starting and promoting their activities at school and educating P.E. teachers in an appropriate way, handball experts need to create, differentiate and reflect guidelines for handball didactical competence to be acquired by current and future P.E. teachers. They have to be attracted by the team sport handball and motivated to start and develop it at school against the background and competition of other attractive team- and trend sports. “Handball at School” is a very important market for the future of handball, worth starting deliberations on how to draw the pupils’ and their teachers’ attention to the game.

Methods:

Based on my full-time professional activities for the European Handball Federation (EHF) in education, training and grass root development as well as my more than 25 years of work as an external lecturer for handball at the University of Vienna Institute for Sports Science the objective of my article is to present a specific didactical concept for P.E. university students and future teachers for simply “learning, practising and learning how to teach sport-game-oriented motor sequences in handball” which shall be offered as part of both curricula, for the university P.E. teacher education as well as for P.E. teacher further training activities.

An appropriate handball methodology – all practices, procedures and rules used by handball coaches/teachers - is important for teaching the basics of the game, but handball didactics, the

art of teaching with regard to the teaching environment and facilities available, is even more important for starting and developing handball as an attractive team sport at school.

The following proposal is clearly inspired by age-appropriate, game-appropriate and action-oriented didactic models and includes cross-references to the current state-of-the-art of teaching concepts for sport games such as handball. It goes without saying that the approach applied is a hermeneutic (=interpretive) one based on acquired knowledge from handball literature and personal, professional experience in handball teaching and working with international experts.

Development:

“The route to handball” (EHF)

The 1997 EHF publication “The route to handball” by RINCK and GUERRERO was conceived as a proposal for handball-specific methodology with didactical principles to follow for developing the game in various age categories developed by experts from leading European handball nations within the EHF.

Level	Age	Philosophy	By children for children	Game	Competition	Contents	Requirements and skills
I	up to 7	The ball as a playing companion - getting used to the ball	<ul style="list-style-type: none"> ● Come “and help” 	<ul style="list-style-type: none"> ● Preparatory games 	NO	<u>Animation:</u> 1. Getting used to the ball 2. Handling the ball 3. Motor coordination	<ul style="list-style-type: none"> ● Basic motor skills ● Learning how to fall ● Activities and games with the ball: taking up, rolling, passing, catching games
II	7-10	Mini-handball	<ul style="list-style-type: none"> ● 1 referee from among the players 	<ul style="list-style-type: none"> ● 4+1 players ● Smaller court ● Goals 2.40x1.60m ● Ball size 0 Mini-handball playing festivals	NO YES	<u>Game:</u> 1. Motivation between the player and the court 2. Physical relationship 3. Various experiences 4. Social experiences / playing festivals	<ul style="list-style-type: none"> ● Basic motor skills + passing, catching, bouncing, blocking ● Moving into free spaces, watching, running loose ● Playing elements in motion, distance and position towards the opponent Cf. EHF publication “Mini-Handball”
III	10-12	„Basic Handball 1“	<ul style="list-style-type: none"> ● 1 – 2 referees from among the teams ● 1 adult helper 	<ul style="list-style-type: none"> ● Transition phase to 6+1 ● Handball court 40x20m ● Goals 3.00x2.00m ● Ball size 1 ● Shorter playing time ● Alternative playing formats: 5+1 half of the court 2 times 3:3 	YES/ NO	<u>Game / drills:</u> 1. No adult type training 2. Development of technical / tactical skills 3. Development of physical skills 4. Playing festivals and simple competitions	<ul style="list-style-type: none"> ● Age-appropriate communication and storage of information ● Playing in motion – man marking, offensive defence, counter-attack, play on all positions ● Versatile use of speed, integrated endurance, strengthening the body using its own weight
IV	12-14	“Basic Handball 2“	<ul style="list-style-type: none"> ● 2 referees from among the teams ● 1 adult helper 	<ul style="list-style-type: none"> ● 6+1 players ● Girls: Ball size 1 ● Boys: Ball size 2 ● Shorter playing time 	YES	<u>Drill / game</u>	Cf. EHF publication “Basic Handball“
V	14 and above	Handball	<ul style="list-style-type: none"> ● 2 referees 	<ul style="list-style-type: none"> ● 6+1 players ● Girls: Ball size 2 ● Boys: Ball size 3 	YES	<u>Training / game</u>	Cf. handball-specific training theory

Theoretical didactical principles for sport game teaching at school

Based on various forms of simplification, KOLB distinguishes 5 basic didactic game concepts:

1) Analysis concept aimed at “Elementary simplification”

- Gradual learning process for the individual technical and tactical elements of the game
- Practice order
- Accomplishment of the goal is only possible after the acquisition and command of the basic techniques

Problems:

- through an isolated acquisition process, techniques are often not appropriately applied to the game.
- children are more interested in playing than practising and training

2) **Confrontation concept** (in case of problems: “**Conditional simplification**”)

- No game analysis based on individual game elements
- Students should experience the game in its entity

Problem:

- excessive demands on beginners

3) **Children-friendly concept** aimed at “**Simplification of children-friendly strategies**”

- Acquisition of individual techniques in modified small games, as well as through exercising in the form of playing.
- Game order through “relating games” – from small games to big games

Problems:

- often restricted to superficial exercises in the form of playing not including any real game forms - today children are not familiar with the canon of small games

4) **Game-friendly concept** aimed at “**Situational simplification**”

- Return to the central idea and basic conditions of the game, which are constantly expanding through the engagement of students with the core of the game: the competition-oriented, simultaneous and corresponding attack and defence acts in basic game situations.
- The basic game-form with simpler game conditions (smaller number of players, initially only one objective, less and simpler rules) is gradually expanded through the creation of more complex game situations.
- Corresponding points of the game order are introduced through the complementary exercise order. Exercises should exist in a functional interrelation with the game order.

5) **Action-oriented concept** aimed at “**Action simplification**”

Based on the assumptions of basic action structures in all games, there are five action modes:

- Ball behaviour: acquiring the ball
- Space behaviour: carrying the ball
- Goal behaviour: bringing the ball to the goal
- Partner behaviour: helping the team-mates
- Opponent behaviour: disrupting the opponent

In between game sequences, individual exercise orders are connected to the form of playing, in order to teach the various individual game-action modes.

Problem:

- the designed teaching model is often far away from the goal of the game

Didactic principles in P.E. framework curricula at school

The didactic principles for sport game teaching at school usually laid down P.E. framework curricula are the following:

- Development of ability to play and versatile playing skills, to be acquired through spontaneous and creative play in various situation and the continuing development of playing competence with increased attention to technical aspects
- Development of awareness of rules as the ability to recognize agreements regarding the game and rules of the game, to change or redesign such rules as the situation requires, and to assume game leadership
- Being able to pursue tactical measures, take tactical decisions, and implement measures in the group and in the team.

Implementation of the EHF education plan into a didactical model for “Handball at School”: For the implementation of the EHF handball education plan as laid down in the 1997 EHF publication “The route to handball”, GUERRERO, GARCIA, OPPERMANN, NIELSSON GREEN, RINCK, HJORTH, SOLLBERGER and HÖRITSCH recommend an overarching master concept for teaching based on both an action-oriented and game-friendly didactic model of sport game introduction that is structured in three levels. It provides for the

acquisition of basic technical skills, but also trains coordinating abilities and promotes the development of general playing skills and social awareness in a teaching friendly environment.

- Level 1: “Me and the Ball” (“the ball, your playing companion”)
(carrying, bouncing, rolling throwing balls)
- Level 2: “With Each Other” (“me and my playfellow”)
(bouncing, passing, catching balls, co-operating, hitting)
- Level 3: “Against Each Other” (“team against team”)
(running loose, feinting, defending)

At all three levels, the child-appropriate (e.g. motion history) as well as game-appropriate (systematic development of basic play leading to target play) didactic concept is clearly apparent. The concept is thus ideally suited for acquiring general playing skills as well as, subsequently, specific skills for the sport game of handball, as the development of elementary, general skills as well as coordination and cognitive abilities is also of particular importance for the target sport of handball.

Components such as:

- Moving in space, moving without the ball (peripheral vision, “spacing” – orientation in space, running loose, breaking away, positioning oneself)
- Getting used to the ball (taking up the ball, carrying it, putting it down, rolling it)
- Basic technical elements (ball control – bouncing/dribbling, passing, catching/accepting, throwing/taking shots)
- Basic components of individual and group tactics (“give and go“/ passing – running loose and offering to catch, switching from offensive play to marking and vice versa, feinting, 2 against 1 player, playing together/co-operation, e.g.: double passing, changing position/crossing, screening/blocking, etc.)

should be practised in quickly changing situations, such as adaptation of equipment, number of players, size of court, rules or additional rules (e.g.: when touched by the opponent either a) pass or b) loss of ball, etc.) in playing and practice sessions.

University-level teaching and P.E. teacher further training courses

The following example, the course outline/programme for a one semester university course at the University Vienna Sports Science Institute in Austria, is focused on learning, practising and learning to teach sport-game-oriented movement sequences in handball:

The first third of the course is dedicated to the application of general ball-playing skills with special regard to specific components of the target game handball. The broad three-level master concept (Level 1 “Me and the Ball”; Level 2 “With Each Other”; Level 3 “Against Each Other”) is based on an action-oriented instructional model using sport-game didactics. Beside the acquisition and practice of technical fundamentals and coordinative abilities, it contributes to the development of tactical playing modes at the individual, group and team levels in playing and drill sessions held under changing situational conditions.

The remaining two-thirds are dedicated to teaching special playing skills in the target game of handball, i.e. handball basics, including technique and coordination (bouncing, passing, catching, passing variants, movement techniques, overarm shot, jump shot, falling jump shot, run-up, body feints, breakthrough, defence techniques, blocking, goalkeeper defence) as well as tactical skills (2:1 situation, passing the ball in motion, running towards the goal intending to take a shot, making space, running loose, marking, man-marking, space-marking).

At the same time, awareness and knowledge of rules are taught as well as general guidelines for educational game teaching. “Beach Handball” and “Street Handball” is presented in

theory and practice as alternative variant and trend sport activities, both out-and indoors, with a structure and philosophy differing from traditional handball.

The aim of the course is:

- to enable students to develop special playing skills in the sport game of handball, starting from a three-level action-oriented and game-friendly didactic model for sports games including “Me and the Ball”, “With Each Other” and “Against Each Other” modules as well as the practice of technical and tactical components.
- offer students an opportunity to get to know, by way of examples, key didactic concepts for sports and games as well as methods and didactical approaches for teaching special tactical playing moves at the individual, group and team levels. This should permit the students to teach pupils at different levels of skill in different situational conditions (in terms of space and materials) including the differently structured alternative option of Beach Handball.
- develop among students an adequate ability to demonstrate the basic modes of behaviour in sports and games as well as to train the ability of identifying faulty behaviour and suggesting improvements.

P.E. teaching competence shall comprise:

- Knowledge of key didactic concepts for sports and games as well as methods and didactic approaches for teaching proper handball conduct on the basis of a “minimum set of rules”, awareness of rules, and fair play,
- Ability to provide special education in sports and games matched to different levels of skills and conditions,
- Ability to demonstrate basic patterns of conduct in ball games in the target game of handball, fundamental mastering of key tactics at the individual and group levels.

Implementation in university education courses for P.E students shall contain:

- Alternation between practical implementation of didactic concepts for sport-games, specific teaching methods for skills and conduct during the game, and joint reflection on approaches with the students
- Independent preparation and execution of individual teaching units followed by critical reflection and feedback
- Combination with other courses in methodology, didactics, biomechanics and training theory
- Examination criteria

Conclusion:

To successfully promote the game of handball at school P.E. teachers have to be educated or provided with proper didactical tools and teaching aids, thus helping them to bridge the gap between the excellent methodology in handball literature and the daily practice of teaching handball in a gym or outdoors, whatever facilities they have at their disposal. That is why didactical concepts have to be implemented in university instruction of P.E. students as well as in further training courses of P.E. teachers at school. Future authors of handball methodological literature or documentations, using whatever kind of media, have to pay more attention to the aspect of transcribing their methodological content into a didactical language for the teacher (e.g. manuals) in order not to weaken the position of handball as a “school sport” for boys and girls. It has to be the task of the governing technical and political bodies of EHF and IHF to assist and support P.E. teachers in their efforts and motivation to promote “Handball at School” all over Europe and the world.

PSYCHOLOGICAL CHARACTERISTICS OF SLOVENE HANDBALL GOALKEEPERS

Tanja KAJTNA, Maja PORI, Igor JUSTIN, Primož PORI

Faculty of Sport, University of Ljubljana, Ljubljana, Slovenia

ABSTRACT

Handball is a fast, dynamic sport and the role of the goalkeeper is especially exposed, but little attention is paid to the development of the goalkeeper. We decided to focus our research in psychological characteristics of handball goalkeepers, specifically aggression, anxiety, reaction times, fluid intelligence and concentration. We compared more and less successful goalkeepers in those characteristics. We included 46 participants – 23 of them were more successful and 23 less successful, according to an expert evaluation. More successful goalkeepers were also significantly older. The data was collected in 2010 and 2011. The instruments used were Buss Durkee aggression questionnaire, Spielbereger's anxiety inventory (STAIX – 1 and 2), Test of series for measuring fluid intelligence, the Test of Attention for measuring concentration, and the CRD Series for measuring reaction times. One-Way ANOVA was used to compare both groups.

We found several significant differences between both groups – less successful goalkeepers have a faster simple reaction time and make fewer mistakes when reacting to simple stimuli and they are also quicker in response times to simple visual orientation stimuli; they also seem to lose less time when reacting to different stimuli. It thus seems that neither reaction times, fluid intelligence nor concentration or anxiety or aggression, influence the quality of handball players. The obtained result is easily explained with the age of the participants, since these are abilities, which gradually decrease over time.

Keywords: handball goalkeepers, aggression, anxiety, reaction times, fluid intelligence, attention

INTRODUCTION

Literature shows sparse information of what makes a good handball player from the psychological perspective and this research focuses on the psychological characteristics, which are important in the tasks the handball goalkeeper has to perform during the game. Physically we have some results, though few and often contradicting - they found that handball goalkeepers are slower runners than other handball players (Šporis, Vuleta, Vuleta, Jr. & Milanović, 2010), while Chaouachi, Brughelli, Levin, Boudhina, Cronin & Chamari (2009) found no differences in the same trait. Some research was focused on the morphological traits and found goalkeepers to be taller, heavier and have longer limbs (Srhoj, Marinović & Rogulj, 2002; Šentija, Matković, Vuleta, Tomljanović & Džaja, 1997; Gorostiaga, Granados, Ibanez & Izquierdo, 2005; Hasan, Rahaman, Cable & Reilly, 2007; Massuça & Fragoso 2011). Some studies found goalkeepers to have more body fat (Srhoj et al., 2002; Šporis et al., 2010; Šibila & Pori, 2009).

Fluid intelligence (as part of the g-factor) has a positive influence on perceptual abilities and the coordination of movement (Brochard, Dufour & Despres, 2004; Hughes & Franz, 2007). Higher fluid intelligence is seen in shorter complex reaction times in both children and adults

(Carmeli, Bar-Yossef, Ariav, Levy & Liebermann, 2008; Choudhury & Kathleen, 1999; Sonke, Van Boxtel, Geert, Griesel & Poortinga, 2008), it can also help control aggression (Richet & Richardson, 2008). Fluid intelligence has never been researched in handball players, but it has frequently been a part of research in musicians, where they showed that high level classical musicians have high fluid intelligence (Jakobson, Lewicky, Kilgour & Stoesz, 2008).

Anxiety can have a lot of impact on the success in sport – low levels of anxiety enable athletes to stay positive, calm and relaxed and enables the use of other psychological skills, for example imagery, positive thinking, good focus...(Dale, 2000; Hardy, Jones & Gould, 1996). Higher levels of anxiety and neuroticism affect a prolongation of selective reaction times and visual orientation tasks (Bunce, Handley & Gaines, 2008; Stelton & Ferraro, 2008). Several studies show a lower level of anxiety (both state and trait) with experienced and/or successful athletes or have learned to recognize their anxiety as helpful, rather than disturbing (Mellalieu, Neil & Hanton, 2006; Rokka, Mavridis, Bebetos & Mavridis, 2009; Spieler, Czech, Barry Joyner, Munkasy, Gentner & Long, 2007). Rogulj, Srhoj, Nazor, Srhoj & Čavala (2005) found no differences between female handball goalkeepers and players on other positions in anxiety, whilst we found no similar studies for male goalkeepers.

Top level athletes demonstrate a high level of psychoticism, which basically shows higher levels of aggression (Eysenck, 1981). It can be reflected in faster simple reaction times, but also lower precision in response (Vigil-Colet & Codorniu-Raga, 2004). Research from different sports shows that more experienced athletes are more aggressive (Bebetos, Christoforidis & Mantis, 2008; Christoforidis, Kalivas, Matsouka, Bebetos & Kambas, 2010; Konstantoulas, Bebetos & Michailideu, 2006) and the same was found for handball players (Christoforidis idr., 2010). Authors state that we should pay attention to different kinds of aggression and should always differentiate between positive, instrumental and reactive, destructive forms of aggression (Tušak & Tušak, 2003).

Perceptive abilities are important in team sports (Zwierko, 2007). Better and more experienced athletes are better in predicting the opponents' reactions, they anticipate better than non – athletes or less experienced athletes (Cañal-Bruland & Schmidt, 2009; Roca, Ford, McRobert & Mark Williams, 2011), shorter selective reaction times (Mori, Ohtani & Imanaka, 2002; Venter & Ferreira, 2004; Zwierko, 2007; Zwierko, Osinski, Lubinski, Czepita & Florkiewicz; 2010) and have shorter simple reaction times (Zwierko et al., 2010). Similarly, visual attention and concentration are extremely important in top sport, since they enable the development of specific visual search strategies, necessary for each sport and enable better prediction and anticipation (Morgan & Patterson, 2009). In many areas of life – professional, scientific and athletic as well as many others, people who were very skilled scored better in attention tests than those, who were beginners, which means that the use of attention can be well rehearsed (Allen, McGeorge, Pearson & Milne, 2004; Green & Bavelier, 2003).

The research so far has almost never specifically focused on psychological traits of male handball goalkeepers and it is the purpose of this research to estimate those traits in the group of successful handball goalkeepers in comparison with their less successful peers.

METHOD

Participants

46 Slovene handball goalkeepers participated in the research, they were divided into groups of better and worse goalkeepers according to the expert estimation of their quality, groups were equal in size, both containing 23 goalkeepers. The group of better goalkeepers was also older and more experienced, as can be seen from Table 1.

Table 1: Comparison of age and career duration of better and worse goalkeepers

	better goalkeepers		worse goalkeepers		<i>F</i>	<i>sig (F)</i>
	<i>M</i>	<i>SD</i>	<i>M</i>	<i>SD</i>		
age	24,30	4,55	21,96	4,25	3,27	0,08
career duration	14,57	4,28	10,96	4,42	7,91	0,01

Instruments

Test of series (*Test nizov* TN-10-A - Pogačnik, 1983) was used for measuring fluid intelligence. It consists of 30 series of tasks, whose difficulty increases. The task of the participant is to select one of the 5 suggested characters to correctly continue the series of characters. The time for the test is 10 minutes, which means that mental speed affects the results.

Attention was measured using the *Attention test* (Test pozornosti TP - Đurić, Bele-Potočnik & Hruševar-Bobek, 1985). It measures the participants ability to select, visually follow and detect the appropriate answer among the number of distracting elements. It consists of 40 rows of symbols, in each row the participant must count the number of predetermined symbols. The time is limited to 5 minutes.

Aggression questionnaire (Buss & Durkee, 1961) measured physical, verbal, indirect aggression, irritability, negativity, suspicion, hostility and the presence of feelings of guilt.

STAIX – 1 and STAIX – 2 (Spielberger, 1983) questionnaires were used to measure state and trait anxiety respectively. The first one measures the amount of anxiety experienced in a stressful situation (i.e. on a competition) and the second one measures the predisposition of a person to react with an intensified amount of stress.

Reaction times were measured using the CRD Drenovac machine (Drenovac, 1994 – simple reaction time was response to a single light appearing, complex reaction time was the coordinated response of hands and feet to a combination of lights, simple visual orientation task is also called simple selective response and consisted of finding the correct light amongst many possibilities (in accordance with instructions) and we also conducted a test of complex visual orientation where two correct lights had to be found on the basis of given instructions.

Procedure

The measurements were conducted in small groups for the tests of fluid intelligence, aggression, anxiety and concentration and the measurement of reaction times was conducted individually. All the measurements were conducted in laboratories at the Faculty of sport in Ljubljana in 2010. The success of a handball goalkeeper was estimated on the basis of an expert opinion.

RESULTS AND DISCUSSION

Table 2: Comparison of psychological traits of better and worse goalkeepers

		better goalkeepers		worse goalkeepers		<i>F</i>	<i>sig</i> (<i>F</i>)
		<i>M</i>	<i>SD</i>	<i>M</i>	<i>SD</i>		
Aggression	physical aggression	3,57	1,85	4,00	2,26	0,51	0,48
	indirect aggression	4,26	1,81	4,48	2,48	0,11	0,74
	irritability	4,35	2,39	4,65	2,39	0,19	0,67
	verbal aggression	7,09	1,50	6,43	1,97	1,59	0,21
	negativity	2,26	1,18	2,22	1,09	0,02	0,90
	hostility	2,30	1,33	2,09	1,50	0,27	0,61
	suspicion	3,52	1,88	3,39	1,95	0,05	0,82
	guilt	5,17	1,77	5,00	1,68	0,12	0,73
	anxiety - trait	33,57	5,07	34,43	6,47	0,26	0,61
	anxiety - state	35,61	6,54	35,61	7,10	0,00	1,00
	attention - correct answers	25,35	7,64	23,96	7,93	0,37	0,55
	attention - mistakes	5,17	6,67	3,96	5,10	0,48	0,49
	fluid intelligence - correct answers	21,83	3,60	22,52	3,37	0,46	0,50
	fluid intelligence - mistakes	4,78	3,09	5,48	3,00	0,60	0,44
Reaction times	simple reaction - total time	8,42	2,63	9,05	2,09	0,79	0,38
	simple reaction - mistakes	1,00	1,38	0,86	0,89	0,15	0,70
	simple reaction - time of mistake	1,15	1,21	2,41	2,43	4,89	0,03
	complex reaction - total time	29,89	5,40	27,94	7,19	1,08	0,30
	complex reaction - mistakes	10,71	4,31	9,95	9,58	0,11	0,74
	complex reaction - lost time	12,01	7,78	7,52	7,28	4,08	0,05
	simple visual orientation - total time	41,79	7,70	40,68	7,38	0,25	0,62
	simple visual orientation - fastest time	0,82	0,23	0,72	0,10	3,75	0,06
	simple visual orientation - mistakes	1,87	1,69	1,96	1,36	0,04	0,85
	complex visual orientation - total time	67,04	10,97	66,70	7,94	0,01	0,90
	complex visual orientation - mistakes	5,40	7,35	5,48	5,19	0,00	0,97
	complex visual orientation - lost time	19,77	13,91	12,80	11,68	3,39	0,07

Results show that there are some differences between more and less successful handball goalkeepers in their psychological traits. The differences all appear in the area of reaction times and all of them are in favour of less successful goalkeepers. When they make a mistake, they think about it longer, which indicates, that they are aware that something is not quite

right. They lose less time in deciding upon the correct answer in complex situations, they have faster response times in simple selection tasks and also lose less time in complex tasks, that require visual orientation.

Less successful goalkeepers were faster in synchronizing arm and leg movement, spent their time more rationally, which could be explained with the individual characteristics of the athletes (for example health status, body temperature, age, myelination of neurons, alertness...), which can affect the speed of response of an athlete (Jeromen, Barić & Kajtna, 2010). Less successful athletes were significantly younger than their more successful colleagues. Numerous studies have shown that younger participants have faster simple reaction times (Charness & Campbell, 1988; Geary & Wiley, 1991; Geary et al., 1993; Rogers & Fisk, 1991; Salthouse & Coon, 1994, all as cited in Salthouse, 2000), as well as faster complex reaction times (Horn & Masunanga, 2006). The other possible explanation would be that better (also older players with longer careers) have endured more injuries to the locomotory system, which could affect the functioning of the nervous system and the speed of the nervous – muscular reaction. It is known that health status and the myelination of neurons can affect the speed of response (Jeromen et al., 2010).

The next possible explanation could be that better goalkeepers were less motivated for the measurements and thus less successful – the younger and less successful goalkeepers might try to prove themselves more in an environment, which attempts to simulate the response in the game – responding to an appearing visual stimuli. Motivation, agility and attention increase the speed of reaction (Jeromen et al., 2010) and preparatory attention plays an important role, since it increases the level of activation and enables a faster response (LaBerge, 1995, as cited in Korošec, 2002). More successful goalkeepers should be more experienced tactically – tactical knowledge and experience have a great influence on success, equally to response times (Lipkova, Štulrajter, Norovskyjev in Miklanek, 1997) – in our case, it seems that perhaps the specific knowledge and tactical experience outweighed the reaction times, since not only were the groups equal, but even the less successful goalkeepers were better.

Both groups were equally efficient in selection and distraction avoidance tasks, which they faced in the test of attention – a similar finding was discovered by Memmert, Simons and Grimme (2009). No differences were found also in the testing of anxiety and aggression and fluid intelligence. Perhaps one of the reasons are the sample characteristics. Despite the fact that the sample was fairly large with respect to the entire population of Slovene handball goalkeepers, the very best ones were not available for testing, since they are playing abroad. That means that the goalkeepers participating in research were not really that different in quality, which of course would explain the lack of differences. It also raises the question of the expert evaluation of the quality – the problem was lack of useful statistical data on which to base the division into better or less successful goalkeepers. These are some issues that future research in the field should address – obtain results also from the best goalkeepers and look to some statistical data to help us divide the goalkeepers in both groups.

Tanja.Kajtna@fsp.uni-lj.si

ACUTE INJURIES IN HANDBALL

Patrick LUIG & Thomas HENKE

Ruhr-University Bochum, Bochum, Germany

Summary

Analysis of injury statistics and literature review indicates that the overall incidence of acute injuries in handball is around 2/1000h. Match incidences are ten times higher than training incidences. Lower extremities account for most injuries, followed by head injuries and injuries of the upper extremities. Sprains and contusions are leading injury types. Women are more vulnerable for non-contact lower extremity injuries whereas men have a higher share of contact head injuries. Backcourt players seem to be most at risk.

Keywords: *Handball, etiology, acute injuries, injury rates, injury situations*

Introduction

Not least because of its thrilling dynamics, handball has become one of the most popular team sports in Europe. Motion-analysis has shown that depending on playing-time and playing position handball players cover up to 6.5 km per game¹. Regarding these facts the necessity of a highly developed basic endurance in terms of pronounced aerobic capacities becomes obvious. In addition, athletes need to establish a proper athletic condition with regard to strength, agility, acceleration, deceleration, jumping and throwing power as the gameplay includes highly intermittent running with quick direction changes, frequent jumping and landing alongside with challenging technique elements like catching, throwing, passing and dribbling. Beside an intensive load for the locomotor and neuromuscular system this implies the need for a well-trained anaerobic metabolism in addition to succeed in the game. Even though less intense game phases and regular substitutions offer breaks for regeneration high-intensity phases during crunch time play that include repeated sprints up to 18 meters stress the anaerobic glycolytic metabolism¹. Moreover, rules and gameplay clearly implicate intended and unintended body contact. During frequent one-on-one situations players have to brave a high load of legal and illegal physical contact. One can conclude that the physiological and technical requirements in handball are pretty high, calling for perfectly prepared athletes. By implication, athletes with a bad athletic condition and limited techniques will be at greater risk for acute and chronic injuries. In fact, it is roughly estimated that in Europe at least 320,000 handball injuries occur each year at a cost for medical treatment of approx. € 250 to 400 million². The purpose of this paper is to display the basic aetiology of handball injuries as described in recent literature and supplemented by data from own surveys and injury databases and to conclude with potential key areas for injury prevention.

Definition of an injury

According to widely accepted consensus agreements a sports injury is defined as any physical complaint sustained by a player that results from a match or a training. Furthermore, if a player receives medical attention, injuries are referred to as “medical attention injury”, whereas an injury that causes a player to miss at least a full part in future training or match play is constituted as “time-loss injury”^{3,4}. Bahr⁵ points out that the time-loss definition is probably the most commonly used, as it at least covers the most relevant injuries. In addition, time-loss injuries are quite comprehensible, in particular when recorded retrospectively. If not mentioned specifically, the time-loss definition is applied for any injuries. Furthermore, there is generally a clear distinction between acute and chronic injuries. Corresponding to the above-cited consensus

documents an acute injury results from a specific, identifiable event whereas chronic injuries are caused by repeated micro-trauma without a unique identifiable event responsible for the injury. As these definitions were defined for football and rugby, both team sports with frequent contact between participating players, they may also be quite appropriate for handball. Although chronic injuries, in particular lower back pain, knee pain and shoulder pain in field players as well as elbow pain in goalkeeper, frequently occur among handball players overuse injuries are not so well recorded yet. Hospital records, insurance statistics or national surveys that are mainly used for data collection tend to focus on acute injuries⁶. Thus, this paper exclusively deals with acute injuries.

Methods:

Structured literature & database research

Pubmed, BiSp, SportDiscus and Google were browsed for relevant articles. Additionally, reference lists of retrieved articles were browsed for further information.

Surveys on sports injuries in handball

The Department of Sports Medicine of the Ruhr-University Bochum owns datasets on sports injuries, which have been built up in the framework of research projects in collaboration with the ARAG Sports Insurance (Dusseldorf, Germany) and the VBG (Hamburg, Germany). These datasets contain:

1. Data from a continuous survey among German sports clubs. Athletes, who report an injury, receive a questionnaire asking for details of the accident, injury onset and its treatment. In addition, information on sports activities (club sports and recreational sports) and general information on surveyed athletes is collected (total $n \approx 180,000$, handball $n \approx 25,000$).
2. Data from a survey among German professional handball players, who have been analysed during one single season by means of a purpose-designed questionnaire ($n=293$) complemented by basic data of all injured players ($n=1,636$). This questionnaire contained 36 questions and provided detailed information about:
 - detailed circumstances of the injury
 - position on the field
 - the injury itself e.g. injured body part, kind of injury, treatment
 - sports career und personal background e.g. number of games,
 - former injuries
 - sociodemographic and anthropometrical parameters e.g. height, weight, age.

Results:

Injury incidence / Injury rate

Acute injury incidence rates in handball are comparable to those in other team sports where one-on-one situations with inevitable body contact frequently occur, such as in football, field hockey or in basketball. Research indicates that the overall incidence is at about 1.5 – 2.0 injuries per 1000 hours of exposure. Although one should consider minor methodical distinctions in calculating training and match exposures, there is a general consensus that match incidences (8.3 - 46.5 injuries/1000h) are at least ten times higher than training incidences (0.6 - 3.4 injuries/1000h). It is striking that professional athletes show notable higher incidences than semi-professionals or amateurs. It cannot be proved beyond doubts if sex plays a decisive role regarding overall incidences even though it is absolutely clear that women are significantly more vulnerable to specific injuries than men. At least Henke et al. (2005)⁷ indicate higher overall incidences – in training and match – for male professionals compared to elite female athletes (cf. Tab.1).

Tab. 1. Time-loss injury incidences; *studies on professionals only; ** calculated

Study		Training (injury/1000 h)		Match (injury/1000 h)	
		Male	Female	Male	Female
Wedderkopp et al.	1997		3.4		40.7
Seil et al.	1998	0.6		14.3	
Wedderkopp et al.	1999		1.2		23.4
Petersen et al.	2002	2.6		12.1	
Olsen et al.	2006	0.6	1	8.3	10.4
Henke et al.*	2005	0.7	0.2	46.5	8.9
Junge et al.*	2005			40	36
Langevoort et al.*	2007			34	19
Holdhaus et al.*	2008			33.3**	
Holdhaus et al.*	2009				31.9**

Generally speaking, about 2/3 of all injuries occur in competition and 1/3 during training. As table 2 shows, injuries in competition gain more significance with advanced age and performance level, even though more time is being spent in training compared to time spent in competition.

Tab. 2. Share of match and training injuries in % with regard to age and gender (n = 5,689)

Age	<14 years		15-21 years		22-35 years		professionals	
	male (n=515)	female (n=502)	male (n=1,207)	female (n=835)	male (n=1,531)	female (n=801)	male (n=224)	female (n=74)
Match	49.1	53.6	64.2	66.7	73.7	73.5	85.0	74.0
Training	50.9	46.4	35.8	33.3	26.3	26.5	15.0	26.0

With respect to specific injuries some studies reveal, that in particular knee injuries seem to have a plainly higher match incidence compared to training. Regarding men, Myklebust et al. (1998, 2003)^{8,9} report an 8 times higher match incidence which is even topped by a 53 to 93 times higher match incidence among women.

Injury topography / Anatomical location

The analysis of 8,520 handball injuries among 14 to 45 year old athletes revealed that handball injuries can essentially be attributed to four main body regions: Regarding the upper body head (male: 17.4%; female 13.2%) and hand/wrist (male: 19.8%, female 19.6%) are considerable core regions, whereas when talking about the lower extremities knee (male: 23.0%; female 31.7%) and ankle joints (male: 18.6%; female 22.1%) are mainly affected. In general female athletes have higher shares of knee and ankle injuries, whilst among male athletes the head is more frequently injured (cf. Fig. 1.)

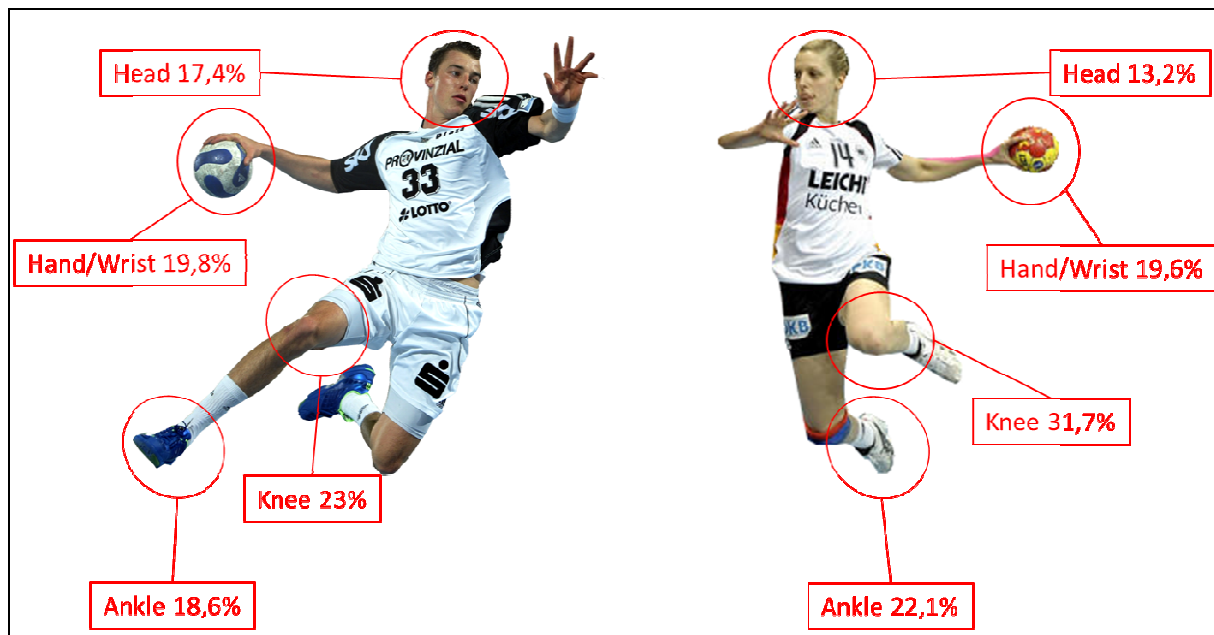

Fig. 1. Localisation of acute injuries among male and female athletes (n=8,520, 14-45 years)

Going more into details, younger athletes seem to be more prone to injuries of the upper body regions, especially finger injuries. With advancing age there is an increase in injuries of the lower extremities, in particular in knee injuries. Almost half of all injuries in the group of players under 14 years of age relate to hand/wrist or head. In contrast nearly one third of all injuries in adults relate to knee injuries. In female professionals even every second injury is a knee injury (cf. Tab. 4).

Tab.4. Localisation of match injuries in % with regard to age and gender (n = 3,777)

	<14 years		15-21 years		22-35 years		professionals	
	male (n=249)	female (n=266)	male (n=759)	female (n=550)	male (n=1,121)	female (n=588)	male (n=190)	female (n=54)
Head/Neck	18.5	11.9	18.6	16.9	18.4	16.3	10.3	7.5
Trunk	2.8	1.1	1.7	1.4	1.9	1.2	-	-
Shoulder	2.4	1.5	7.1	4.1	8.2	2.7	-	-
Arm	12.3	4.8	3.1	1.0	0.6	0.9	-	-
Elbow	3.6	2.6	1.9	2.3	0.9	1.2	-	-
Hand/Wrist	27.6	33.9	19.2	15.4	18.7	19.5	14.1	13.2
Hip	-	0.7	1.2	0.9	0.3	0.3	-	-
Thigh	0.4	-	0.8	-	1.3	0.7	-	-
Knee	9.5	12.3	24.4	35.2	28.2	34.1	24.9	49.1
Lower leg	2.0	1.1	2.1	1.1	7.6	5.1	-	-
Ankle	15.8	27.9	16.6	19.7	11.5	16.8	18.9	17.0
Foot	4.0	1.1	1.4	0.5	1.7	1.0	-	-

Recent studies show similar tendencies. There is a general consensus that regardless from age, gender and performance level the majority of all injuries affects the lower limbs^{10,11,12,13,17}. Moreover, is obvious that young female athletes have a significantly higher risk to sustain a severe knee injuries^{8,14,15,16}.

Injury types

The most common acute injuries are sprains, with knee, ankle and fingers being the most affected body parts followed by contusions and strains^{11,17,18,20}. Fractures and dislocations are quite rare. However, younger athletes are typically more vulnerable to fractures, in particular finger, wrist and forearm fractures, than older athletes. Strikingly, during important elite tournaments contusions become more frequent^{21,22,23,34}.

Injury situations & risk factors

Studies commonly differentiate between contact situations, whether legal contact or foul play, and non-contact situations, typically running with quick direction changes, cutting and pivoting, starts and stops as well as jumping and landing on one or both feet. On closer examination of 293 injuries in German professional handball contact situations, either with an opponent or a team-mate, trigger injuries most frequently, followed by jumping, landing, and running with quick direction changes (feints), which are typical non-contact injury situations (cf. Fig. 2.). In the majority of all cases injuries occurring in contact situations affect the upper body, in particular head and fingers. In contrast, non-contact injuries mostly are related to the lower extremities

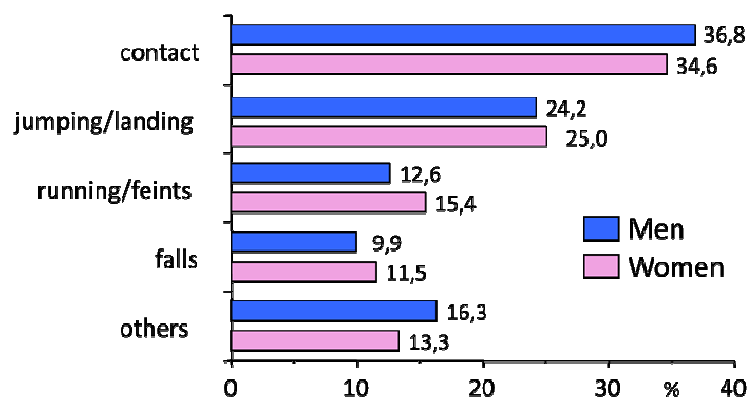

Fig.2. Situations leading to injuries (in %) among elite athletes (n=293)

Seil et al. (1998)¹⁷ report 53% of match injuries that are due to contact with opponents whilst in training only 19% of injuries derive from contact situations. The share of contact injuries is even higher during major international tournaments (71-92%). Except from 2008 Men's European Championships in Norway at least half of these injuries are caused by foul play – independently from gender^{21,22,23,24}. Several studies have indicated that female particularly young female athletes are at greater risk for non-contact injuries. This is insofar of great significance as non-contact injuries are commonly more serious than contact injuries. Almost 90% of ACL ruptures are reported to happen without the opponent's or team-mate's contribution^{8,9,14}. In general players in offensive actions are more at risk than defence players^{19,20}. Our data show that attacking backcourt players are mostly affected by injuries, followed by attacking pivot players and central defenders. Strikingly, pivot players have the highest share of head injuries. Among female athletes Froböse et al.(1996)²⁰ state a 30% higher injury risk for pivot and backcourt players compared to other playing positions. Some other studies also demonstrated that backcourt players have the highest overall incidences, in particular with regard to non-contact injuries of the lower extremities^{8,9,11,16}. Our data and recent research states that previous injuries increase the risk for recurring injuries, in particular with regard to injuries of the lower extremities^{11,25}. Among these ankle injuries are most common to reoccur. Moreover, Olsen et al. (2003)²⁶ indicated a correlation between playing surface and injury risk. According to them artificial floors have a higher friction compared to wooden floors and thus can increase the ACL injury risk for women.

Conclusions:

Handball is a physical and dynamic contact sport with a noticeable injury risk, in particular during matches. Even though the highest share of injuries is due to contact, in particular those severe non-contact injuries seem to be a key area for targeted injury prevention.

Contact injuries are most commonly less severe (i.e. minor contusions) compared to non-contact injuries. It has to be discussed if contact injuries, especially those that cannot be attributed to unfair play, are somehow evitable. Passive protection such as mouth guards and prophylactic finger tapes can probably assist to reduce the incidences of minor contact injuries such as finger sprains and soft tissue injuries. Certainly, in case of previous injuries, the wearing of protective devices, for example the application of external ankle stabilization such as tape and ankle braces, is explicitly recommended.

However, research and practice have revealed good opportunities to tackle the more serious non-contact injuries. Generally speaking, the various facets of training and physical preparation such as functional strengthening, core stabilization, agility training, neuromuscular and proprioceptive training can contribute to the reduction of injuries, if applied regularly and correctly. This includes technique training for crucial handball movement patterns that typically lead to match injuries e.g. jump shots, single-leg landings and feints. The discrepancy between training and match injuries shows up that even today, athletes are still not that good prepared for the demands of competitive gameplay.

Federations, clubs and coaches are certainly in charge to protect their athletes best possible. This also includes sufficient preparation and regeneration, especially prior to and after major international events in professional handball.

Moreover, reinforcing the coaches' education could be a promising approach to promote available know-how on handball injuries and how to prevent them.

Despite increasing efforts to propel this issue, the handball community is still not fully aware of the potential of smart injury prevention, which as a positive side-effect can also improve the individual performance of athletes – a win-win-situation for all.

Acknowledgement:

Parts of this publication derive from the European project “Safety in Sports” which has received funding from the EU, in the framework of the Public Health Programme 2003-2008.

patrick.luig@safetyinsports.eu

INJURY PREVENTION IN HANDBALL

Patrick LUIG & Thomas HENKE

Ruhr-University Bochum, Bochum, Germany

Summary:

Literature search identified 109 recommendations in four key categories related to preventing handball injuries. An expert panel (n=11) assessed the value of these 109 recommendations to expose the most promising ones, which were then pilot tested in two national federations. As a result of this process general recommendations on how to prevent handball injuries are given. Moreover, smart ways of promoting injury prevention in the handball community are depicted.

Introduction:

Injury statistics and literature reviews indicate an overall incidence of 1.5 – 2.0 acute injuries per 1000 hours of handball exposure. As two million EU citizens regularly play handball this leads to a conservatively estimated number of 320,000 injuries each year at a cost for medical treatment of approximately € 250 to 400 million¹. Despite injuries being an apparent problem in the handball community, injury prevention still seems far away from being a high-priority issue. The fact that a sports injury is mainly a consequence of definable risk factors is not common knowledge. Still a large share of the athletes, coaches and functionaries sees bad luck as main cause for getting injured. The relation between certain risk factors and increased injury rates has not fully reached public awareness. Moreover, prevention is frequently seen as therapeutic intervention that needs extra efforts in terms of time, material and personnel. It is not so much the knowledge how to prevent injuries that fails, but the challenges are in particular to get these measures being accepted. To propel injury prevention in handball in the long term it is of vital importance to increase the perception of sports injuries as more or less predictable and preventable incident and to promote preventive measures as contributions to individual and team performance enhancement. Thus, successful and sustainable sports injury prevention has to be effective, applicable and acceptable at once. The purpose of this paper is to show up smart ways how to prevent handball injuries in a sustainable manner.

Methods:

(a) Database & Literature Search¹

The authors independently performed a structured database and literature search for relevant publications. As of September 2009, PubMed, the Cochrane library, SportDiscus, BISP-databases and EMIP were browsed, using multiple combinations of the keywords INJUR*, PREVENT* and HANDBALL. In addition to the database research a multi-lingual web search using the internet search engine Google.com was conducted. Following these two initial literature searches, the reference lists of the retrieved articles were browsed for further information. Additionally, available authors and co-authors were contacted for complementing the findings with articles from their personal archives. After full-text review and exclusion of non-fitting articles the compiled publication list consisted of 75 publications with 109 single recommendations related to preventing injuries in handball. A subdivision of the identified recommendations into four more or less distinctive categories became obvious:

- Training & Physical Preparation,
- Technical & Political Approaches,
- Equipment & Facilities, and
- Medical & Non-medical Support

More than one third of the published recommendations were based on strong scientific evidence, all others were at least based on expert opinion and have been practiced in handball (cf. tab. 1).

Tab.1. *Distribution of preventive recommendations depending on category and validation level*

Validation level	Training & Physical Preparation	Technical & Political Approaches	Equipment & Facilities	Medical & Non-medical Support	
Multiple scientific validation	16	2	5	1	24 (22%)
Single scientific validation	13	0	1	2	16 (15%)
Science-based	14	7	5	0	26 (24%)
Multiple expert recommendation	13	6	5	1	25 (23%)
Single expert recommendation	9	3	4	2	18 (16%)
	65 (60%)	18 (17%)	20 (18%)	6 (5%)	109

(b) Consensus Building²:

In order to better assess the value of these 109 recommendations, experts in the field of handball injury prevention were invited to join an expert panel (N=11) that reviewed each of the presented preventive recommendation on three criteria:

→ **potential EFFECTIVENESS** in terms of reducing injuries (i.e. injuries become less frequent or less severe)

→ **potential APPLICABILITY** in terms of required effort for realisation (i.e. low time, financial, material and personnel expenditures)

→ **potential ACCEPTANCE** within the handball community (i.e. execution in compliance with athletes, coaches and associations)

As a result of this consensus-based evaluation process a list, ranking recommendations from very promising to unpromising, was generated. This ranking clearly revealed, that the area “Training & Physical Preparation” does not only offer the most (60%) but – with regard to the expert assessment – also the best opportunities to take measures against handball injuries.

(c) Test implementation³:

The results of the literature search and the experts’ consensus led to a proposal of very promising preventive approaches. This so-called “Prevention Toolbox”, at least selected parts of it, was destined to become test implemented in two collaborating national handball federations (i.e. Czech and Norwegian Handball Federation). As an advanced step of systematic consensus-building, multiple meetings with experts and persons in charge from both pilot federations and from the EHF were hold to tailor the implementation according to respective national demands, capacities and requirements. As the main area “Training & Physical Preparation” is an explicit remit of handball coaches both federations identified coaches as key target group for the implementation. They embody the link between theoretical knowledge and practical application. The integration of injury prevention – if not integral part so far – into the regular national coaches’ education or a review and update of the respective education sector was aspired as main aim. Theoretical and practical seminars were developed and hold on multiple occasions during the span of the implementation period. A critical reflection of the test implementation led to a refinement of the original “Prevention Toolbox” according to experienced deficits. Moreover, instructors were educated and curricula were established or adapted to guarantee sustainability.

Results:

The following general recommendations are basic results of the applied methodical process:

(1) Training & Physical Preparation*Basic Physical Preparation*

Dynamics in handball have significantly increased. To meet the demands of the current game play and furthermore to prevent injuries due to fatigue, insufficient regeneration or athletic mismatching, players of all levels and ages need a proper basic athletic condition with regard to endurance, strength, flexibility and speed. On competitive level this is primarily achieved through structured and supervised athletic conditioning programmes that include individually adapted endurance training, functional weight training, dynamic mobilization and agility drills. Key period for basic physical preparation is during preseason but to stay physically in shape season attending programmes are clearly recommended. Athletes in bad athletic condition are significantly more vulnerable for acute injuries and in particular for developing overuse symptoms like jumper's knee, low back pain and shoulder pain.

Structured Warm-up Routines

General cardiovascular activation for 10-20 minutes prior to handball sessions is essential. This is common knowledge. However, warm-up sessions are still in great need of improvement as they are perfectly suited for implementing preventive training contents. Beside basic running drills it is strongly recommended to apply neuromuscular, proprioceptive and balance exercises as well as core stabilization and coordination practices. Additionally, plyometrics and agility drills should be included at the end of warming up. Basic handball movement patterns that are linked to increased injury risks can be trained perfectly during warm-ups. This means adding technique exercises that are designed to improve knee and ankle control during jumping, landing and cutting activities. The big advantages of structured warm-up sessions that include the above mentioned elements are, first, that you do not need to spend lots of extra time on preventive training. Second, warm-up is a regular routine in training and competition and all the aforesaid elements need regularity to have a preventive effect.

Basic and Advanced Technique Training

Handball includes crucial movement patterns that, on the one hand, are of highest importance for the athlete's game performance. On the other hand, they also bear an increased injury risk. Main idea behind technique training is to improve player's performance in typical handball elements. Good jumping capability is essential for shooting and blocking. Quick feet are needed for feints, direction changes, turns, starts and stops in defense and offense. Good ball handling helps you passing, catching, dribbling and stealing. However, technique training is also needed to perform these tasks safer because these techniques also bear an increased injury risk. Proper jumping and landing technique in terms of knee and ankle control help athletes to sustain crucial situations like single-leg landings. Correct ball handling is an important factor to prevent numerous finger sprains and quick and controlled feet assist in coping pivoting movements. Technique training, if already applied starting with young ages, combines performance enhancement and aspects of injury prevention. Athletes and coaches should be aware of the correct techniques and potential consequences of insufficient technique training. With increasing age and performance level technique training should be adapted to the advanced demands of the athletes. This means for example, progressively adding controlled perturbations (contact) during execution of these movement patterns. Intense physical contact is inherent element of handball and players should get used to it in training to cope with it during competition. Basically, this also helps athletes performing better e.g. better scoring efficiency during contested jump shots (e.g. wing shots, breakthrough shots)

Neuromuscular Training

There is clear scientific evidence that neuromuscular training by means of proprioceptive balance training contributes to the reduction of injuries of the lower limbs. Exercises on unstable devices such as wobble boards, slings or mats in combination with core stabilization and plyometrics are helpful when conducted regularly (at least 1-2 times per week) during preseason and season. Neuromuscular training contents can be perfectly integrated into warm-up routines, in particular with regard to the fact that this kind of training has bigger effects in non-fatigued athletes.

(2) Technical and Political Approaches

Injury Surveillance

Injuries should be systematically recorded at club and national level, in order to identify individual and situational risk factors, to monitor injury trends and, moreover, to evaluate effects of applied prevention measures.

Increase of Awareness

The awareness of the injury problem and the perception of prevention as a positive contribution to sports performance is a key issue. Individual athletes and coaches on the handball floors, and moreover, clubs and federations on policy level are main target groups for detailed information on handball-specific injuries, risk factors, injury situations and mechanisms as well as solid knowledge on effective, applicable and acceptable countermeasures.

Adaptation of the Education Framework

Athletes and in particular coaches should receive at least a basic education in handball injury prevention. Injury prevention should be integral part of the regular education framework.

Reduction of Matches / Regeneration

Match incidences are significantly higher compared to training incidences. On professional level, a revision of the competition schedule could help to shrink the dramatic number of injuries during and immediately after international competitions. At least a better arrangement of national and international competitions is desirable. Sufficient regeneration will reduce overuse symptoms and acute injuries due to fatigue or inadequate cured disorders.

(3) Equipment & Facilities

Mouth Guards

There is a certain risk for dental and orofacial injuries. When occurring they are mostly of severe nature. It is therefore strongly recommended that handball players, in particular pivot and backcourt players should wear custom-made mouth guards.

External Ankle Support

It is evident that ankle sprains are at least partially preventable when athletes use ankle braces, orthoses or taping as external protection. Especially, players with a history of ankle injuries should be advised to use external ankle support to prevent recurring injuries.

(4) Medical & Non-medical Support

Pre-Season Screenings

At least for professional athletes it is recommended to have regular pre-season screenings to detect potential risk factors for injuries or damages e.g. cardiovascular diseases, muscular imbalances, athletic and neuromuscular deficits.

Performance Diagnostics

Performance diagnostics that identify the athletes' individual needs for improvement can assist in increasing physical condition and general performance and thus contribute to reducing acute and chronic injuries. A supervision of the athlete by athletic coaches and/or physiotherapists is seen as beneficial.

Conclusions:

The above-mentioned recommendation can be seen as a first state-of-the-art consensus on preventing handball injuries. With respect to the process they have run through, one can conclude that the provided recommendations have solid proof to be effective in preventing injuries, they are applicable in the respective sports setting (federations, clubs) without huge extra efforts, and they have shown to find favor (acceptance) within the handball community, which is a very important aspect for the maintenance and sustainability of applied injury prevention.

However, research and practice have shown that it is not so much the knowledge how to prevent injuries that fails, but the challenges are in particular to get these measures being accepted. Therefore, it is essential to identify appropriate ways how to promote the information within the handball community. Beside a consensus on very promising prevention measures the test implementation in two pilot handball federations have also revealed easy and smart ways of promoting these contents. The following promotion strategies allowed a smooth implementation in Czech and Norwegian handball and may therefore also serve as good examples for future work in other federations.

Information

Handball associations and clubs should follow a pro-active strategy as to increasing the awareness of handball injuries and communicate with members (e.g. instructors, coaches, clubs, athletes) and the general public openly about risks involved and necessary measures to be taken by clubs and individuals. Coaches and athletes should be provided with information brochures and video productions presenting basic exercises, which should be for instance available for downloading from the EHF's Website and national websites. Such a pro-active approach will contribute to the positive image of the game and the organisations involved, and will help to attract new members.

Education

It is recommended to have all national associations to include an injury prevention module in their trainer education curriculums and to designate an official staff member as 'safety promotion ambassador' of the federation. Considering the education two different modules should be regarded. Firstly, it is possible to implement a module which is directly addressed to the coaches. Moreover, there might be an advanced coach instructors' course, which allows reaching larger populations. Both modules should contain theoretical and practical elements. Furthermore, integration into coaches' certification of all levels and license renewal is desirable.

Injury Prevention is Performance Enhancement

As the primary goal of sportsmen and women is to maximise their performance, preventive measures can best be integrated as core components in sport-specific performance enhancement programmes. This will increase the chances of successful and sustainable injury prevention in training and coaching.

Acknowledgement:

This article is part of the European project "Safety in Sports" which has received funding from the EU, in the framework of the Public Health Programme 2003-2008.

patrick.luig@safetyinsports.eu

WHAT'S THE DIFFERENCE? – COACHING FEMALE AND MALE HANDBALL PLAYERS

Zoltán MARCZINKA

Semmelweis University, Faculty of Physical Education and Sports Sciences Budapest, Hungary

In today's society, there is parity between the sexes. In handball, the rules and competition schedule are the same for both men and women, so too is the technical and tactical repertoire required of the two genders. It is logical then, to assume that men and women teams are prepared in the same manner. However, experience has proven that due to the anthropometrical, hormonal, psychological, social, emotional and sexual differences developed through evolution, female and male players (thus men and women's teams) require different approaches from the coach.

I have been fortunate to have worked with both genders at both national and club level. In my article, I collate and summarise the differences between the two genders by looking at four major aspects of training.

- **PHYSICAL ABILITIES** - differences in: strength, agility, endurance, flexibility, body mass, proportion of muscle and fat, proportion of trunk and limbs
- **CO-ORDINATIONAL ABILITIES** - differences in: special awareness, eye/limb and eye/ball coordination, movement coordination
- **COGNITIVE ABILITIES** - differences in: thought processes, visual perception, oral ability, communication skill, learning style, personality
- **EMOTIONAL FACTORS** - differences in: social relationships, behaviour on and off court, emotional life, pain threshold, mood swings

Differences in PHYSICAL ABILITIES

The most obvious differences between men and women are the anthropometrical features. Men tend to be on average 10 – 12 cm taller than women and their body mass is also heavier with an average of 10 – 13 kg heavier. Consequently, men's upper and lower limbs also tend to be on average 5 cm longer than those of women. The circumference of their chest, arms, legs and hands are also larger. Furthermore, women tend to have longer trunks and shorter limbs in comparison to their male counterparts. When we look at the differences in muscle mass, it is obvious that in men it is proportionally larger than in women. This is why men's body shape is more robust and linear while women have a softer, curvier line. By comparison, the proportion of body fat in women is generally higher (28 – 32%) while that of men is lower and can fluctuate within a greater range (18 – 42%). Another difference is that women seem to have a lower bone mineral content which means a looser weave while men have a tighter weave due to a higher bone mineral content.

These anthropometrical differences should be taken into consideration primarily during condition training.

Strength - The level of testosterone is a decisive factor in relation to strength training. Men produce between 2.5 - 11mg per day while women produce on average 0.1mg per day. As a result, men will always have an anatomical advantage over women, as they are able to develop greater muscle power. Since by nature women can only develop up to 2/3 the power of men, it is obvious that when planning condition training, their workload needs to be proportionately reduced to that of men. Particularly when programming weight exercises, the workload of

women should be 20-25 % less than that of men. As a consequence of more muscle strength, men are faster.

The difference in the proportion of body parts must also be taken into consideration. That is, men generally have shorter trunks and longer limbs, thus longer leverage. While women tend to have longer trunks and shorter limbs, thus shorter leverage. Therefore, because of the longer trunk, special attention needs to be taken in developing core stability in women and strengthening the muscles along the spine.

- *In my experience male handball players prefer exercises which either highlight their masculinity (biceps, pectorals) or which give them an opportunity to compete and rank against each other (bench presses, chin ups). Women players instead, avoid weight - training machines if they can and prefer exercises (stomach, back and butt) which help to improve their figures (body shaping).*

Endurance - Another factor that needs to be taken into account is that the relative VO₂ max between women (50-55 ml/kg/sec) and men (60-65 ml/kg/sec) is different. Consequently, when setting up an endurance training program for women the target should be approximately 10% less than that of the men.

- *In endurance training, in order to burn fat, women players prefer medium and long distance running in a group and outdoors. Men players instead dislike the monotonous group runs and tend to cut them short when there is no supervision. They better enjoy sprints and short distance running where they can display their competitive spirit and dominancy.*

Flexibility - Due to puberty, the testosterone level in boys' blood suddenly increases. Hence, after 12-13 years of age, flexibility in boys reduces and they need twice as much stretching as girls after this phase. Without special stretching exercises the flexibility of girls also reduces, but not to the same extent as boys.

- *As a result of the aforementioned differences regarding flexibility, women players don't need constant reminders from the coach to do warm up or cool down stretching. In men's, teams the lack of motivation can be compensated by including stretching exercises into the training or to do the stretching in a group formation.*

Differences in CO-ORDINATIONAL ABILITIES

Spatial vision and awareness - Due to the differences in the brain function of men and women, the part of brain that is responsible for understanding connections in space (lower cortex) is larger in man. Consequently, spatial vision, spatial awareness, mathematical and logical thinking ability is better developed in men. This is why men can better handle certain patterns, shapes, abstract connections and can read maps with relative ease. Women on the other hand are better in quickly identifying missing parts, thus better in mosaic games.

- *During time-out, men players are able to follow coaching instructions without visual demonstration and they are able to read the tactical board upside down. However, women players need colourful, visual stimulation, a well detailed explanation and, they also need to look at the tactical board right side up.*

Movement co-ordination – Historically speaking, man the hunter was forced to perfect the skill of following and hitting a moving target. Therefore, eye/limb and eye/ball coordination in men is more developed and this explains why they are better skilled in ball games and learn new ball-related technical elements faster than women do.

- *This difference needs to be taken into consideration when teaching technical elements: men players are often able to copy the new movement in full (global teaching method) while for women's teams generally, the movement has to be broken down into segments (partial teaching method).*

Differences in COGNITIVE ABILITIES

Thought processes - During evolution, the brain of the two sexes developed differently according to their specific functions in society. Men were the hunters and protectors whereas women were the gatherers and nurturers. According to these roles, their bodies and minds adapted to these tasks and have continued to do so over millions of years.

When we look at the brain specifically, the differences are obvious. For example, the left half of the man's brain is more divided and more detailed than the right side. This is why there are more cases of the two extremes of intelligence - genius or retarded. Women, on the other hand, have better connections between the two halves making the woman's brain more flexible. That is, one side of the brain can take on the tasks of the other side when and if necessary. In summary, man's thought process is structured and organised while woman's is convoluted in detail.

- *Therefore, a coach can set a long term goal for a men's team as they will stay focused on the target, working towards it one step at a time. It is more difficult for a women's team to stay on track for a long period of time as they get sidestepped easily. Rather it is better to work towards a final goal with small rewards along the way.*

Visual perception – During evolution, visual perception developed differently in men and women because their roles required different needs. As woman's role was to gather small items, protect the children and keep the home fires burning, she had to be able to monitor what was going on around her. This is why women have good peripheral vision, seem to notice what is happening around them and are better able to divide their attention and multitask. Men however, were hunters, warriors and food providers and so needed better tunnel vision. This explains why they are better able to pinpoint a target and have a better sense of depth and distance and also why they focus on only one task at a time.

- *Women players better see the playing court in its full spectrum and the centre back is often able to pass the ball to the winger without looking at her. Men instead are more accurate in shooting exercises and courtesy of their more developed vision in depth, judge the shooting power and passing distance better.*

Verbal ability - The frontal lobe of the woman's brain, which is responsible for speech, is significantly bigger than the man's. Consequently, women's oral and verbal skills are better developed, they learn languages easier, use the mother tongue better, and talk approximately three times as much as men. Women can also spell out the "big words" easier than men.

- *Coaches need to accept that women's teams are generally chattier and louder than men's. They require occasion to socialise and chat - if there isn't any they create one. Men's teams don't mind to sit around in small groups either, but they need a purpose to do so and they find regular team functions a burden.*

Communication skills - There are also differences between the two sexes in how they pass on information. A woman's brain senses hearing on both sides of the brain, while only the left side of the man's brain does this task. Therefore, men tell the substance of the situation, focusing on the important aspects while women can concentrate on details as well.

- *In handball, this difference needs to be particularly considered in game analysis and when giving tactical instructions. For women players, how the information is presented (choice of words, body language and tone of voice) is very important. While in men's teams, visual input often works better as a way of communication.*

Learning style - Men can better rationalise an abstract thought and integrate it than women, therefore they learn tactical elements and set moves faster and can apply them by approximately 1/3 times more effectiveness than women in a competition situation. Women's teams however, need twice as much time to learn the same choreography. It is often noticeable at trainings that at both the learning and application phases of set moves, men tend to add variations to a given program. Experience shows that male handball players consequently, tend to be more confident

and adventurous. While women on the other hand, will follow a given program to the letter. Thus, they tend to adhere closely to the set patterns and are less adventurous.

- *In my experience, women's teams prefer to play pre-trained tactical moves, where they – as individuals - can “hide” behind the team's work. Whereas men players don't like restriction and due to their more developed creativity they often improvise when there is a set move played.*

Environmental influences - Due to the different roles developed during the evolution of the two genders, women are more susceptible to the input of the outside world. In general, they worry more about their surroundings.

- *For women handball players for example the training and playing environment such as training facilities, change rooms, cleanliness and space are more important than for men. They have to feel comfortable and they need more time to prepare than men do.*

Personality - The differences in the way their brains work, determines the personality of both genders. Women are more open, make social connections faster and are more likely to look for contact and company. That is, they are more extroverted. Men are more insular. They try to solve problems on their own; they turn inside for answers and solutions and camouflage their emotions more so than women. They are more introverted.

Women and men judge success and ambition differently. Hierarchy and domination are important for men while women instead are interested in the type and meaning of the chosen task.

- *This difference has importance particularly in the early phase of team building: men players move about, observing and not mixing that easily at the beginning. Women players instead, because of their inborn curiosity, connect quickly, gather information about each other and form an opinion almost immediately.*

Differences in EMOTIONAL FACTORS

Social relationships - The genetic differences determine social relations of the two genders.

Men by nature are more egocentric and strive for dominancy. Therefore, in the hierarchy the fight for leadership is more evident in men's teams. Women on the other hand are more sociable; when making friends, sympathy and empathy are more important for them.

- *This difference is particularly noticeable during training when players have to choose teams. Men choose according to the hierarchy, keeping an eye on who can make their team stronger, while women choose team mates based on sympathy, friendship and loyalty.*

Leadership role – According to experience, not only in handball but also in team sports generally, the role of leadership has a different meaning for the two sexes. In girls' teams - before and after adolescence - social connections decide who is going to be the leader. In boys' teams - until puberty - undoubtedly the strongest of the pack, often an early developer, will be the leader. After the change, around 16 – 17 years of age, physical differences become less obvious and so “strength united with brain” will be the main criteria for choosing a leader.

- *It is important that the coach know that inside fighting and striving for dominancy are natural and necessary elements of team life. Therefore, in men's teams in particular, it is advisable for the coach to observe and control but leave these rivalries to develop, to create an artificial environment for a healthy competitive spirit between the players and to support them by purposefully including ranking, racing, and rally-type exercises into the training program. In my experience, team building happens differently for each sex: contrary to men's teams where the rivalry is often verbal and violent (“revolution with bloodshed”), in women's teams the inside fights are less visible, producing positive and quiet changes (“soft revolution”). Consequently, team structure becomes less solid, and disintegrates faster than in the men's teams.*

Behaviour on and off court - The general behaviour of society is also evident in sport. Women get offended quicker and hold a grudge longer. They are more sensitive to criticism and generally more respectful of authority. Men instead are explosive, but forgive faster and make peace easier. They are generally aggressive, always looking for competition and often challenge the coach.

- *If the training exercises are no longer challenging for a male player, he becomes bored and develops a destructive attitude. Conversely, women players are more tolerant – they don't mind as much the monotonous exercises and they cope better with frustration. In my experience, when coaching a men's team, handball knowledge and the playing history of the coach are more important for the male players. While in women's teams, human qualities, such as honesty, fairness and equal treatment are more important criteria than professional knowledge.*

Emotional life - The stability of the emotional life – thus the mood - is greatly influenced by the hormonal system. Due to the cyclic change of the hormonal level (oestrogen), after puberty in women, mood swings and changes in attitude are more extreme. In addition, the woman's brain produces half of the amount of serotonin (neurotransmitter connected with depression), therefore women become depressed twice as many as men.

- *Contrary to the relatively balanced and predictable mood of male handball players, in women's teams the coach needs to take into account the cyclical emotional mood swing of the players. Often their monthly cycle can determine their sporting performance. During this time, it is very important for the coach to be understanding, patient and sympathetic towards the player and in turn, she will usually show gratitude with a good performance.*

Pain threshold - Genetically woman's resistance to sickness is a little better and they live longer. Since women have more pain sensors than men, they feel the pain more acutely, their pain threshold is lower, they don't tolerate chronic pain easily and ask for medical assistance more often than men do.

- *In my experience, the coach has to show more empathy than for men when a woman player is injured. It needs to be accepted that female players initially react by panicking; they often start to cry, need more time to regroup and should not be rushed into returning to play. The inborn pride of the male player however, does not allow him to show weakness when injured, therefore in this case the coach should be cautious that the player may suppress a real injury and/or go back to play prematurely.*

When coaching male and female teams the abovementioned areas are only a starting point to help in better understanding players. However, it needs to be noted that these are generalisations and based on stereotypes. There are also "boyish" girls and "girlish" boys who make the distinctions between the two sexes less clear and more challenging in dealing with team preparation. Naturally, all players are individuals with different psychological, social and emotional backgrounds and needs - hence they have to be treated accordingly.

Yes, there is parity between the sexes. So when coaching them, should they be treated the same? Definitely not.....

marczinkaz@handballnet.hu

MINI HANDBALL – HANDBALL AT SCHOOL PROJECT IN SERBIA

Milan PETRONJEVIC

Serbian Handball Federation, Belgrade, Serbia

Summary

Serbian Handball Federation initiated **Mini Handball – Handball at School** project with the primary goal to launch the Handball Teams at wide spectrum of Elementary Schools throughout Serbia. This was selected as one of the main priorities of the Serbian Handball Federation for 2010 and for the upcoming years preparing for the EURO 2012. The additional aim of this project is to promote and popularize Handball among the elementary school children all over Serbia. There is a great opportunity to involve many school children in handball and to increase its popularity in Serbia. The projected time-line to complete implementation of the Mini Handball – Handball at School project in elementary schools is by year 2013 (i.e., the next 3 years) whereby notable results are expected to be seen in the year 2012, when the 10th European Championship is scheduled to be held in Serbia.

Specifically, the project is expected to include children from 1st to 4th school grade, in the 6-10 age groups, for both, boys and girls. Preliminary data for the school year 2010-11, indicate that 113 Elementary Public Schools were involved in the project, with total of 13.560 pupils. The school children (N=111) were evaluated based on their motivation to join the handball school teams. Having a good friend among the teammates was also a strong motivating factor to join their school team. Based on the number of children enrolled, it was concluded that mini handball was a dynamic and interesting sport game that may become the most adopted sport game for children of this school age. In the months after this program has been initiated, a large number of schools has adopted Handball as a part of curriculum and during the year 2011 SHF has registered more than 5.000 new players.

Our conclusion is that this program is an excellent way to promote sport in general and especially handball among youngsters. Serbian Handball Federation (SHF) has great expectations from this project based on the encouraging preliminary results.

Keywords: handball, children, age group 6-10, elementary school

Introduction

In the coming years of preparation for EURO 2012, Serbian Handball Federation (SHF) has initiated the **Mini Handball – Handball at School** Project and it has been determined as one of the main priorities. The aim of this project is to implement the Mini Handball long-term project, and to promote and popularize Mini Handball among school children all over Serbia. The other project tasks are: (i) Promoting youth sport; (ii) Popularizing the Mini Handball philosophy; (iii) Increasing the sport education among youngsters; (iv) Introducing fair play commitment; (v) Introducing the local handball clubs and motivating children to join their youth selections; (vi) Establishing the Mini Handball School League and Tournaments; (vii) Promoting the EURO 2012 event; (viii) Educating the pupils how to support the National Team and other handball teams. On the other hand, there is a growing body of literature supporting the health benefits of physical activity in young people (1-3). Low levels of physical activity are partially responsible for obesity and other health problems among youngsters. In Serbia, huge percent of physical activity occurs outside of physical education classes. Participation in youth sports programs offers children to obtain the recommended level of physical activity and to reduce health risks.

The purpose of this project is not only to promote handball but also to reduce the above mentioned problems related to health, ensure better position of handball in the curriculum of

physical education, and to evaluate children's motivation factors to join the Project and their handball school teams.

Methods

Subjects were 1st to 4th school grade children attending three public primary schools in Belgrade, Serbia. Two participation criteria were established for the school selection. Firstly, the local community in which the schools were located over the past several years offered a lot of sport programs for school children free of charge. It provided programs where children had fun and got acquainted with different physical activities (swimming, athletics, basketball, volleyball). All program activities were conducted by physical education teachers, sport specific coaches and volunteers from the local community. Secondly, since the Serbian Handball Federation is found in Belgrade, it was easy to organize and establish the collaboration with schools and local community for the Project implementation.

A total of 613 children were enrolled in these three schools. All parents were mailed a form and instructed to return the form to the school if they did not wish their child to participate in the Project. Children were free to refuse to participate at any time. The refusal rate was about 5%. We sampled a total of 111 school children aged from 9 to 10.

We collected data during the 1st class meeting. We informed the pupils that the participation was voluntary and responses confidential. The great majority of school children chose to participate. We instructed them to respond honestly, and the author was available to answer all the questions. Most participants completed the questionnaires in less than 10 minutes. All data analyses were done by using PC Statistical package.

A questionnaire was designed to measure how children are informed about handball, to measure their recent sport program participation, and their motivation factors to join the Project and handball school teams. Children were asked about their previous handball experience, "Have you ever played handball in a school or in a club?", "Have you ever watched a handball match?". Physical/sport activity was assessed by using questions: "Are you currently practicing any sport?". The evaluation of motivation factors has been done and it was retested after the first handball lessons.

Development (Results, Discussion)

Handball as part of the Primary School Curriculum

In public primary schools in Serbia Handball is part of the curriculum of the Physical Education subject. Physical education teachers should introduce handball to the pupils of the 5th grade. Pupils should have the opportunity to play handball and learn the basic handball skills, and finally their improvement and knowledge should be evaluated.

Pupils may also choose one of the sports from the list they would like to practice during the scholar year. Handball is part of the official school list, and pupils should have the opportunity to play handball in their schools once a week. This subject is called: **Optional Sport Discipline**.

Unfortunately, we must admit that handball in Serbian primary schools is not present as it should be. There are very few schools having Handball in their curricula, and handball is usually taught by the PE teachers who were once engaged in handball (former players, coaches, etc.). There are various reasons for this situation, and one of the most common arguments is that the size of school gyms & sport halls is too small for a handball court; handball rules are too complicated; handball tactics is not so clear; handball is too aggressive for pupils, etc. It is obvious that PE teachers are not well informed about Mini Handball philosophy and the possibility of its implementation in the PE classes.

Very well aware of the abovementioned facts the Serbian Handball Federation would like to change the status of handball in schools by implementation of the Mini Handball – Handball at School Project. Therefore, our aim was to introduce handball to every single school pupil all over Serbia.

Project description

For the implementation of this Project, the role of Regional Mini Handball Instructors is essential. Serbian Handball Federation has organized several seminars for them and we have registered over 50 instructors all over Serbia. Their task is to present SHF and promote the Mini Handball Project in the regions where they have been appointed. Their first task was to introduce the project to the school principals and to motivate schools to join the Project. After joining the Project, promotion of the Mini Handball in schools will be organized. Promotional activities were performed by the Mini Handball Instructor and the local Handball Club representatives (handball players and coaches). The PE teachers, in collaboration with the SHF Project representatives, were supported to organize an Inter-School Mini Handball Tournament, and other amusing handball activities. They were instructed to form a Mini Handball School Team. At least one boys' and girls' team (mixed team is acceptable too). School teams should have a training session at least once a week. After school teams were established in other primary schools from the same region as well (town or municipality), the SHF started to organize Mini Handball Tournaments and Mini Handball Regional School Leagues. Schools established their fan clubs and supporters. One of the most important Project tasks was to educate the youngsters how to support their own teams and to respect the opponents. Our aim was to form an extremely wide support for the Handball National Team for the coming EURO 2012 in Serbia.

SHF was strongly motivating schools to participate in the Project, to choose Mini Handball as the most convenient sport for boys and girls of the 4th and 5th grade. These schools, where Mini Handball is the part of the subject – **Optional Sport Discipline**, had a special treatment and support from the SHF.

SHF and the Faculty of Sport and Physical Education in Belgrade organized three Mini Handball seminars for PE teachers and other school teachers. So far, 200 teachers participated in these seminars, and we will continue this process of their specialization.

Project Results

In a word, results of the implementation of “Mini handball – Handball at School” Project were better than expected.

We have involved **139 public elementary schools** in our Project. Mini handball has been presented to **13.560 pupils** all over Serbia. In the period September 2010 – June 2011, Serbian Handball Federation organized **50 Mini handball activities and tournaments** with **6.709 young players** taking part. There were **4 Regional leagues** with **42 teams** and **559 players**. Admission for the **Regional Mini Handball Instructors** was repeated at the beginning of the last Scholar Season and their total number has risen to **50**. **Mini Handball Seminar for school teachers and PE teachers** has become a part of teacher's permanent educational process within the Serbian Ministry of Education. In the last scholar season it was organized all over Serbia and 211 teachers were attending it. This Seminar was approved for next scholar season by the Ministry of Education, and it will be a part of the Educational Catalogue for 2011/12.

Serbian Handball Federation is very satisfied with the Project results after Phase 1. All Project tasks were accomplished. Our assessment is that there are more than **5.000 new handball players in Serbia** due to the implementation of the Mini Handball – Handball at School Project. Pupils in Serbia are more informed about Handball and Mini Handball. Physical education teachers are more educated and motivated to play Handball with their pupils, and in a great many schools Handball is a very important part of their curricula. In 42 schools Handball is present as an Optional Sport Discipline, and we expect that this number will increase.

We would like to emphasize very good collaboration with EHF and several state institutions on this very important Project. Serbian Handball Federation has signed the EHF SMART Program as a long term measure of support for developing handball in Serbia. Project was also supported

by the Ministry of Sport and Youth, Ministry of Education, Faculty of Sport and Physical Education, Serbian Olympic Committee, local handball clubs. Serbian local authorities (Municipalities and their Sport Departments) were also of great support to this Project. Due to their positive influence and support, school children can play handball during the entire school year. All training sessions are organized by coaches from the local handball clubs. Tournaments and regional leagues are supported too.

Research results

Approximately 62% pupils stated that their sport activities occurred outside of physical education classes. The percent was similar when genders and grade levels were in question. Across schools, boys reported fewer taking part on PE classes during the week compared to girls. Just 15% reported that they had ever played handball, and 22% had ever watched a handball game. After these statements it was clear that only a small number of pupils would join their school team before a handball presentation. After the first class of handball presentation pupils were retested (interviewed) about their impressions of handball game. Approximately 92% stated that they enjoyed playing handball and that they find mini handball a very dynamic and interesting sport game, while 61% stated that they would like to play handball constantly. Boys were more motivated to participate in the handball program bearing in mind the competitive aspects, while the girls were more likely to report social reasons for participating in the handball program. Both genders primarily wanted to have fun playing handball and emphasized a good friend among teammates as a strong motivating factor to join their school handball team.

Although most previous studies have used a wide age range (7-18 years) in their study samples, “to have fun” remained the highest ranked reason for sport program participation (4, 5, 6). The number of pupils joining school handball team was much lower than it was stated in the questionnaire (61%). The reason for this may be the parents who still think of handball as a tough, brutal sport not appropriate for their child. On the other hand, recent club and national team results were not encouraging when the entire population was in question. In the recent years, basketball, volleyball and tennis, due to the good sport international results, are much more popular among youngsters in Serbia. Further research should attempt to understand these different sources of enjoyment and motivation, and their association with school handball program initiation, participation and implementation.

Conclusion

The Serbian Handball Federation is very satisfied with the first project results. A huge number of school children got acquainted with handball and participated in the Project all over Serbia. Handball is more present in PE classes and PE teachers are more educated and motivated to make their pupils play handball. School children find mini handball a very dynamic and interesting sport game. A good friend among teammates is also a strong motivating factor to join a school team. Based on these findings, it can be concluded that mini handball may be the most adopted sport game for children at this school stage.

Our opinion is that this project is a good way to promote handball among youngsters. Serbian Handball Federation (SHF) has great expectations from this Project and the first results are already encouraging. A huge number of schools has accepted handball as a part of curriculum and during the year 2011 SHF has registered more than 5.000 new players.

milan.petronijevic@gmail.com

THE POSITION OF MIRROR NEURONS IN LINKING APPLIED PSYCHOLOGY AND APPLIED PEDAGOGY

Wolfgang Pollany, PhD

BSPA Vienna / Austria

Summary:

An overview is given upon the status of research concerning the mirror neuron system in the human brain. From the very start of finding motor imitation activities in the brain of macaques (merely by chance) to the state of art experiments that seem to prove that the mns in the human brain is very well capable of not only imitating moves but as well to identify intentions and emotions the impact on education and learning is discussed.

Keywords: *Learning, Imitation, Motor Vocabulary, Empathy*

When we carefully observe the motion of somebody else, carrying out a specific task in sports, arts or in everyday life, our organism will absolutely imitate the full scale neural control mechanism. That means that by just observing a move we will imitate the activity down to micro-moves in our muscles in the end. This “Carpenter-effect” was detected and published before the end of the 19th century but it took more than 100 years until the source of this effect was found. A team of the University of Parma, led by G. RIZZOLATTI was doing research on the neural control of simple reaching moves of macaque monkeys when they found out that the same neurons in the F5 region of the monkey did not only fire when the monkey reached out for food but as well when the monkey observed somebody else reaching for food.

A series of very cautious and sophisticated tests followed before the group was absolutely positive that they somehow had detected the origin of imitation. Maria UMILTA stated that the monkeys were not only able to copy moves that they saw in total but they could also copy and finish moves when they had only seen the starting sequence. The key point was that they had to have information about the set up.

Funny enough the ability of imitation was limited by the specific knowledge of the operation: monkeys could not imitate pick up moves by using some tools which corresponds with the findings of Gordon GALLUP who proved that monkeys failed in identifying themselves in a mirror if they had no pre-experience with the function of a mirror.

With that RIZZOLATTI, GALLESE and IACOBONI turned to the research of the mirror neuron system in human beings. Supported by image giving procedures like the fMRT and the PET and by using TMS they found out that human were able not only to identify and copy the move but also the intention behind the move as long as this move belonged to the motor vocabulary of the respective person. This famous “tea-cup-experiment” was published in 2005 stating that chains of mirror neurons do in fact rebuild the intentions of the move observed. This was achieved by presenting different video clips showing an action, a specific context and the intention of a move. RIZZOLATTI stated by this that “*The bigger part of the neurons does not code single moves but motor acts.*” (Rizzolatti/Sinigaglia 2008, 37).

Backed up by the researches of RAMACHANDRAN, KEYSERS et al. and FOGASSI the concept of the human mirror neuron system was extended largely. Not only moves and intentions but feelings, emotions and empathy as well are transferred by the mirror neuron system. The following statements: “*Mirror neurons lead us to identify the intentions of others.*” (Iacobony

2011, 43) – “Mirror neurons of human are capable of cope not only the target of the motor act but as well the timing of the single moves of which it is composed.” (Rizzolatti/Sinigaglia 2008, 125) as well as the identification of specific sounds following KEYSERS - “It seems that our only chance to identify this noise is to simulate the action producing this sound or to imitate it internally.” (Iacoboni 2011, 46) summed up do lead us to a general concept of an implicit kind of understanding thus rejecting the traditional old concept of understanding by reflecting.

The scheme

Reception \implies Cognition \implies Movement

has to be substituted by the system of **direct matching**.

“Our brain is capable of giving sense to acts of others and by this to understand them directly without cognitions, just based upon personal motor abilities.” (Rizzolatti/Sinigaglia 2008, 14).

What does this mean to the concepts of education in general and in the education of coaches and referees in particular?

For education in general it just underlines the fact that “education is the living demonstration of a certain set of values” (Pollany 2006, 2) in principle. Therefore the demand on the personality and the competence of the leader is pretty high. A key factor in this relationship is the issue of authority. Authority is a bilateral system based upon acceptance without pressure. Bilateral means that authority must be given by the addressed person thus stating the fact that education needs cooperation of the addressed as a basic requirement. Without the readiness for cooperation by the pupil, student or athlete the whole process cannot be started due to a certain procedure in our limbic system.

There is a direct connection between the mirror neuron system and the limbic system via an area of the brain that is called **insula**. This connection has been proved by IACOBONI in his experiment with portraits of people showing expressions of different emotions thus leading to the “Facial-Feedback-Hypothesis”. But this connection at the same time does work the other way around as well. Our limbic system, namely the Hippocampus checks the incoming information whether it is of interest or not. And only in case of rating the information worth while the mirror neuron system will be activated. That means that in the end all information has to be presented in a way evoking interest – a challenge for all lecturers, teachers and coaches. If this is not the case, the attention of the audience will turn to something else rated more interesting by their system. Moving on to language and verbal teaching we start on the grounds of LIBERMAN’s motor theory of language perception. This theoretical concept has been backed up by researchers FADIGA, WILSON and MEISTER and summed up in this statement: “In order to understand the words of somebody else it is in fact necessary to mirror them.” (Iacoboni 2011, 115)

But this means that the presenter has to use a language which the students are in command of. Therefore it is very difficult to transfer the knowledge that someone has gained from university lectures to kids in primary schools. The same applies in sports with the transfer of top level concepts to athletes of less experience and class.

With this we have already switched to particular challenges in the education of coaches and referees/delegates.

Talking about coaches they have to adjust their presentations and demonstrations to the level of their respective players. This gives a massive problem in case a top coach decides to work with a low level team. Even if he/she tries very hard every now and then overload of the players is more or less inevitable. A lot of patience and mutual understanding is necessary to avoid conflict. And just one player tackling the authority of the coach can cause the collapse of the whole system.

It is not clear yet to what extent verbal explanations can evoke motor knowledge due to the mass of mirror neurons in the BROCA-region. Rizzolatti's statement "*If understanding is possible on different grounds....., mirror neurons are able to cope the ... action without any optic stimulus.*" (Rizzolatti/Sinigaglia 2008, 112) connected with the theory of LIBERMAN mentioned above has borne the impression that excellent verbal description might be sufficient in many cases.

In terms of the education of referees/delegates I do have massive doubts. There will be a huge number of situations during a game that cannot be defined verbally to the extent. Also there are situations that one can call correctly only knowing the situation from the experience as a player or having a different context to find it in the personal motor vocabulary. Looking at the present situation with the education of the referees/delegates most of them are forced to start their career quite young. That means that they never had the chance to gain a motor vocabulary in handball that will match with the one of a top player or an experienced coach who had been a player of good class before. So they do lack of the chance to detect and understand intentions and actions of players in crucial situations because they do not have a copy of the situation in their vocabulary available. The ultimate effect is the statement that they do know all the rules by heart but they do not know the game and therefore their calls are disastrous. But using the mirror neuron system we do have a direct and easy way to give them the necessary information for their motor vocabulary.

A quick and straight way is to do a huge lot of short video clips showing crucial situations from different angles in real time. This should be repeated 3 times, followed by one slow motion and another presentation in real time. It is necessary to show the start of the action, the full sequence and the outcome including consequences. These clips might be summed up with headlines and collected in a few DVDs. This is the first part of the concept. The second part is to organize a seminar for the referees/delegates focusing on the watching and the uptake of the material – the learning technique for adjusting the information into the vocabulary by means of the mirror neuron system. This teaching concept shall be started from all sides: All our lecturers shall be familiar with the concept of learning by the mirror neuron system. It has to be part of the top referee seminars, the mini courses and the young referee program. At the same time it has to be presented to the chiefs of referees and implemented in the courses of national education of referees/delegates.

I want to point out that the instrument is not new but the application of the teaching tools will be much different from the past. We have to say farewell to the over aged idea of only calling what you see. The ultimate target is to call what you see, feel and know.

wolfgang.pollany@aon.at

EFFECT OF THE DECISION MAKING PROCESS IN THE SPEED OF DEFENSIVE DISPLACEMENT IN HANDBALL

Jesús RIVILLA, Jorge LORENZO, Amelia FERRO and Javier SAMPEDRO

Faculty of Physical Activity and Sport Sciences. Polytechnic University of Madrid (Spain)

The present study aim to analyze the influence of the decision making process in the speed of defensive specific displacement in professional team handball players. The analysis of differences stated significantly major values in the test without decision making process that with opposition. The results allowed to confirm that the decision making process had a negative effect on the speed of defensive displacement.

Keywords: *team handball, velocity, specific fitness, test.*

INTRODUCTION

Traditionally, it has been estimated the speed of movement is dependent on three factors: the technique, the temporal coordination of the actions of the different body segments and the strength and power of the lower muscles. However, for some time, some authors suggest that cognitive factors, perception and decision making can influence the specific actions of the game with high conditional component, such as high intensity movements.

However, few studies have assessed the movement speed with any kind of opposition or decision making, however they seem to portend that these factors may influence the specific physical condition. More specifically, Parraga et al. (2001) examined the speed of release depending on visual stimuli from the goalkeeper and found differences depending on the situation of the size of it. In the same vein, Lopez (2005) found differences in the prior steps of the jump throw with and without opposition, and obtained values lower in throwing velocity without opposition, although these differences were very slight. Confirming this, Pardo et al. (2007) found that the speed of ball in throwing with opposition (defenders and goalkeeper) can vary depending on the type of throw, the prior steps of the jump throw, the position of goalkeeper, the performance of the defenders and the goalkeeper, noting also a decrease throwing velocity without opposition.

This influence of the opposition and decision making in the specific physical condition is corroborated in other team sports. Thus, water polo, where the release is of great relevance, Van der Wende (2005) compared the throwing velocity with and without opposition, noting that throwing velocity decreased in the presence of the goalkeeper and defenders. In a similar study, Vila, Ferragut, Argudo, Abraldes, Rodriguez, and Alacid (2009) obtained similar results regarding the decrease of speed in the presence of the goalkeeper.

According to these investigations, Garcia Navarro, Ruiz and Martin (1998) confirmed in a practice with students college football, the correlation between displacement speed test was decreasing as they approach specific situations, confirming the influence of coordinative factors, technical, and cognitive, tactical, the movement speed with the ball. On the basis of previous studies and considering a possible influence of the opposition in the speed of movement, we performed this study to analyze the differences between the speed of movement with and without opposition in professional handball player.

METHOD

Sample

The sample was composed of 45 professional handball players from three elite teams, militants in the highest category of Spanish handball (Asobal League)

The characteristics are presented in Table 1:

Table 1: General characteristics of the sample ($x \pm SD$).

CATEGORY	N=	AGE (years)	HEIGHT (cm)	WEIGHT (kg)	OBSERVATIONS
Elite (E)	45	27,3 \pm 3,11	195 \pm 5,28	91,12 \pm 9,12	Asobal League

Procedure

All the participants were tested (test 10x5m) in two situations: a) test without decision-making (Fig. 1) and b) test with decision making (Fig. 2).

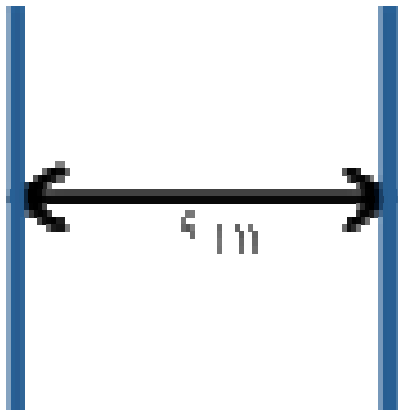

Fig 1. T1: Test without making decision

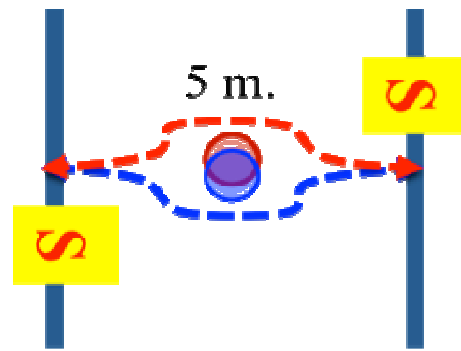

Fig 2. T2: Test with making decision

The participants were carefully informed about the procedure to be performed and gave their voluntary consent to participate in the study. It was performed a specific warm consisting of standardized specific movements varied, with special emphasis on acceleration and braking. After warming up, participants were informed in detail of each test protocol through various executions prior to testing. The instructions common to both tests were to move to the maximum possible speed from one side to another, the player had to step on each line before running the other side, should be 10 times the distance of 5 m. Each participant, in each of the tests, carried out the test to be registered three values of each test, selecting the best for later analysis.

Material

The tests were performed on a handball court. The record time was made with an accuracy of 0.001 using a timing system (Sportmetrics, Valencia, Spain) composed of a sensor composed of photoelectric cells. The sensor was composed of eight vertical photocells and uniformly distributed, with a separation between them of 15 cm (range 1.40 to 2.50 m above ground). The timing of the time automatically starts when the player went through the photocells and the player was arrested after crossing the line 5 times. In T2, with decision-making, an extra sensor was placed on the two lines that activated one of the lights randomly located between the two lines (red or blue). The player must pass through the area contrary to the light was on. To control the movements of the players in the test is placed a video camera.

Statistical analysis

Means and standard deviations of the variables were calculated. Also, we applied the Pearson correlation coefficient to analyze the relationship between these variables and the t test to analyze differences between means of the players belonging to the study sample. Statistical calculations were performed with SPSS 10.0.

RESULTS AND DISCUSSION

According to the review made, it was found that there was little research to analyze the relationship and differences between fitness test with and without making-decision.

The movement speed without making decision was 5% better than with decision-making ($p < 0.01$, $t = 7.601$, $df = 44$). The relationship between the two tests was positive and moderate ($r = 0.812$, $p < 0.01$). More specifically, the value of T1 was better than the T2 in the three groups analyzed, the differences being around 5% and statistically significant ($p < 0.01$). This seems to be consistent with the data obtained by Pardo et al. (2007) who obtained much higher values in throwing velocity without opposition than with opposition. In contradiction with these data is the research done by Lopez (2005) which, although found differences in the prior steps of the jump throw, obtained similar values in throwing velocity with and without opposition. This contradiction could be due to the throwing technique is very different to that carried out at the standing throw done in the present study.

However, the data obtained in this study correspond to the two other studies (Van der Wende, 2005, Vila et al., 2009). Both studies found differences in throwing velocity with and without opposition, lower values observed in the presence of the goalkeeper. However, these investigations were conducted in another sport, water polo.

On the other hand, the fact that the correlation values between the two speed tests are not high could be a significant finding that corroborates the differences between both tests. In this sense, it is noteworthy that, although both tests have a similar technique, the relationship is not high. This could be due to the marked differences in the degree of cognitive involvement and decision making of the two situations described in the study.

CONCLUSIONS

Decision-making influences the speed of displacement, decreasing it. The relationship between movement speed without and with decision-making is positive and significant. Therefore, we consider important to continue conducting studies on the influence of cognitive factors in specific physical capabilities, suggesting the possibility that these factors may also influence the specific physical condition of other team sports.

jesus.rivilla@upm.es

EFFECT OF NEW TECHNOLOGIES ON THE ABILITY TO ANALYZE SITUATIONS SPORTS IN UNIVERSITY STUDENTS

Jesús RIVILLA, Jorge LORENZO, Amelia FERRO y Javier SAMPEDRO

Faculty of Physical Activity and Sport Sciences-INEF/Polytechnic University of Madrid, SPAIN

SUMMARY

This study examined the effect of the use of ITCs in the ability of perception and analysis competitive situations by university students of basketball, handball and athletics. The results confirmed a significant improvement in the three groups. Therefore, the frequent and active use of new technologies has a positive impact on improving the ability to appreciate and analysis of sports.

Keywords: perception, ICT, athletics, handball, basketball

INTRODUCTION

At present, the use of Technologies of the Information and the Communication (ICTs) in order to optimize the learning in different areas begins to be very frequent. The benefits of the application of the ICT's in the education are multiple: facility of access, flexibility, the pedagogy centred on the pupil and the best opportunities of collaboration. For all this, his integration in the systems of education and formation, specially in the top education, constitutes one of the principal worries of the EU [1-2].

Up to the moment, the majority of the models, systems and plans of evaluation of the usefulness of the use of the ICTs in the classrooms centre only on the utilization of the technological elements and not on his pedagogic integration or in the value that these have inside the program of formation [3].

Though every time there is more frequent the utilization of this type of means in the education in the university, as way to increase the motivation of the student [4], we have detected that exist very few investigations that demonstrate his efficiency and none in reference to the university centers of our speciality: Faculties of the Physical Activity and of the Sport. In our opinion, the use of audio-visual means might favor the learning of different contents of education of the Sports.

In the present document, one gives continuation to a study realized across a project of Educational Innovation (" Design and applications of new methodologies: production of materials of support to the teaching of the team sports "), financed with a help granted by the UPM during the courses 2006/07, 2007/08, 2008/09 and 2009/10, and it uses on behalf of those of the audio-visual materials elaborated in the above mentioned projects.

Educational Innovation Group: Sports Collectives FCCAFyD-INEF has conducted research, developed with the help of the Polytechnic University of Madrid, whose main purpose is to analyze the utility of new technologies to improve teaching - learning in the subjects concerning the application of sports in the Faculty of Physical Activity and Sport (INEF-Madrid). The aim, therefore, to evaluate the effect of the application of the Technologies of Information and Communication (ICTs) in the education of the sports, particularly in the Handball, Basketball and Athletics.

METHODS

Participants

The sample was composed by 56 pupils, divided in three groups: (i) Group "Athletics" (n=17), the (ii)nd Group "Handball" (n=21) and the (iii)rd Group "Basketball" (n=18). These groups concerned to the subject " Sport of High Performance ", of 8 credits, which is dealt in the second cycle of the Master in Sciences of the Physical Activity and of the Sport in the Faculty of Sciences of the Physical Activity and of the Sport (INEF) of the Technical University of Madrid.

Material

For the initial evaluation (Initial Test) and end (Final Test) of three groups, the only questionnaire was in use. The pupils had to observe several sequences of video and images and categorize them correctly from the technical - tactical and regulation point of view, determining the consequence of the observed action. For the development of the classes there was in use frequently a projector connected to a portable computer of great memory for the storage of the contents multimedia. Equally, the pupils had a portable computer for the accomplishment of the works related to the new technologies. One possessed five portable ones for his lending. For the categorization, selection and analysis of the sequences of video there was in use a program of edition of specific video (Skaut Systems).

Procedure

On having begun the semester of class and on having finished the same one, there was evaluated the level of perceptive capacity and of analysis of each one of three groups. Along the semester, three groups followed similar methodologies of education with regard to the utilization of the TIC's, based on a high use of the same ones and in his practical application.

The theoretical classes included the use of audio-visual means to the beginning and at the end of the same ones. The developed contents were the own ones of every subject, being in use the TIC's and the contents multimedia in all the theoretical presentations. Above mentioned material multimedia was also of free access in the virtual institutional platform of the UPM. When existed great quantity of material available multimedia for the pupils, a major effort was necessary for the diffusion and exchange of information. The practical classes realized with a brief theoretical introduction that it was including photos and you sequence multimedia explanatory. At the end of the practical meetings one was thinking about the same ones, with a new support of material multimedia.

The structure of the meetings was very similar in three workgroups.

Additional, the pupils realized works and complementary tasks related to the new technologies.

These are some examples:

- Work of analysis and selection of images and sequences of video extracted from royal competitions, cataloguing them adequately from the regulation and technical point of view - tactically.
- Accomplishment of video - assembly of actions realized by the own pupils.

Statistical analysis

The obtained information was analyzed by means of the statistical package SPSS 15.0 for Windows. The calculation of the averages and diversions standard was realized by means of statistical methods standard. To analyze the differences between groups from the initial test and the final test in each of the groups applied to itself the T test for related samples.

RESULTS AND DISCUSSION

The results obtained in both test are presented in the table 1. First, different initial punctuations were observed in three groups. Nevertheless the differences in the initial evaluation between groups were not significant. Equally, a significant improvement was observed in the results of three analyzed groups, being minor the improvement in the group of the individual sport "athletics".

	PERCEPTIVE CAPACITY AND ANALYSIS (PA)		
	Initial (Media±DT)	Test (Media±DT)	Final (Media±DT)
ATHLETICS GROUP	4.74 ± 1.71	6.17 ± 1.95	1.44 ± 0.84**
BASKETBALL GROUP	4.77 ± 1.04	7.05 ± 1.12	2.27 ± 1,36**
HANDBALL GROUP	3.05 ± 1.49	7.47 ± 1.58	4.43 ± 1.88**

Table 1.-Results of the initial and final evaluaciones and his differences (DT Happens ±)

** It shows significant differences $p < 0.01$

Initially, the application of Anova's test, it determined that in the initial test significant differences between the groups did not exist. Which might be significant of a similar level of item in three analyzed groups. And, of equal way, the differences in the final test, were not also significant, which might mean that the improvement is not so much due to the different teachers but to the used methodology.

This affirmation is checked on having analyzed the differences between the initial and final punctuation in every group. The application of the test T de Student for related samples confirmed significant differences in all the groups ($p < 0,01$) though of different magnitude. The opposing differences were top in the group handball that in basketball, being minor in athletics.

These results allow to affirm that the use of the new technologies this one directly related to the efficiency in the learning process, concretely of the capacity of analysis and perception of the game in Athletics, Basketball and Handball in the Faculty of Sciences of the Physical Activity and of the Sport (INEF) of the Technical University of Madrid.

In future studies, we try to research in different sports and with different contents (technical, tactical and strategic), to verify if these results are applicable to other sports disciplines and in different levels of learning (monitors, trainers, pupils of secondary and primary, sportsman of the studied speciality of different levels of practice and age, etc).

These results are opposed to a previous study not published, realized by our group, in which one was concluding that an active and very frequent use of the ICT's was not improving the results with regard to the pupils who were using it in a passive way (by means of the observation of the contents showed by the teacher), and that the high use of the technology in the classes was generating a negative vision of the subject, owed probably to the substantial increase in the hours dedicated on the part of the pupil to the subject, on the basis of the major request of works to fulfill the minimal requirements of the subject.

CONCLUSIONS

In the light of the results obtained in three evaluated groups, it is possible to conclude that the use of the new technologies reverberates of direct form in the improvement of the perceptive capacity and of analysis of the student body to university level in Athletics, Basketball and Handball. Equally, the frequent and active utilization of the ICT's seems to relate to the optimization of the learning of the contents of the sports, logical question to tenor of which

without utilization of audio-visual means (traditional methodologies) or similar means difficultly it will be possible improve significantly in capacities of perception and analysis of the same one. Consistently, the values obtained in the improvement of the learning allow to affirm that the use of the new technologies can be directly related to the efficiency in the learning process of the sports in pupils of the Faculty of Sciences of the Physical Activity and of the Sport (INEF) of the Technical University of Madrid.

An active use of the TIC's carries to optimize the results. This can be a consequence of to the substantial increase in the hours dedicated on the part of the pupil to the subject, due to the major request of works to fulfill the minimal requirements of the same one.

PRACTICAL REFLECTIONS

The present study is born of the belief of the importance of using the new technologies in the optimization of the process of education - learning of the sports in the different levels. In the light of the contributed information, the above mentioned affirmation seems to be ratified, nevertheless, it would be opportune to penetrate into this question since there are very small the studies that confirm these question. It would be necessary to determine which is the most suitable degree of utilization of new technologies and which are the most effective traditional means and that should not be rejected in the education of the sports.

On the other hand, one of the most relevant capacities in the sports area is to perceive correctly the situations of competition - training and, later, to take decisions adapted from the above mentioned perception. Bearing in mind that one the fundamental aims in subjects of the different sports is to acquire these capacities related to the perception and capture of decision, it seems to be opportune to look for the means of learning most adapted for the above mentioned acquisition. Of between all, it seems to be coherent to think about a high usefulness of the TIC's for the achievement of perceptive significant learnings. In this line it seems to be important to question in what measure the perceptive capacities are relevant and of analysis of royal actions of the game in the education of the sports to professional futures of the same one.

It thinks that the frequent use of new technologies increases the motivation and satisfaction of the pupil with the subject really is it like that?, the utilization of the TIC's do they increase in a significant way the motivation of the student body? And, in case this way it is, might improvements in the education owe to this bonus of motivation?

We wonder also if there will depend the usefulness of the TIC's of the matter or content that is wanted to give?, or what is the same thing, are TIC's equally useful in the different sports and matters related to the sports area?

The exposed study centres his attention on the education of the sports. Habitually this education has centred on the acquisition of knowledge as well as of skills of the sport, having in it counts the possible professional labor that the pupil will have to recover as trainer and / or teacher, should this perspective be extended towards the perceptive capacities, of analysis and capture of decision in the game or session of training? Are not they these equal or more relevant than capacities previously treated?

Finally, which are the most important capacities that might be promoted thanks to TIC's's habitual use in the education? It is necessary to suppose that the capacities related to the perception and audio-visual analysis need of the TIC's for his utilization, nevertheless, would it be equally productive in other capacities?

jesus.rivilla@upm.es

MULTIDIMENSIONAL EVALUATION OF YOUNG HANDBALL PLAYERS: DISCRIMINANT ANALYSIS APPLIED TO TALENT SELECTION

Helena VILA¹, Ferran RODRIGUEZ², Ia VAZQUEZ³, Juan FERNANDEZ⁴

1: UCAM (Murcia); 2: UB (Barcelona); 3: UAX (Madrid); 4: UDC (A Coruña), Spain

The aim of this investigation was to analyse different anthropometrical, physical fitness and training characteristics of young handball players of different categories from a multidimensional perspective, in order to obtain statistically developed reference norms for various testing procedures, and to build multivariate models that could predict performance level at different age periods. 105 handball players with ages between 13-18 years old participated in the study, which was made choosing the best players of the Galician Handball Federation (Spain). They were grouped into three official categories: 13-14 (U 14's), 15-16 (U 16's), and 17-18 (U 18's). The multidimensional evaluation procedures included: 1) a specific questionnaire to analyse their sport participation background and training status; 2) a complete anthropometrical evaluation, including body composition analysis, somatotyping, and sexual maturation rating; 3) the Eurofit test battery (Council of Europe 1988) to measure general physical fitness; and 4) a vertical jump test battery (SJ, CMJ, and Abalakov). Different multivariate models were developed using discriminant analysis techniques (stepwise selection) to discriminate between players who were selected or not to play. The predictive capacity of the multivariate models developed by discriminant analysis, concluded that more of the 95% of players were accepted when all variables were included. The variables entering the multivariate models with highest predictive value were predominantly those derived from physical fitness and anthropometrical tests. Training levels appeared only at the oldest category group. From these results, we conclude that the best age for talent detection based on this type of multidisciplinary evaluation (sports background and training status questionnaire, anthropometry, and physical fitness comprehensive testing) seems to be 15-16 years of age (U 16's category).

Introduction

It is generally accepted that objective talent selection in sports should take into consideration, the analysis of several individual factors relevant to performance, including the anthropometrical, physical fitness and training characteristics of young players. A multidimensional approach based on multivariate analysis has been successfully used to predict performance levels at different age periods in tennis, which is an individual sport (Solanelas & Rodríguez 1996; Saavedra, Escalante, & Rodriguez, 2010), and collective sports (Burr et al., 2008; Coelho et al., 2010; Elferink-Gemser, Visscher, Lemmink, & Mulder, 2004, 2007; Falk, Lidor, Lander, & Lang, 2004; Gabbett, Georgieff, & Domrow, 2007; Reilly, Williams, Nevill, & Franks, 2000; Lidor et al., 2005; Mohamed et al., 2009; Vila, 2002).

The aim of this investigation was to analyse different anthropometrical, physical fitness and training characteristics of young handball players of different age categories from a multidimensional perspective, in order to obtain statistically developed reference norms for various testing procedures, and to build multivariate models that could successfully predict performance levels at different age periods.

Methods

Subjects

A total of 105 masculine handball players with ages between 13-18 years old participated in the study, which was made choosing the best players of the Galician Handball Federation (Spain). They were grouped into three official categories: 13-14 (U 14's), 15-16 (U 16's), and 17-18 (U 18's).

The study was approved by the Bioethics Committee of the University of A Coruña (Spain). The parents or legal tutors, of these players have signed an informed written consent previously to their participation.

Assessment Procedures

All subjects undertook a comprehensive battery of tests, which included assessment in the following domains: (a) sports background and training status, (b) anthropometry, (c) general fitness tests, (d) specific fitness tests, and (e) multidimensional evaluation. In concordance with the aims of the study (i.e., to develop multivariate models explaining handball players performance from a multidimensional perspective), a considerable number of assessments were included as predictive variables to ensure comprehensive evaluation.

Sports Background and Training Status

This domain was assessed by an *ad hoc* questionnaire including 16 items: 5 related to social background, 5 on sports practice, and 6 items on handball training and competition. This questionnaire assessed the relationship between handball player's performance and variables such as previous sports, handball practice, and number of weekly training sessions.

Anthropometry

Anthropometric measurements were taken according to standardized procedures (Ross and Marfell-Jones, 1982) by an ISAK (International Society for the Advancement of Kinanthropometry) certified anthropometrist. Measures include body dimensions (height, sitting height, arm span, and weight), lengths and widths (hand and foot), skin folds (triceps, subscapular, biceps, supraspinale, abdominal, front thigh, and medial calf), breadths (biacromial, biiliac, bitrochanteric, knee, elbow, and wrist), girths (chest, arm flexed, gluteal, thigh, and leg).

Body composition was assessed using a two-compartment model (Malina y Bouchard, 1991). Sum of six skin folds was used as main adiposity index. Somatotype was determined using the anthropometric method (Carter y Heath, 1990), and the three components (endomorph, mesomorph, and ectomorph) were analyzed separately. Sexual maturation was assessed from the development of secondary sex characteristics according to Tanner (1962).

General Fitness Tests

General fitness was assessed using the Eurofit test battery (Council of Europe, 1998): shuttle run test assessed general aerobic endurance, flamingo balance assessed general

balance, plate tapping assessed segment velocity of the upper limbs, sit and reach assessed flexibility of the body and lower limbs, horizontal jump assessed explosive strength of the lower limbs, hand dynamometry assessed grip, abdominals in 30 s assessed body power, flexed arm hang assessed muscular resistance of the arms and shoulders, and shuttle run test 10 × 5 m assessed agility-velocity.

Specific fitness tests

Each subject performed three kinds of maximal jumps on a Jump Mat (Ergo Jump Bosco System ®, Byomedics, SCP, Barcelona, Spain). The squat jump (SJ), starting with knees bent at 90° and without previous counter movement. The counter movement jump (CMJ), starting from a standing position allowing for counter movement, with the intention of reaching knee bending angles of around 90° just before jump. The subjects kept their hands on their hips throughout the jumps, in order to avoid the possible contribution of the arms to the jump. The Avalakof jump is a variation of the vertical jump test, used for measuring leg power. In this test, arm swinging is allowed to assist, generating maximum height. Subjects completed three attempts of each type of jump and the best one (in terms of flight time) was used for the subsequent statistical analysis. For motivational purposes, players were immediately informed of their performance. Between jumps, subjects were allowed to recover for three minutes to avoid fatigue. Jump height was calculated with the flight time.

Multidimensional Evaluation

Combined analysis of variables from the different domains (sports background and training status, anthropometry, general fitness tests and specific fitness tests) was made by developing multivariate models (see Statistical analysis for details).

Statistical Analysis

Unless specified, data are expressed as means \pm SD (*SD*). The normality and equal variance of the distributions were tested using the Kolmogorov-Smirnov and the Levene tests, respectively.

In discriminant analysis (DA), subjects were classified by the sample-splitting method in four groups according to their performance level (selected and not selected) using a stepwise selection procedure. The criterion used to determine whether a variable entered the model (i.e., discriminant function) was Wilks's Lambda, which measures the deviations within each group with respect to the total deviations. The sample splitting method included initially the variable that most minimized the value of Wilks's Lambda, provided the value of F was greater than a certain critical value (i.e., $F = 3.84$ to enter). The next step was pair wise combination of the variables with one of them being the variable included in the first step. Successive steps were performed in the same way, always with the condition that the F-value corresponding to the Wilks's Lambda of the variable to select has to be greater than the before mentioned "entry" threshold. If this condition was not satisfied, the process was halted, and no further variables were selected in the process. Before including a new variable, an attempt was made to eliminate some of those already selected if the increase in the value of Wilks's Lambda was minimal, and the corresponding F-value was below a critical value (i.e., $F = 2.71$ to remove). Wilks's Lambda, canonical correlation index, and percentage of subjects correctly classified.

Table 1. Predictive capacity of multivariate models (discriminant analysis) developed from the multidisciplinary evaluation of young male handball players (n= 105).

Multidimensional evaluation	13-14 (INF)	15-16 (CAD)	17-18 (JUV)
All discriminant functions and variables included			
Canonical correlation index	0.97	0.92	0.94
Correctly classified (%)	92.7	97.3	96.7
First discriminant function included only			
Canonical correlation index	0.78	0.62	0.41
Correctly classified (%)	81.6	83.8	36.3
Variables entered	Arms span	Mesomorphism	Training sessions/wk
	Standing long jump	CMJ	Trochanterion height
	Plate tapping	Plate tapping	Sit & reach
	Hand dynamometry		Arms flexion
	Hand length		Biacromial breadth
	Thigh girth		CMJ
			Sum of 4 skinfolds
			Thigh girth

The predictive capacity of multivariate models developed by discriminant analysis reached more of 95% of players correctly classified when all measured variables were included (Table 1).

Variables entering the predictive model using the first discriminant function varied for each age category group, and correct classification percentage significantly decreased at the oldest age category (U 18's). The variables entering the multivariate models with highest predictive value were predominantly those derived from physical fitness and anthropometrical tests. Training level appeared only at the oldest category group.

Conclusions

Altogether, these results support the notion of the multidimensional nature of this sport. The best age for talent detection based on this type of multidisciplinary evaluation seems to be 15-16 years of age (U 16's category), when coordinative and cognitive factors probably begin to play an increasingly important role in handball performance.

These results could be particularly helpful in talent selection and development in younger players, since descriptive data may also be used as norm-reference values for testing.

hvila33@gmail.com

MULTIDIMENSIONAL EVALUATION OF HANDBALL PLAYERS: TALENT SELECTION BY DISCRIMINANT ANALYSIS

Helena VILA¹, Ferran RODRIGUEZ², Juan FERNANDEZ³, Carmen FERRAGUT⁴

¹UCAM (Murcia); ²Universidad de Barcelona (Barcelona); ³UDC (A Coruña); ⁴University of Alcalá de Henares (Madrid). Spain.

Summary

The aim of this study was to analyse different anthropometrical, physical fitness and training characteristics of young female handball players of different age categories from a multidimensional perspective. The predictive capacity of multivariate models developed by discriminant analysis reached around of 90% of players correctly classified when all variables were included.

Keywords: *Evaluation multidimensional, Discriminant analysis, Talent.*

Introduction

Sports performance is the result of a complex process involving many factors. Performance capacity has been studied using a multidimensional assessment approach in different sports (Burr et al., 2008; Coelho et al., 2010; Elferink-Gemser, Visscher, Lemmink, & Mulder, 2004, 2007; Falk, Lidor, Lander, & Lang, 2004; Gabbett, Georgieff, & Domrow, 2007; Reilly, Williams, Nevill, & Franks, 2000; Saavedra, Escalante, & Rodriguez, 2010). Nevertheless, in handball there are very few studies published (Fernández, Vila, & Rodríguez, 2004; Lidor et al., 2005; Mohamed et al., 2009). The performance is considered a discrete variable, usually categorized in two groups (i.e., selected/nonselected, elite/nonelite), discriminant analysis seems to be the preferred technique (Gabbett, Georgieff, & Domrow, 2007; Reilly et al, 2000; Fernández, Vila, & Rodríguez, 2004).

The aim of this investigation was to analyse different anthropometrical, physical fitness and training characteristics of young female handball players of different age categories from a multidimensional perspective.

Methods

Subjects

A total of 91 female handball players aged 13-18 years participated in the study, selected among the best players of the Galician Handball Federation (Spain). They were grouped into three official age categories: 13-14 (INF), 15-16 (CAD), and 17-18 (JUV). The study was approved by the Bioethics Committee of the University of A Coruña (Spain). The handball players' parents or legal tutors signed an informed written consent previously to their participation.

Assessment Procedures

All subjects undertook a comprehensive battery of tests, which included assessment in the following domains: (a) sports background and training status, (b) anthropometry, (c) general fitness tests, (d) specific fitness tests, and (e) multidimensional evaluation. In accordance with the aims of the study (i.e., to develop multivariate models explaining handball playing performance from a multidimensional perspective), a considerable number of assessments were included as predictive variables to ensure comprehensive evaluation.

Sports Background and Training Status

This domain was assessed by an *ad hoc* questionnaire including 16 items: 5 related to social background, 5 on sports practice, and 6 items on handball training and competition. This questionnaire assessed the relationship between handball player's performance and variables such as previous sports, handball practice, and number of weekly training sessions.

Anthropometry

Anthropometric measurements were taken according to standardized procedures (Ross and Marfell-Jones, 1982) by an ISAK (International Society for the Advancement of Kinanthropometry) certified anthropometrist. Measures included body dimensions (height, sitting height, arm span, and weight), lengths and widths (hand and foot), skinfolds (triceps, subscapular, biceps, supraspinale, abdominal, front thigh, and medial calf), breadths (biacromial, biiliac, bitrochanteric, knee, elbow, and wrist), girths (chest, arm flexed, gluteal, thigh, and leg).

Body composition was assessed using a two-compartment model (Malina y Bouchard, 1991). Sum of six skinfolds was used as main adiposity index.

Somatotype was determined using the anthropometric method (Carter y Heath, 1990), and the three components (endomorph, mesomorph, and ectomorph) were analyzed separately. The age of menarche was assessed by recall.

General Fitness Tests

General fitness was assessed using the Eurofit test battery (Council of Europe, 1998): shuttle run test assessed general aerobic endurance, flamingo balance assessed general balance, plate tapping assessed segment velocity of the upper limbs, sit and reach assessed flexibility of the trunk and lower limbs, horizontal jump assessed explosive strength of the lower limbs, hand dynamometry assessed grip, abdominals in 30 s assessed trunk power, flexed arm hang assessed muscular resistance of the arms and shoulders, and shuttle run test 10 × 5 m assessed agility-velocity.

Specific fitness tests

Each subject performed three kinds of maximal jumps on a Jump Mat (Ergo Jump Bosco System®, Byomedics, SCP, Barcelona, Spain). The squat jump (SJ), starting with knees bent at 90° and without previous counter movement. The counter movement jump (CMJ), starting from a standing position allowing for counter movement, with the intention of reaching knee bending angles of around 90° just before jump. The subjects kept their hands on their hips throughout the jumps, in order to avoid the possible contribution of the arms to the jump. The Avalakof jump is a variation of the vertical jump test, used for measuring leg power. In this test, arm swinging is allowed to assist in generating maximum height. Subjects completed three attempts of each type of jump and the best one (in terms of flight time) was used for the subsequent statistical analysis. For motivational purposes, players were immediately informed of their performance. Between jumps, subjects were allowed to recover for three minutes to avoid fatigue. Jump height was calculated with flight time.

Multidimensional Evaluation

Combined analysis of variables from the different domains (sports background and training status, anthropometry, general fitness tests and specific fitness tests) was made by developing multivariate models (see Statistical analysis for details).

Statistical Analysis

Unless specified, data are expressed as means \pm SD (SD). The normality and equal variance of the distributions were tested using the Kolmogorov-Smirnov and the Levene tests, respectively.

In discriminant analysis (DA), subjects were classified by the sample-splitting method in four groups according to their performance level (selected and not selected) using a stepwise selection procedure. The criterion used to determine whether a variable entered the model (i.e., discriminant function) was Wilks's Lambda, which measures the deviations within each group with respect to the total deviations. The sample splitting method included initially the variable that most minimized the value of Wilks's Lambda, provided the value of F was greater than a certain critical value (i.e., $F = 3.84$ to enter). The next step was pairwise combination of the variables with one of them being the variable included in the first step. Successive steps were performed in the same way, always with the condition that the F-value corresponding to the Wilks's Lambda of the variable to select has to be greater than the aforementioned "entry" threshold. If this condition was not satisfied, the process was halted, and no further variables were selected in the process. Before including a new variable, an attempt was made to eliminate some of those already selected if the increase in the value of Wilks's Lambda was minimal, and the corresponding F-value was below a critical value (i.e., $F = 2.71$ to remove). Wilks's Lambda, canonical correlation index, and percentage of subjects correctly classified.

Results and discussion

The results show high performance prediction level of the DA models in the three categories (92,3%, INF; 90%, CAD; and 85,7%, JUV) (Table 1). The results are in line with those obtained by Mohamed et al (2009). These values are lower than those reported in young handball players (Fernández, Vila, & Rodríguez, 2004).

Table 1. Predictive capacity of multivariate models (discriminant analysis) developed from the multidisciplinary evaluation of young female handball players (n= 91).

Multidimensional evaluation	13-14 (INF)	15-16 (CAD)	17-18 (JUV)
All discriminant functions and variables included			
Canonical correlation index	0.74	0.74	0.87
Correctly classified (%)	92.3	90.0	85.7
First discriminant function included only			
Canonical correlation index	0.53	0.56	0.65
Correctly classified (%)	70.0	68.8	58.6
Variables entered	Abalakov jump Team sport first played: sport team Standing long jump Training sessions/wk Trochanterion height Simultaneous sports Abdominals (1 min) Hand length Age at beginning of sports participation Horizontal jump	Standing long jump Hand dynamometry Mesomorphism Abalakov jum Shuttle run endurance	Biacromial breadth Training sessions/wk Sit & reach Abdominals in 1 min. Arms flexion Injuries Squat Jump Hand width

The results show high performance prediction level of the DA models in the three categories (92,3%, INF; 90%, CAD; and 85,7%, JUV). The results are in line with those obtained by Mohamed et al (2009). These values are lower than those reported in young handball players (Fernández, Vila, & Rodríguez, 2004).

Conclusions

Altogether, these results support the notion of the multidimensional nature of this sport. The best age for talent detection based on this type of multidisciplinary evaluation seems to be 15-16 years of age (CAD category), when coordinative and cognitive factors probably begin to play an increasingly important role in handball performance.

One practical implication may be deduced: power should be considered not only as capacities which guarantee long-term athletic development, but also as predictors of performance itself.

E-mail: hvila33@gmail.com

PROPRIOCEPTIVE TRAINING IN HANDBALL

Prof. Dr. Alexandru ACSINTE

University "Vasile Alecsandri" from Bacau – Romania

Summary:

Proprioception is the body's ability to get information to the brain in response to a stimulus arising within the body; it also refers to the body's ability to sense the position of its limbs at any moment. For example, an athlete who has gone airborne and then lands on an opponent's foot may injure his/her ankle if his/her brain does not sense that he/she is landing on someone's shoe and not the floor.

Keywords: handball, training, proprioception.

Introduction:

It is well-known that contemporary handball is much tougher, faster and more complex than the one played in the 1990's. Compared to that period, the body contact and time playing strength are far more powerful. It must be emphasized that these changes in the game dynamics (performance speed, attack development, technical complexity of the performance etc) have an effect on the body, by subjecting it to great physical stress.

Some of the previously emphasized aspects are the subject of many statistical studies, following important international events (EUCh, WCh, OG), studies that were individualized on certain game sequences (Taborsky F., Pollany W., Holdhaus H. etc).

The most common of all ankle injuries, an ankle sprain occurs when there is a stretching and tearing of ligaments surrounding the ankle joint. The numerous ligaments around the ankle can become pulled and torn when the ankle is forced into a position not normally encountered.

Some of the causes of an ankle sprain is applying weight to the foot when it is in an [inverted](#) or [everted](#) position. Commonly, this happens while running or jumping on an uneven surface. The foot rolls in (inversion) or out (eversion) and the ligaments are stretched. Occasionally a loud "snap" or "pop" is heard at the time of the sprain. This is usually followed by pain and swelling of the ankle. Pain caused by sprained ankles, and a variety of other injuries common to highly trained athletes, often have nothing to do with strength. They often have little to do with flexibility. And rarely do they have anything to do with endurance. More often than not, sprains and strains have to do with balance. Proprioception, to be exact.

The term **proprioception** refers to a sense of joint position. Proprioception training is highly common in rehabilitation of injured athletes, but it can just as easily be used to prevent injury. At the same time proprioception it refers to the capacity of the body to determine where all of its parts are positioned at any given time. Proprioception is like an on-board computer that complements conscious efforts to stabilize everything whether you are moving or standing still. It triggers muscles to contract and relax to fit the situation. It even factors in speed and direction of movement. A perfectly working sense of proprioception helps us perform better in sports and avoid injuries.

Even a strong ankle can sprain when running on uneven ground if the runner hasn't trained the neuromuscular system to react appropriately. Slight deviations in terrain require slight adjustments of balance to avoid injury (Elizabeth Quinn, 2008).

This physical stress also determines an increase in the number of injuries in top handball players (Hans Holdhaus, Manavis K & col.), and in this case, we can say that the ankle is one of the most exposed joints.

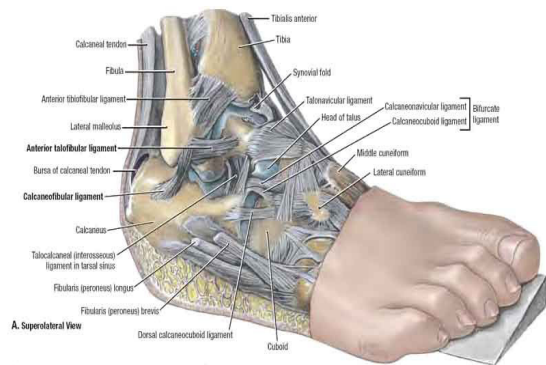

B. Lateral View

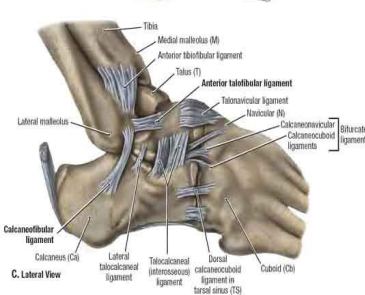

C. Lateral View

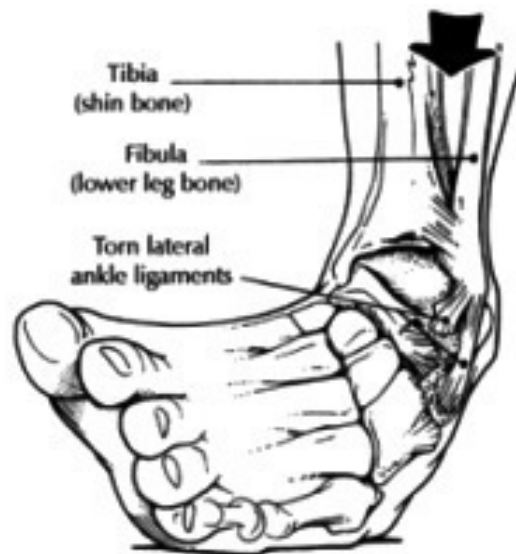

Proprioception is the body's ability to get information to the brain in response to a stimulus arising within the body; it also refers to the body's ability to sense the position of its limbs at any moment. For example, an athlete who has gone airborne and then lands on an opponent's foot may injure his/her ankle if his/her brain does not sense that he/she is landing on someone's shoe and not the floor. (Lorin A. Cartwright, William A. Pitney, 2005).

The term of proprioception refers to a sense of joint position. Proprioception training is highly common in rehabilitation of injured athletes, but it can just as easily be used to prevent injury. Even a strong ankle can sprain when running on uneven ground if the runner hasn't trained the neuromuscular system to react appropriately. Slight deviations in terrain require slight adjustments of balance to avoid injury. (Elizabeth Quinn, 2008).

We also have to mention the fact the conjuncture factors are equally important during a match, respectively, the desire to execute motor structures with a high degree of technical complexity in critical situations during the game, meaning the last seconds of the game, or extraordinary psychological pressure (Pollany W., Constantini D., Pokrajak B), pre-passive, numerical inferiority (Juan de Dios Roman Seco) etc.

Because an athlete may have deficient proprioception due to an injury, many Athletic Trainers believe that proprioception should be addressed in the early stages of a therapeutic exercise program, and thus many rehabilitation programs emphasize early proprioceptive training.

Proprioception training can be started early in a therapeutic exercise program by doing such things as balance or coordination exercises (Lorin A. Cartwright, William A. Pitney, 2005).

- The drills presented in this material, to be used during training sessions, can be approached also from different perspectives.
- The biochemical and physiological aspects have a determining role for a successful athletic technical performance, even if, apparently, their influences are insignificant (Alexandru Acscinte, 2004).
- Thus, the ideomotor representations, the body scheme, the self confidence, all viewed through the theories expressed in *Imagery in Sport*, can lead to the following aspects.

If we consider the simplest performance using the Balance Fit (BF), that is standing in a balanced position with both feet on two BF, apparently this does not strain too much the individual's abilities, no matter the personal motor experience, or sports branch they are currently practicing.



But when this drill is performed with eyes closed, things get a little complicated. In this kind of situation, different components spring into action for maintaining the body in balance, and other analyzers are strained, such as the vestibular analyzer and the proprioceptive elements, not just the eyesight.



It may seem weird, but during performances with eyes closed, even hearing appears to have an important role in maintaining balance, especially when the drill is performed in the company of other team-mates, or partners. Repeating this kind of drills alternatively with eyes opened and closed, leads to the creation of ideomotor schemes that help the athlete to get faster into a balanced position, in both circumstances.

Why do we need these drills to be performed with eyes closed?

Mainly to increase the accuracy and quality of the performances. As mentioned by specialists (Schmidt, quoted by Tony Morris, Michael Spittle, Anthony P. Watt, 2005, page 128), the professional athletes receive and process large quantities of information quickly and accurately, in order to monitor and adjust their performances.

The same authors (Morris, Spittle, Watt, 2005) mention that “visual imagery” is “seeing” the performance, or being instructed to picture your self the performance.

As a consequence, the kinaesthetic and proprioceptive information (position of the body, the degree of contraction of certain body segments, the trajectory of the performances, even the relation with certain objects) received by the athletes are of real use to them in accomplishing top-notch performances.

Methods:

During six months we conducted a study in the First Romanian Male Handball League, consisting in:

- introducing a set of six proper balance exercises using Balance Fit devices in the first part of the training session;
- at the end of the training sessions we introduced the same set of exercises, but performed with eyes closed.

The studies we conducted on Team Handball goalkeepers have shown that even simple dynamic drills (e.g. jumps from the floor on the BF discs) can be performed with eyes closed, after these drills had been internalized and became automatic during normal training conditions.

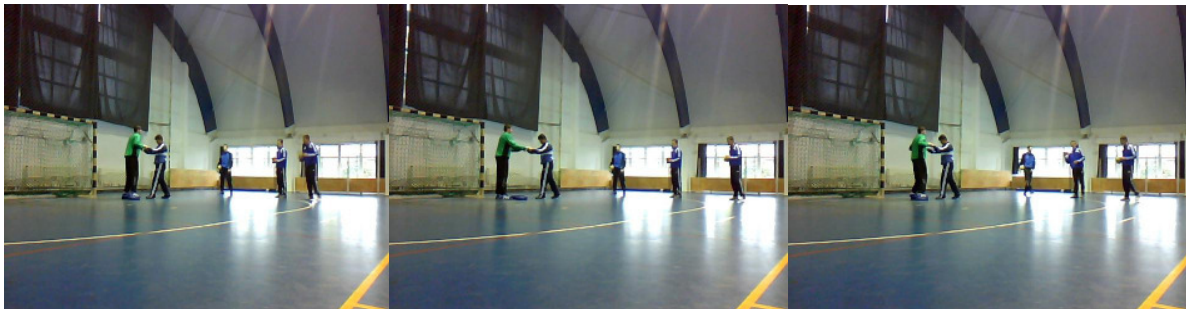

This protocols has been repeated according to the weekly competition programme, meaning minimum three sessions per week and maximum five sessions per week.

Results:

If we take into account the perspectives from which the *Imagery inSport* can be approached, Internal and External Imagery, respectively, then things can get complicated or simple, depending on the psycho-physiological potential of each athlete. In our case, the researches conducted on professional Team Handball players proved that the specific Internal Imagery representations, in goalkeepers, had a significant influence, especially during the 7-meter throws.

In the case of court players, several effects stood out:

- For the 9-meter line players (Left Back, Right Back and Central Back), the External Imagery proved to be more effective in making the game more fluent in attack.
- For the 6-meter line players (Left Wing, Right Wing and Pivot), the Internal Imagery influenced in a positive way their performance during attack, and especially the wings' performance during fast-break.

These aspects encourage the use of technical drills during special conditions in various specific structures of certain sports branches, the above-mentioned successes contributing to a

boost in the athletes' self-confidence and to a stimulation of their personal motivation (Rainer Martens, 2004, Tony Morris, Michael Spittle, Anthony P. Watt, 2005.)

Particularized to Team Handball, these facts have proven their applicability from multiple specific coaching points of view (A. Acsinte, 2009). All these drills (stimulating proprioception in special conditions—on mobile surfaces, BF, Wobble board, balance board etc.), performed in a particular manner (with eyes closed), can contribute to an increase in the quality of athletic performance, especially during game situations with a high psychological stress (the end of a match, a tie-in, the team/athlete being qualified for a superior phase in a competition, numerical inferiority situations etc.), as well as during situations demanding technical performances in unnatural body positions (unbalances in the air, passes, throws, hitting the ball from a fall determined by a rough action from the opponent etc.)

Conclusions:

- Handball player abilities (as, balance, neuro-muscular coordination, agility) could be improved using balance fit devices during training sessions;
- Some of the exercises could be adapted to each player particularities;
- Not all the players could perform all the structures (exercises) at a higher standard from the beginning;
- We recommend that at least the simple drills (the walk, the lunges and the simple jumps using both legs) to be performed with eyes closed.

alexandruacsinte@hotmail.com

HANDBALL TEAM STAFF HEART RATE MONITORING DURING WOMEN'S CHAMPIONS LEAGUE MATCH

¹Marta BON, ²Mitja BRAČIČ, ¹Marko ŠIBILA, ¹Primož PORI

¹Faculty of Sport, University of Ljubljana; ²Institute of occupational safety, Center for Medicine and Sport, Ljubljana, Slovenia

Summary

The aim of the study was to analyze the heart rate of members of the coaching staff (head coach, two assistant coaches, (age 36 ± 3.39 years, height 178 ± 6.86 cm, body mass $83,3 \pm 5.23$ kg). We analyzed the values of 5 matches; one very important match between HC Győr and HC Krim Mercator and three matches in the regional league and one training/friendly match. The heart rate (HR) was recorded at one-second intervals using the Polar Team System 2 (Polar Electro, Finland). It consisted of an electrode belt which recorded ECG signals without a wristwatch. The data stored in the belt was transferred to a PC and processed using the Polar Team² software during the matches. Based on the data obtained from the coaching staff, the program displayed the heart rate trace (beats/min) and automatically estimated energy expenditure (kcal) with the reference to each individual's data. The energy expenditure amounted to 476.0 ± 258.9 kcal. The mean value of the heart rate for all the matches was 96.4 ± 17.36 beats/min and the average $87,9 \pm 8,5$ beats/min. The maximum recorded heart rate was 145 (head coach), the max HR in all matches was $119, 2 \pm 12,6$ beats/min.

The values of HR and energy expenditure of the head coach are higher than for both assistant coaches. Importance of the match has a big influence on the values of HR and energy expenditure

Keywords: *handball, match, heart rate, coach*

Introduction

In recent decades, there has been an increasing amount of research activity in the field of coaching science (Gilbert & Trudel, 2004). Whereas most studies have focused on the behaviour and performance during the practice sessions, only a few have studied the coaches during actual competitions (Smith & Cushion, 2006), where performance is most relevant. Sports that permit a variety of intervention options during a match, confront coaches with a variety of problems that make major demands on their processing of information (Lyle, 2002).

Horton, Baker, Deakin (2005) examined various behaviors of five Canadian National coaches across three team sports in order to determine the central elements of their practice environment. Each coach was observed over multiple practice sessions that took place in a centralized training camp environment prior to an international competition. A modified version of the Coaching Behavior Recording Form was used to record both, frequency and duration across all coaching behaviors. In addition, qualitative data were derived from open-ended interviews with both coaches and athletes. The results confirmed that instruction constituted the majority of coaching behaviors. More importantly, tactical instruction was found to be the dominant form of instruction. Notable differences between the measures of frequency and duration were evident for Tactical Instruction and Praise/Encouragement. Results support the notion that expert coaches construct practice in a manner that maximizes the transfer of information to their players. In our study, we aimed to analyse also the psychological demands of coach. Actually, the physiological demands of team-based field sports have previously been described using heart rate (in football: (Bangsbo, 2007; handball: Bon, 2003; Bracic, Bon, 2010) blood lactate

concentration (Bangsbo et al.,2007) and estimate soft otalenergy expenditure (Bangsbo,2007). Heart rate recorded during match-play can be used to describe the intensity and also to estimate energy expenditure when comparing an individual's heart rate–oxygen uptake ($V \text{ VO}_2$) relationship (Bangsbo,2006). This information can provide important information on the intensity of competitive match-play as well as dietary requirements before, during and after a match. This applies to the players, playing on the playing court. Studies examining the physiological demands of handball league have described the game as a collision sport that requires a combination of high muscular strength, power and flexibility as well as high aerobic and anaerobic capacities (Bracic, Bon, 2010; Bon, 2003). Similar study was done by Gazes Broadus, Sovell, Dellastatious Colonel (1969) who have prepared an experimental and laboratory report about continuous radio electrocardiographic monitoring of football and basketball coaches during games. Thirty football and basketball coaches were monitored continuously with a radio-telemetric monitoring device throughout the games in which their teams competed. All responded to the stress of the game with an increase in heart rate averaging 42 beats per minute over resting rates in the pregame period and with an additional increase of 21 beats per minute during the game period. Eight coaches developed rare premature ventricular beats and in two cases they were frequent. The only coach with a known coronary disease had multifocal premature ventricular beats. Eleven coaches developed rare premature atrial beats and in one case they were frequent. A short run of atrial tachycardia occurred in one coach. None of them developed symptoms or significant S-T, T, or QRS changes. This method and research provide a wealth of information on the operation of coaches. In our study, we try to examine the physiological demands of handball coaches during official games on a high level, such as the champion league in the year 2010.

METHODS

Subjects

Coaches of women's handball club Krim Mercator Ljubljana (Slovenia) participated in experimental protocol (age 36 ± 3.39 years, height 178 ± 6.86 cm, body mass $83,3 \pm 5.23$ kg).

We analysed 3 coaches during (x number) of games . We divided the matches in three different levels of importance (expert decision): (CHL: CHAMPIONS LEAGUE; FM: FRIENDLY MATCH; REG: REGIONAL LEAGUE).

Procedure

An experimental procedure was developed to determine the heart rate of the coaching staff. The heart rate (HR) was recorded at one-second intervals using the Polar Team System 2 (Polar Electro, Finland). It consisted of an electrode belt which recorded ECG signals without a wristwatch. The data stored in the belt was then transferred to a PC and processed using Polar Team² software. Based on the captured data, the program displayed the heart rate trace (beats/min) and automatically estimated energy expenditure (kcal) for each individual.

RESULTS

Heart rate

Based on the recorded data, the program displayed the heart rate trace ($\text{beats} \cdot \text{min}^{-1}$) and automatically estimated energy expenditure (kcal) for each individual.

The mean value of the heart rate for the coaching staff during all five matches was $87,9 \pm 14,1$ $\text{beats} \cdot \text{min}^{-1}$. The value of maximum heart rate was $119,2 \pm 16,2$ beats/min. The energy expenditure amounted to $476,1 \pm 265,6$ kcal.

Table 1: Heart rate of coaches during a handball match.

NAME	FUNCTION	HR _{MAX}	HR _{AVER}	K _{CAL}	MATCH	LEVEL	IMPOR TANCE
BON	HEAD COACH	128	93	261	BUDUČNOST (MNG)	CHL	2
BON	HEAD COACH	145	117	1069	GYOR (Hungary)	CHL	1
BON	HEAD COACH	96	81	650	HYPO (AUT)	CHL	2
BON	HEAD COACH	117	92	442	PLEVLJA (MNG)	REG	3
BON	HEAD COACH	119	89	512	PLEVLJA (MNG)	REG	3
BREGAR	ASSISTANT COACH	107	71	356	BUDUČNOST (MNG)	CHL	2
BREGAR	ASSISTANT COACH	139	102	693	GYOR (Hungary)	CHL	1
BREGAR	ASSISTANT COACH	97	74	296	PODRAVKA (Croatia)	FM	3
ŠTERBUCL	ASSISTANT COACH	128	85	244	BUDUČNOST (MNG)	CHL	2
ŠTERBUCL	ASSISTANT COACH	116	75	238	PODRAVKA (Croatia)	FM	3
	AVERAGE	119,2	87,9	476,1			
	STDEV	16,4	14,1	265,6			

*CHL: CHAMPIONS LEAGUE; FM: FRIENDLY MATCH; REG: REGIONAL LEAGUE

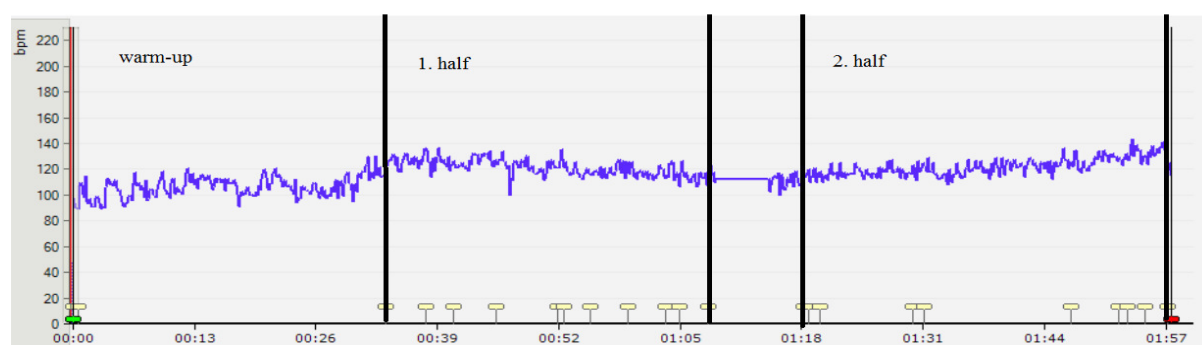

Figure 1: Heart rate curve of head coach between the match.

		HR	Time in sport zones					Above threshold	Training load	Kcal		
			Minimum	Average	Maximum	50-59	60-69				70-79	80-89
21 MARTA BON	01:57:33	85	117	145	00:19:36	01:11:16	00:20:50	00:00:05	00:00:00	00:00:00	101	1069
Max HR: 180		47%	65%	80%	16,7%	60,6%	17,7%	0,1%	0,0%	0,0%	100,0%	100,0%

Figure 2: Heart rate zones of head coach during the match (Plevlja, regional league).

Figure 1 and figure 2 demonstrate an example: game HC Plevlja (MNG) was not very demanding as it was clear that HC Krim is the stronger team. Average HR on both games playing in regional league (90,5 bits/min) was lower than on champions league games.

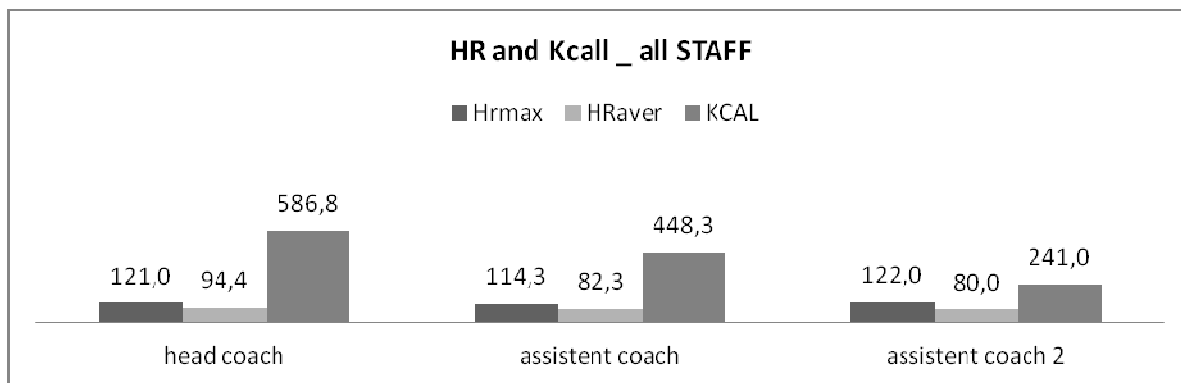

Figure 3: Heart rate and Kcall of all coaches during all matches

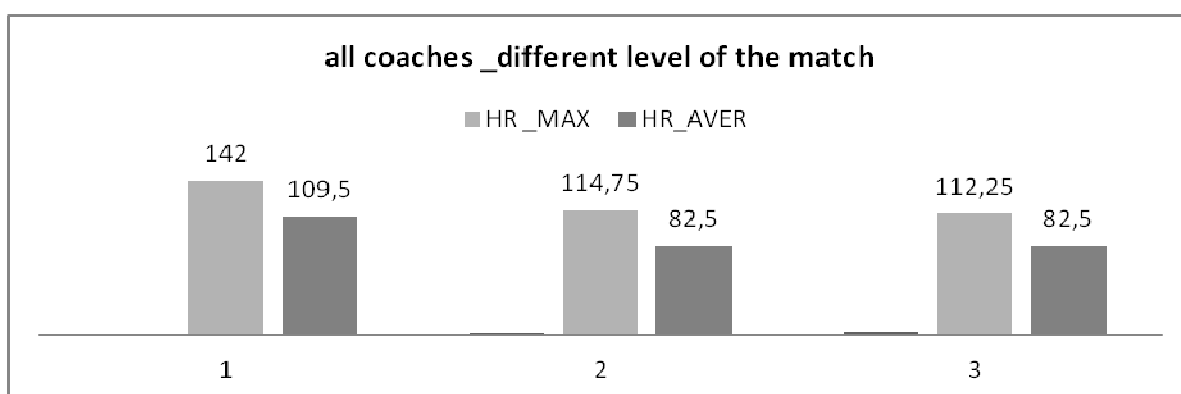

Figure 4: Heart rate of all coaches - three different levels (Importance) of the match

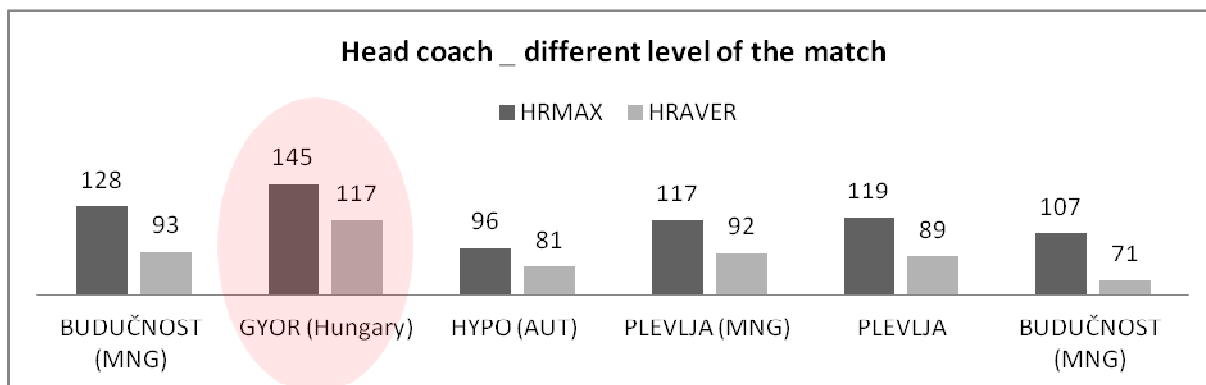

Figure 5 : Heart rate of head coach between the match on different level.

Results on Figure 3, 4 and 5 show differences in heart rates depending how important the game is for the team. The Game against Gyor (HR max; 145, average= 117) was an elimination game for both teams (Gyor and Krim Mercator); the winning team is going to play in the semi-finals of the Champions league in the season 2009/10. Other matches (level 2 and 3) have less importance for the future of the team.

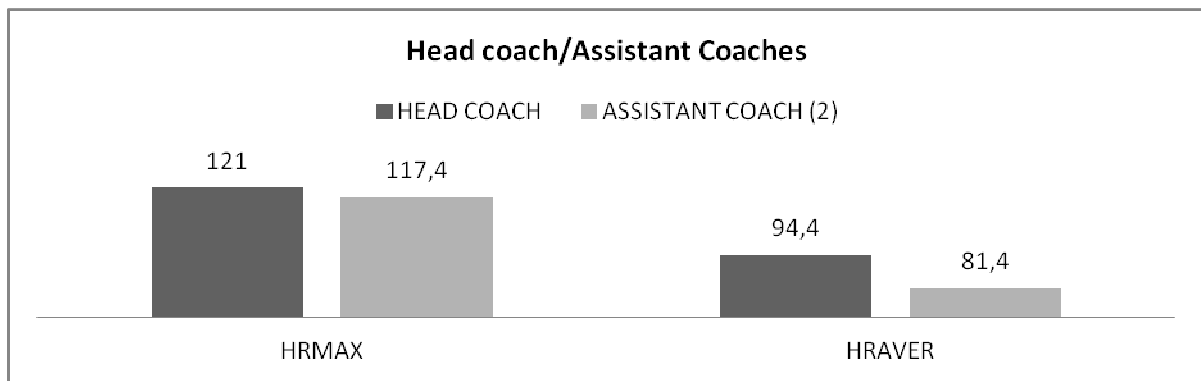

Figure 6: Comparative analysis: max. and average heart rate between different levels of the matches

Our results show big differences in physiological demands between the head coach and the assistant coaches (figure 6, 3, and 4). The head coach has a substantially higher average, with more than 10 bits higher values (94,4 bits/min) than both assistant coaches (81,4 bits/min).

CONCLUSION

In the last few years, there has been an increasing amount of research activity in the field of coaching science. In this study, we examined the demands placed on coaches during official competition matches in professional handball. We analyzed and compared the data across different levels of competition and across different positions on the team's coaching staff. The findings indicate that a game which is decisive for the team's ranking, has a considerably greater impact on physiological demands for all members of the coaching staff than a game which is not decisive. It is also conclusive that the head coach has a higher psychological burden than the assistant coaches. We suggest further research into the stress levels and psychological demands placed on the coaching staff during competition matches. It would be interesting to explore all other indicators (lactate, hormonal level) of the coaches' response to stressful situations in professional sports, and find appropriate anti-stress programs.

Marta.Bon@fsp.uni-lj.si

STUDY OF THE PROPORTION BETWEEN WOMEN AND MEN'S BALLS OF HANDBALL, AND THE MEASUREMENT OF THE HAND OF WOMEN AND MEN HANDBALL PLAYERS

Juan Fransisco OLIVER CORONADO (1) & Patricia Irena SOSA GONZALEZ(2)

- (1) Royal Spanish Handball Federation & Faculty of Sport, University Pablo de Olavide, Sevilla, Spain. Member of the Union of University Handball Teachers (UUHT) and IHF Lecturer.
 (2) Royal Spanish Handball Federation & Faculty of Sport, University Pablo de Olavide, Sevilla, Spain. Member of the Union of University Handball Teachers UUHT and EHF Master Coach.

Abstract:

The aim of the present study is to know the relation between the measures of handball players's hands and the measures of the balls in Under 14, Under 16 and Under18 age categories, women and men. Depending on the results, we will propose to the IHF to revise and modify the rule of ball's measures, men and women in each sport category, to be in accordance with the anthropometric characteristics of the hand of the players.

Keywords: handball, measures of balls, measures of hands, handballplayers

Method:

Participants:

The final sample of our study is formed by 1457 handball players of all Spain, both sexes, 755 men and 702 women, 13 to 18 years, All of them participated in the Championships of Spain of Territorial Selections of year 2010, in the categories Under 14, Under 16 and Under 18. (Table 1).

Table 1. General characteristics of the sample.

		N (1457)	Percentage of the sample %
Sport category	Handball	1457	100
Sex	Men	755	51.82
	Women	702	48.18
Age/Category	Under 14	492	33.77
	Under 16	499	34.25
	Under 18	466	31.98
Sport Category	Under 14 Men	239	16.40
	Under 14 Women	253	17.37
	Under 16 Men	253	17.37
	Under 16 Women	246	16.88
	Under 18 Men	263	18.05
	Under 18 Women	203	13.93

Measures:

The measurement is realised placing the hand on the milimetric paper, making place its thumb on the line of lateral beginning of the paper. Placed the thumb in that position and situation, it is requested to open his/her dominant hand as much as possible, trying to arrive more far possible, in relation to the thumb, with its little finger. Two marks with a ball-point pen one in the beginning, situation of the beginning of the distal phalange of the thumb, and another one

in the end, situation of the distal phalange of the little finger become.

Results:

Summary of the data: After studying all the data of the average of the cross-sectional measurement of the dominant hand of the sportsman in all the sport categories, Under 14, Under 16 and Under 18, male and female, table 2 picks up as a summary these data.

Table 2. Average, in centimeters, of the cross-sectional measurement of the dominant hand of the sportsmen, by categories and sexes.

Sport Category	Average of the cross-sectional measurement of the dominant hand
Under 14 Women	19,84 cm.
Under 14 Men	20,93 cm.
Under 16 Women	20,06 cm.
Under 16 Men	21,63 cm.
Under 18 Women	19,69 cm.
Under 18 Men	21,88 cm.

Analysis of the Results:

On the one hand it has been come to obtain the average of the cross-sectional measurement of the dominant hand of the sportsmen, grouped by sport category and sex. On the other, the central value has been taken from the rank, measured in centimeters, of the official size according to the Rules of Game I.H.F., of the circumference of the different balls from handball based on the sport category and sex of the sportsmen.

Interpretation of the Results:

The obtained results must be interpreted to be able to obtain the conclusions later. For it we will analyze each one of the results obtained in the different categories from ages (Under 14, Under 16, Under 18) in relation to the category of sex (male and female). It is forced to indicate that the proportions that are between rank $\pm 2.5\%$, are considered correct, that is to say proportional (correct), whereas those that they are outside that rank, $\pm 2.5\%$, is not provided that is to say, would be “no correct”. This proportion by equivalence with the used statistical significance level is chosen more than it is of 95%.

Under 14

The realised analyses it is come off:

1 That the proportion between the average of the cross-sectional measurement of the dominant hand of the sportsmen in the category Under 14 between sexes (94.79%) and the proportion between the central value of the rank, measured in centimeters, of the circumference of the different balls from handball according to the official size of the Rules of Game I.H.F., in the category Under 14 and sex of the sportsmen (92.72%) can be considered proportional, that is to say, is correct.

2 That “the ideal” ball of the feminine category Under 14 taking as bases of the comparison the measurement of the ball of the masculine category Under 14 would have to measure 52.13 centimeters, measuring the official, rules IHF, between 52/54 centimeters, reason why we can determine that the proportion is correct, since it corresponds to (98.36%).

3 That “the ideal” ball of the masculine category Under 14 taking as bases of the comparison the measurement of the ball of the feminine category Under 14 would have to measure 53.80 centimeters, measuring the official, Rules IHF, between 54/56 centimeters, reason why we can determine that the proportion although a little right are correct, because it corresponds to 97.82%, within interval 100% (+ -) 2.5%.

Under 16

Of the analyses we can conclude:

1 That the proportion between the average of the cross-sectional measurement of the dominant hand of the sportsmen in the category Under 16 between sexes (92.74%) and the proportion between the central value of the rank, measured in centimeters, of the circumference of the different balls from handball according to the official size of the Rules of Game I.H.F., in the category cadet and sex of the sportsmen (100%) can be considered non proportional, that is to say, non correct.

2 That “the ideal” ball of the feminine category Under 16 taking as Under bases of the comparison the measurement of the ball of the masculine category 16 would have to measure 51,00 centimeters, measuring the official, rules IHF, between 54/56 centimeters, reason why we can determine that the proportion is not correct, because it corresponds to very outer 92.73% at the interval, [97.5%; 102.5%].

3 That “the ideal” ball of the masculine category Under 16 taking as bases of the comparison the measurement of the ball of the feminine category Under 16 would have to measure 59.30 centimeters, measuring the official, Rules IHF, between 54/56 centimeters, reason why we can determine that the proportion is not correct.

Under 18

Of the analyses it is possible to be determined:

1 That the proportion between the average of the cross-sectional measurement of the dominant hand of the sportsmen in the category Under 18 between sexes (90,86%) and the proportion between the central value of the rank, measured in centimeters, of the circumference of the different balls from handball according to the official size of the Rules of Game I.H.F., in the Youthful category and sex of the sportsmen (93,22%) can be considered non proportional, that is to say, non correct.

2 That “the ideal” ball of the feminine category Under 18 taking as bases of the comparison the measurement of the ball of the masculine category Under 18 would have to measure 53.60 centimeters, measuring the official, rules IHF, between 54/56 centimeters, reason why we can determine that the proportion is not correct.

3 That “the ideal” ball of the masculine category Under 18 taking as bases of the comparison the measurement of the ball of the feminine category Under 18 would have to measure 60.53 centimeters, measuring the official, Rules IHF, between 58/60 centimeters, reason why we can determine that the proportion is not correct.

Conclusions:

From the interpretation of f the results, we can obtain the following conclusions picked up in Table 3.

Table 3. Comparison between the present ball of game and the “ideal” ball, the handball players, by categories and sexes. Proposal of balls.

Sport Category	We Play	We Would Have to Play	Result
Under 14 Women	51 centimeters	52.13 centimeters	CORRECT
Under 14 Men	55 centimeters	53.80 centimeters	CORRECT
Under 16 Women	55 centimeters	51.00 centimeters	NON CORRECT
Under 16 Men	55 centimeters	54.99 centimeters	CORRECT
Under 18 Women	55 centimeters	53.60 centimeters	NON CORRECT
Under 18 Men	59 centimeters	60.53 centimeters	NON CORRECT

juanoliver@grupoeurotec.es

RELEVANCE OF BIOLOGICAL AND BIOMECHANICAL ANALYSIS IN HANDBALL PERFORMANCE.

Paul DELAMARCHE & Benoît BIDEAU

Movement, Sport and Health Science Laboratory, University Rennes 2, E.N.S. Cachan, France.

Introduction

In recent years there has been a remarkable expansion of sport sciences. The topic is now recognized both as an academic discipline and a valid area for sportsmen and coaches.

The broad aim is to bring together scientists whose research work is directly related to handball and practitioners of handball interested in obtaining current information about the scientific aspects that are supporting the handball performance.

Handball is a very complex intermittent game.

This paper only focuses on some biological and biomechanical aspects of handball performance knowing that they contribute only for a part in team success. Anthropometric measurements, physiological, biological and biomechanical attributes, throwing velocity, strength and on-court performance are discussed. All these attributes can be advantageously used when planning adequate short and long-term training programmes able to enhance the team performance and to prevent individual injuries.

Anthropometric measurements

Height

Everybody knows that handball players are large and quite heavy while basket-ball and also volley ball players are taller. Nowadays the mean height of an elite handball player is about 1.90m. The height of handball players has increased from 1970 to 1990 but does not change since the last 20 years. This finding is not well understood. May be there is a mismatch between the motor abilities of the taller subjects and the complex engagement of motor and metabolic capacities that handball requires and current training remains still to be improved and adapted for such subjects. Wingers are usually smallest and backs tallest whereas pivots and goalkeepers are in the medium. The reasons of all these discrepancies also remain less understood. Many authors suggested that these specificities are related in part with the respective tasks of the court-players. For example, a high size gives an undisputable advantage to backs when blocking the opponents' shoots or when shooting at the goal over the defensive wall.

Hand length and arm span

Of course, the hand length and hand spread are important for ball control during the game. Although the ball size is quite different, there is no significant difference concerning the hand characteristics between basket-ball, volley-ball and handball. These findings probably reflect the specificity of each sport, in particular in the ball throw and manipulation. In Handball the hand and arm characteristics are correlated to throwing velocities. It has been reported that players who throw the ball at a higher velocity also have a wider arm span related to their body height (Skoufas et al. 2003). The ratio arm span/stature for elite athletes should be 1.05-1.06. Additionally the hand length should equal at least the ball diameter (Burton et al. 1992).

Body mass and body composition

Depending on the studies, the body mass of elite male adult handball players is close to 90kg. Therefore, the body mass index (BMI) (ratio between the body weight and the square of the height) is about 23. However the BMI is not a valid index of adiposity in sportsmen. Even if the indirect assessment of body fat from skinfold measurements can produce error rates of more than 2%, few studies have attempted to estimate body fat and fat free mass in handball players. The scarce values indicated that body fat is around 14%. In the study of Bayios et al. (2006) the team handball players were shorter, had a lower body mass, a higher percentage of fat and a lower fat free mass (FFM) than the basket-ball and volley-ball players. As a consequence, the somatotypes are quite different between these 3 sports. According to Bayios et al. (2006) the handball players are more mesomorphic, more endomorphic, and less ectomorphic than both basket-ball and volley-ball players. It may be assumed that mesomorphy helps team handball players to support body contacts and physical collisions which often occur in handball game.

In young as well as in female handball players, few studies only are available with regard to the anthropometric characteristics. However they lead to similar conclusions. As a consequence, many coaches include various anthropometric characteristics and especially a high size in the selection criteria for young elite handball players. However the relation between such characteristics and performance is being modified through different levels of maturation, as anthropometric characteristics are affected by heredity in different ways. As a result, some anthropometric characteristics, such as body stature, can be unreliable predictors of a future performance potential because of their high variability during puberty. Therefore, it is not safe to overestimate the anthropometric characteristics of junior players as predictors of their future anthropometric profile (William et Reilly 2000).

Field tests

Field tests are very much appreciated both by coaches and by sportsmen. They are suitable for investigating large population groups, require minimal equipment and have greater specificity to the sport. They also provide a familiar and less intimidating environment for players. Moreover, the advent of short-range telemetry and the design of lightweight portable apparatus have revolutioned applied sports science work. Heart-rate (HR) monitoring is now a routine procedure in field settings and as a gauge of maximal effort in performance tests. In contemporary handball player, physiological responses such as HR and blood lactate (BL) can be used to monitor and quantify intensity of training load (Delamarche et al.1987). Radio-telemetry of oxygen uptake is also feasible. The analytical equipment containing sensors for measuring gas concentrations and air-flow can be worn as a backpack. Using these devices in practical set-ups is more convenient than the traditional Douglas bag method. The latter system was used in elite male scandinavian handball players by Mikkelsen and Olesen since 1976 during training sessions and match play. However such studies remain scarce in handball.

The data highlight the high energetic requirement imposed by handball play. Most of the time, HR was comprised between 160 bpm and 185 bpm and sometimes reached values near maximal HR. The rectal temperature, an excellent index of the internal temperature reached values between 39°C and 40.5°C at the end of the match. Whereas blood lactate levels did not reach values beyond 4mM at the end of the game, Delamarche et al. (1987) observed much higher values between 9 to 13mM throughout the play. These results indicated that players must be trained to tolerate high lactate levels and be able to remove lactate to preserve their maximal efficiency throughout the game.

More recent studies provide new and interesting information which contribute to a better understanding of handball energetic requirement. Handball players usually cover a distance between 4.5- 6.5 km. Using a computerized match analysis system Luig et al. (2008) conducted time-motion analyses during nine games of the 2007 men's World Cup. Playing time was comprised between roughly 30 min to 40 min depending on playing position. The total distance covered by field players consisted of roughly 35% walking, 45% slow running, 18% fast running, and 3% sprinting. Compared with other players, wings covered significantly shorter distances while slow running but significantly longer distances while fast running and sprinting. The distances covered are a lot less of what was reported in the 80s and is possibly due to how the game has changed with a better use of substitutions during the game to make sure players can perform fast movements for almost 21% of the total distance covered.

Several authors (Lidor et al. 2005, Zapartidis et al. 2009) mentioned that sprinting velocity for short distances is an important element of performance in handball team. Players are required to cover distances between 10-20-30 m with maximal speed from the phase of attack to the phase of defence after a ball loss, or in order to prevent a fast break. To explore the speed capacities, the time to realise a 30 m sprint was measured and found between 3.8 - 4.4 s⁻¹. The best performance was obtained by wings. The high intensity of the handball game is also expressed by the great number of ground contacts per unit of time, as shown by Delamarche et al. (1987). All these findings stress the importance of the power and speed capacities in modern handball. Although only scarce studies are available in females or in young handball players, similar conclusions emerge.

Data obtained from field testing probably provide a better indication of the ability to perform in competition than a laboratory-based evaluation. However, the identification of the relevant energy systems which contribute to how the player will perform are not always straightforward due to the limited amount of physiological data yielded from field testing. This restriction in interpreting associated mechanisms may require complementary testing within a laboratory environment

Laboratory studies

In laboratory, evaluation includes a battery of tests measuring aerobic fitness, anaerobic capacities, muscular strength and power.

Aerobic fitness.

In field sports a high level of aerobic fitness helps to sustain the work rates associated with team play, supporting team mates, running off the ball, and chasing opponents to regain possession. Whilst the aerobic contribution to single short-duration sprint is small, there is an increasing contribution during repeated sprint activities. Therefore aerobic capacity will aid recovery in the intermissions between the high-intensity exercise bouts. A good aerobic condition provides a platform of fitness for tolerating the strain of sport specific training and playing matches.

Maximal oxygen uptake (VO₂max): The maximal ability to consume oxygen is established in a laboratory protocol whereby the exercise intensity is gradually increased until the individual reaches voluntary exhaustion. As locomotion is a feature of handball play, a running treadmill is the most appropriate ergometer for the assessment of participants. The exercise may be continuous or discontinuous. A common protocol is for 2-min stages after a warm-up, the velocity being increased by 2 km.h⁻¹.

In elite male handball players, the average values tend to exceed $55 \text{ mL} \cdot \text{kg}^{-1} \cdot \text{min}^{-1}$ and sometimes $60 \text{ mL} \cdot \text{kg}^{-1} \cdot \text{min}^{-1}$ but the variability is noticeable. This variation is due to positional differences playing styles, stage of fitness or age of individual players and tactical roles assigned to them.). For example, wings have the best and goalkeepers the lowest values (Zapartidis et al. 2009). No significant changes in mean VO_2max appear since the past 20-30 years despite significant changes in the shape and speed of the game. Such results might mean that though necessary, this attribute is not the one that makes and enhances the handball performance.

Endurance capacity: The upper level at which exercise can be sustained for a prolonged period is thought to reflect what is called the endurance capacity. As its direct assessment is highly time-consuming, sport scientists usually measure the “lactate thresholds (LT)” which are well related to the endurance capacity. These thresholds are determined from lactate responses to a submaximal test. The player runs at 6 to 8 different speeds on a treadmill, each for 2 min. A blood micro-sample (20 μ L) is drawn from a fingertip. After analysis, the relationship between blood lactate and running velocity is plotted and the 2 deflection points between lactate response and velocity are determined. This task is more difficult than calculating the exercise velocity corresponding to a fixed blood lactate concentration, such as 2mM or 4 mM. But there is no universally accepted method for the detection of LT. Whatever the method LT is expressed as the exercise velocity or sometimes as the corresponding value in oxygen uptake or heart rate.

The lactate response is reduced with endurance training as the individual improves in clearing lactate from the system and in producing less lactate within active muscles. A higher LT theoretically means that a field-games player could maintain a higher average intensity during a match without accumulation of lactate. However the lactate curve can also be affected by diet, the lactate curve moving to the left following carbohydrate ingestion (Reilly and Bryant, 1986). This shift might erroneously be interpreted as a detraining effect and therefore strict control over diet is advised when lactate responses are monitored.

Most studies indicated a good endurance capacity in elite male handball players (Delamarche et al. 1987, Rannou et al. 2001, Gorostiaga et al 2005, 2006.). Interestingly, works of Delamarche et al (1987) reported that high LT were associated with higher HR during game showing that high endurance capacity helps to develop and sustain intense work load.

Here also, data in young as well as in female handball players are still less numerous. Reported values for mean VO_2max are roughly between $50 \text{ ml min}^{-1} \text{ kg}^{-1}$ to $55 \text{ ml min}^{-1} \text{ kg}^{-1}$ in adult females (Jensen et al. 1997) or in elite young handball players (Zapartidis et al. 2009, Rannou et al., 2001)

Anaerobic capacities

As shown by field studies, competitive handball incorporates many intermittent high-intensity bouts of activity that may have to be repeated many times during the course of the match with little recovery time between efforts. The demands vary depending on the strength of the opposition, the level of the competition and the course of the game. Anaerobic metabolism is required when energy must be supplied at a faster rate than can be met by aerobic metabolic pathways. Even in laboratory, various tests have been designed for the determination of the anaerobic performance. The literature is replete with

assessments protocols for anaerobic performance meaning that that none is valid enough and can be considered as a good index of anaerobic performance. As a consequence, one must accept that a minimal battery of different and complementary tests is needed for assessing the anaerobic performance

Vertical jumping: The muscular power can be estimated by jumping on a force platform. This test has been validated as a means of assessing bilateral strength asymmetry in athletes. Jump devices can be combined with the use of high speed-camera systems using reflective markers placed on participants and allow jumping capacity to be assessed. However all these systems require relatively complex equipment, which are not available for routine assessments. They have been used in handball players by Thorlund et al. (2008) The production of power in vertical jumping can be calculated, knowing the player's body mass, the vertical distance through which body mass is moved and the flight time. The vertical distance itself is a good index of muscular performance, i.e. mechanical work done. According to the type of jump employed (for example, counter-movement jump with or without arm swing), the positions of the participant's arms and legs during flight must respect the individual protocol guidelines in order not to increase jump time or height artificially.

Wingate-test - peak and mean power: The Wingate test was originally designed at the National Institute of Israël from which it gets its name. It is performed on an instrumental cycle ergometer and consists in an all-out 30s exercise against a fixed braking-load. It allows power to be derived throughout the test so that the peak power as well as the mean 30 s-power developed can be measured. A blood microsample drawn from the fingertip 3min after the end of the test also allows to analyse blood lactate and the use of anaerobic metabolism. Interestingly results of Rannou et al. (2001) reported peak power values between $12.7 \text{ W}\cdot\text{kg}^{-1}$ to $16.5 \text{ W}\cdot\text{kg}^{-1}$ in national male handball players. The highest values were similar to those of male sprinters. As in sprinters, the blood lactate concentrations measured in handball players were as high as 15mM especially in players who were also the more active and efficient during game. Surprisingly Kalinski et al (2002) observed that peak power values achieved for players of basketball, handball, rugby, and volleyball all members of first league sports teams were similar when expressed per kilo of body mass. Values were exceedingly higher (20% - 25%) than values reported for apparently healthy, untrained males. Here also data remain scarce in young (Norkowski 2002).and female (Delamarche et al. unpublished data) handball players with peak power avlues comprised between $10 \text{ W}\cdot\text{kg}^{-1}$ to $12 \text{ W}\cdot\text{kg}^{-1}$.

Originally, the Wingate test has been adapted to explore the muscle power and anaerobic capacities of arms by Kounalakis et al. (2008). These authors found that the peak power was statistically higher in handball players than in control subjects ($7.6 \text{ W}\cdot\text{kg}^{-1}$ versus $6.7 \text{ W}\cdot\text{kg}^{-1}$).

Arm muscle strength and throwing velocity: One of the most important factor in handball performance is throwing ability. Throwing ability is itself a main determinant of the ball speed which can reach values as high as $86.6 \text{ km}\cdot\text{h}^{-1}$ in elite male handball players (Bayos et al. 2001). At last, the throwing velocity from a standing position for international male handball players ranges for $20\text{-}24 \text{ m}\cdot\text{sec}^{-1}$ (Gorostiaga et al. 2004). An interesting literature review on this specific topic has been recently published by Ziv et Lidor (2009). The authors mentioned the study of Bayos et al. (2001) which did not find any significant relationship between throwing velocity and the isokinetic strength of the shoulder rotators

suggesting that other factors such as lower extremity strength and trunk rotation might play an important role. According to Ziv and Lidor (2009) most studies examining throwing velocity did not look at throwing accuracy and this fact was a matter of concern. Other studies have assessed the contribution of training or detraining to increase or decrease throwing velocity in handball. Whereas a significant relationship was found between the total strength training time and standing throwing velocity (Gorostiaga et al., 2006), a significant reduction in throwing velocity was reported after 7 weeks of detraining (Marques et Gonzalez-Badillo, 2006).

Conclusion

Performance in handball is a complex composition of various dimensions which requires players to have well developed many capacities, including different physical capacities, motor ability, psychological, sociological, environmental qualities, technic and tactic, and so on... The role of the scientist is to match the characteristics of individuals to the demands of the sport. This is a complex problem in team sports where eventual success is determined by how the collection of individuals forms an effective unit performance. There are also elements of chance that determine the outcome of critical events and tilt the balance of the contest. This makes hard to relate the outcome of a particular match with some specific factors only.

Nevertheless, handball analysis can be approached from a scientific perspective. Clearly handball will take advantage from scientific knowledge and know-how coming from various scientific disciplines especially in the building of training programmes. It requires that sport scientists and practitioners work together in order to determine what might be the relative value of each parameter in the final performance and how it can be enhanced.

paul.delamarche@gmail.com

INFLUENCE OF BIRTH YEAR OF ARRIVAL AT ELITE HANDBALL MALE IN JUNIOR AND U 18's

Óscar GUTIERREZ AGUILAR¹, Julia CONTRERAS MARIN¹, Miguel SAAVERDA GARCIA², Juan José FERNANDEZ ROMERO², Alexandre ACSINTE³, Miguel HERNANDEZ, Iago VAZQUEZ GARRIDO⁴.

¹University (Elche, Spain), ²University A Coruña (A Coruña, Spain); ³University Bacau (Romania); ⁴University Alfonso X (Madrid, Spain).

ABSTRACT

The handball world championships, organized by the International Handball Federation (IHF), for Juniors and U18's category, establishes the groups of contesters, on the adscription of athletes born during two consecutive years in the same category, starting with those born in even-numbered year, and must stay two consecutive years in the same category. The sample is composed by 686 handball players, which have played the World Championship of their category on 2009. The recorded variables were the birth year. The differences between the proportion of players born in even-numbered year than the ones which were born in odd year, was calculated by the binomial test, contrasting the proportion of 50%. In Junior and U 18's category they have been found much more players born in even-numbered years than in odd years, which very big significant differences.

Keywords: Handball, relative age effect, talent detection.

INTRODUCTION

The firsts studies that exist about RAE, were done by Grondin Deshaies & Nault (1984), referring to the Canadian ice hockey and volleyball, even though most of all the researches are referred to soccer (Ashworth & Heyndels, 2007; Helsen, Starkes & Van Winckel, 1998; Helsen, Van Winckel & Williams, 2005; Jullien, Turpin & Carling, 2008; Musch & Hay, 1999; Serovic, 2005; Verhulst, 2000). All of these researches about soccer determinate if there is an influence of the birth date, due to the sport effort of the players in formation stages. It has been also analyzed RAE in another sports, that is how it is possible to find researches on baseball (Thompson, Barnsley & Stebelsky, 1991; 1992), hockey (Adonna & Yates, 2010), swimming (Baxter-Jones, 1995), tennis (Edgar & O'Donoghue, 1995) and rugby (Abernethy & Farrow, 2005).

The most used explanation to justify RAE, is the maturation process of sport people, on the who, the ones born near to the cutoff date have higher performance levels, compared to the youngest ones (Barnsley & Thompson, 1988; Malina, 1994; Malina, Bouchard & Bar-Or, 2004). The proposed solutions are often linked with the variation of the cutoff date, which means that RAE is modified, but it is not (Helsen, Starkes & Van Winckel, 2000; Musch & Hay, 1999; Simmons & Paull, 2001). Other solutions involve an enormous administrative complexity, like the one exposed by Barnsley and Thompson (1988), which said that the contesters selections should be set on a pre-establish distribution, or trough the control of the average age of the hole team Helsen *et al.* (1998; 2000). On handball there are just a few researches that analyze RAE; Schorer *et al.* (2010) analyzed the existent relations between motivation, relative age and the population. No differences were found in order to motivation. Although RAE was present in the hole sample, they did not found any distribution differences between the selected players and the ones not selected. They also did not found any relation between motivation, age and the size of the population.

Baker, Büsch, Wilhelm and Pabst work in 2009, with a sample of young German handball players established the existence of RAE. However they have proved that there were not any differences in height, weight or the technical skills between the players slightly older than the ones relatively younger, so that the RAE can not be attributed to these causes.

Schorer, Schorer, Cogley, Büsch, Bräutigam & Baker, (2009b) made an investigation which contains three different researches. The target of the first one was to determinate the influence of the level in competition and the genre in RAE. For this they used a sample of 1513 boys (13-16 years) and 1734 girls (12-15 years). On this research they established that RAE decreases as the levels grow and that in boys is less strong than in girls.

Second research analyzed the participation on the elite group, the nationality of the player and their permanence in the adult stage. They used a sample of 2291 players of the German first league and 4824 of the second league, among seasons 1998/99 and 2005/06. It seems that in foreign players exists higher RAE, this is explain by authors due to the stronger selection processes that players suffer to get into these leagues.

The third research took as objective relating the playing position and laterality with RAE in 1298 players of the first German league among seasons 2004/05 and 2007/08. Backcourt players suffer an important RAE. These players have to fulfill some anthropometric requisites, like being very tall and with big body size. Players which play in these positions are the ones in charge of long ball throws and there is a higher representation of players born on the firsts two trimesters of the year. Leftbacks are the ones who fulfill this statement, because in rightbacks, there are more born on the intermediate trimesters of the year. On the goalkeeping position, there are more number of players born on the first and last trimesters of the year, although on the pivot position there are more representation on the last two trimesters, and on central defenders on the middle trimesters.

The International Handball Federation (IHF) criterion used for the admission of contesters in junior world championships is based on the adscription of players born during two consecutive years in the same category, starting with those born in even-numbered year. During two seasons, same group of people stays in same category moving afterwards, this two year period has finished, all together to next category. With this method, players born in even years will be always the eldest of the generation, whereas those born in odd years will be the youngest of the group.

The point of this research is determinate if the birth date affects the possibilities of players, to get into the participation of Junior and U 18's international handball competitions.

METHOD

Samples and variables

The sample is composed of 686 handball players that have played the last Junior and U 18's World Cup in masculine category. These World Cups were played among 2009 and 2010. The registered variable was the birth date.

Data was taken from the web of the International Handball Federation (<http://www.ihf.info/>).

Data analysis

RAE analysis is normally done by taking the born trimester of the player as reference. In the present research, and due to the selection system of contesters on the World Cup Championships ruled by the International handball Federation, the reference was taken looking if the player was

born in even-numbered or odd year, because the ones born in even-numbered year will be the oldest ones of the group during two years, even in Junior or in U 18's category. The differences between the proportion of players born in even-numbered year than the ones which were born in odd year, was calculated by the binomial test, contrasting the proportion of 50%. On a similar way that Lesma Perez-González and Salinero (2011), RAE Coefficient is known as the division between the number of players born on the supposed advantage period, and the ones born on the supposed disadvantage period. This is correct, like in the present case, always if these time periods are the equal. On this research the RAE Coefficient represent the number of players born in even-numbered year (supposed advantage period) per each player born in odd year (supposed disadvantage period).

RESULTS

Differences per category

In Junior and U 18's category RAE coefficient was calculated in 1, 70 and 3, 19, (respectively), with very significant differences in both cases. On the Junior masculine side it has been proved that per each player born in odd year, there are 1, 7 players born in even-numbered year. On the U18's side, the tendency is more remarkable, as, per each player born in odd year, there are 3, 19 players born in even-numbered year.

		Frecuency	%	R.A.E. Coefficient. ¹	Significación*
Júnior Masculine	Odd	242	63	242/142= 1,70	0,000**
	Even	142	37		
	Total	384	100		
U18's Masculino	Odd	230	76	230/72= 3,19	0,000**
	Even	72	24		
	Total	302	100		

* Binomial Test.
 **Estadisticly significative.
¹RAE Coefficient is known as the division between the number of players born on the supposed advantage period, and the ones born on the supposed disadvantage period. This is correct, like in the present case, always if these time periods are the equal. On this research the RAE Coefficient represent the number of players born in even-numbered year (supposed advantage period) per each player born in odd year (supposed disadvantage period).

DISCUSSION

The existent researches about RAE try to determinate the effect of clustering people taking as reference the age of these ones. Generally the analysis is made by taking as reference the trimester where the person was born, starting on the hypothesis that the players born on the two fist trimesters of the year have more advantages over the younger ones, due to a higher level of maturation. However in the case of the international handball, players are grouped in categories (Junior and U 18's) beginning on the ones born in even-numbered years, so these will be the oldest ones of the group. On the same group the ones born in even-numbered year and the ones who do it on the next year, will remain during two seasons together on the same category, going trough the next category all the group together when that time period has finished.

There are several researches that have proved, on a same way that this research has done, the existence of RAE on the sport, during the formation categories. (Barnsley, Thompson, & Legault, 1992; Bäumlér, 2000; Baxter-Jones *et al.*, 1995, Gutiérrez *et al.*, 2010; Helsen *et al.*, 1998; Helsen *et al.*, 2000; Vaeyens, Philippaerts & Malina, 2005).

The fact that the criterion adopted by IHF, of clustering players on year blocks, reinforces even more the effect of RAE and gets closer to the researches that explain RAE by the maturation procedures (Fenzel, 1992; Helsen *et al.*, 2000; Malina *et al.*, 2004; Malina, 1994, 1999; Philippaerts *et al.*, 2006; Reilly, 2000; Simmons y Paull, 2001). Thereby Junior and U 18's national team coaches tend to select players born in the first year of selection (even numbered years), in order to having a more developed maturation system, a better anthropometric, physic and cognitive development could mean an advantage over the players born in odd year.

Among the solutions that several researchers have proposed for palliate this effect, this stand over the rest; change the cutoff date (Hurley, Lior & Tracze, 2001), set competitions with smaller age groups (Glamser & Vincent, 2004), or separate the players from the same category in order to their performance (Kaiserman, 2005).

Nevertheless all these propositions will crash with handball philosophy and with his biggest organizational identity, the IHF. Other proposition more suitable with the actual IHF line, respecting the criterions of the age as cutoff reference, for appaliate the effect of RAE on international high level handball competitions, during the formation categories, would be, as the same as García y Salvadores proposed (2005), permit that players change category at the end of the year, in a way that in one season the oldest of the group would be the ones born in even-numbered year, but next year, on the same category the oldest ones would be the ones born in odd year.

CONCLUSION

The data collected shows the existence of RAE on international handball players at Junior and U 18's masculine category. The system that IHF is running nowadays to organize their competitions, makes that players born in even-numbered year, have more chances of being selected at Junior and U 18's categories than the ones born in odd year.

PERPECTIVES

To reduce the existence of RAE in higher level competition of handball, on formation categories (Junior and U 18's), the International Handball federation should change the selection system of testers, in a way that every year, the oldest player of the group will change category. With this method, each season, groups will renew and the ones who were the youngest, next year would be the oldest ones. If things are done like that it is possible that this tendency (of selecting players born in even-numbered year over the ones born in odd year) from the people responsible of choosing the players will fall down, because this seems not to be a determinant criterion in the process of detecting talents.

ogutierrez@umh.es

INFLUENCE OF THE INTERPERSONAL RELATIONSHIP ON THE EFFICIENCY OF THE ATTACK FOR THE WOMEN HANDBALL TEAMS

Cezar HANTAU*, Florentina TONITA*, Andrei PASCAL*, Cristina HANTAU**

*National University of Physical Education and Sport; ** Academy of Economical Studies; Bucharest, Romania

Abstract

Due to the nature of university teams, to change the composition each year, we tried to see how the application of action methods (psychodrama and sociodrama) may influence the efficiency of the game in attack

Keywords: Psychodrama; sociodrama; attack; efficiency

Introduction

Handball teams are small groups. These groups are formed by persons who are in interaction and whose relations are influenced by individually recognized rules. These persons are following the achievement of one or more common objectives. In the same time the components of these groups are differentiated by roles, tasks and mentalities.

One of the university handball teams characteristics is that the components of these teams spend less time together and the components of the teams are changed each year.

Methods

The research methods used by us are: the sociometric questionnaire, the efficiency analysis of the attack game, the interview and the statistical analysis.

The research development

The initial tests were organized after four weeks after the reunion of the team, at the beginning of the university year 2010 – 2011. We used those four weeks to knowledge the new components of the team.

All research has spanned a period of six months, in this period we applied the action methods (psychodrama and sociodrama). In the same time, the technical and tactical practice took place in the same parameters as the previous year.

Research premises

- the players tested are representatives for the their category;
- the players are cooperative, participating at the team activities by 100% of their capacities;
- during the research the natural rate of progress was present.

Research purpose

The element of originality is represented by the use of the psychodrama methods in the psychological preparation of the women handball players. The purpose of our research is to see whether or how the interpersonal relationships may influence the efficiency of the players during the attack game.

Research hypothesis

Did the interpersonal relationships may influence the efficiency of the players during the attack game?

Working methods

Psychodrama is a therapeutic discipline which uses action methods, sociometry, role training, and group dynamics to facilitate constructive change in the lives of participants. Based on the theories and methodology of Jacob L. Moreno, M. D. (1889-1974), psychodrama can be found in mental health programs, business, and education.

Psychodrama is a method of psychotherapy in which clients are encouraged to continue and complete their actions through dramatization, role playing and dramatic self-presentation. Both verbal and non-verbal communications are utilized. A number of scenes are enacted, depicting, for example memories of specific happenings in the past, unfinished situations, inner dramas, fantasies, dreams, preparations for future risk-taking situations, or unrehearsed expressions of mental states in the here and now. These scenes either approximate real-life situations or are externalizations of inner mental processes. If required, other roles may be taken by group members or by inanimate objects. It is mostly used as a group work method, in which each person in the group can become a therapeutic agent for each other in the group.

Psychodrama's core function is the raising of spontaneity in an adequate and functional manner. It is through the raising of spontaneity that a system, whether an internal human system or an organizational system, can begin to become creative, life-filled and develop new solutions to old and tired problems or adequate solutions to new situations and concerns. A psychodrama is best conducted and produced by a person trained in the method or learning the method called a psychodrama director.

By closely approximating life situations in a structured environment, the participant is able to recreate and enact scenes in a way which allows both insight and an opportunity to practice new life skills. In psychodrama, the client (or protagonist) focuses on a specific situation to be enacted. Other members of the group act as auxiliaries, supporting the protagonist in his or her work, by taking the parts or roles of significant others in the scene. This encourages the group as a whole to partake in the therapeutic power of the drama. The trained director helps to recreate scenes which might otherwise not be possible. The psychodrama then becomes an opportunity to practice new and more appropriate behaviors, and evaluate its effectiveness within the supportive atmosphere of the group. Because the dimension of action is present, psychodrama is often empowering in a way that exceeds the more traditional verbal therapies.

Psychodrama seeks to use a person's creativity and spontaneity to reach his or her highest human potential. With its perspective on the social network in which an individual lives, it promotes mutual support and understanding. In explaining his work, Dr. Moreno stated psychodrama's goal: to make it possible for every person to take part in creating the structure of the universe which "cannot have less an objective than the whole of mankind."

There are several additional branches of psychodrama. Sociometry is the study and measure of social choices within a group. Sociometry helps to bring to the surface patterns of acceptance or

rejection and fosters increased group cohesion. This surfacing of the value systems and norms for a group allows for restructuring that will lower conflicts and foster synergistic relationships. Sociometry has been used in schools and corporations as well as within the mental health field.

Sociodrama is a form of psychodrama that addresses the group's perceptions on social issues, being a method for exploring the conflicts and issues inherent in social roles. Rather than being the drama of a single protagonist, this is a process that allows the group as a whole to safely explore various perceptions. Members might address different problems such as interpersonal conflicts (especially in a sports team), and together arrive at understanding and innovative responses to these difficult issues.

A sociodrama is a dramatic play in which several individuals act out assigned roles for the purpose of studying and remedying problems in group or collective relationships.

Sociodrama is similar to psychodrama in that both utilize group dynamics, enactment, and psychodramatic methods. They differ in the focus of the problem being addressed. Psychodrama deals with the problems that an individual person (i.e., “the protagonist) faces in dealing with real life situations. Those problems involve several levels—the general cultural milieu, the interactions of the social roles, and the particular forms those roles take in the real people involved. A person is a nexus of many roles and, more, in that process of coming together of many qualities, embodies a particular way he or she expresses each role and works out ways of integrating them. The problem is complexified by the fact that the individuals in the protagonist’s life are also particular people—not just roles—and so they play their roles in certain ways.

Some of the ways people play their role are consistent with how most people might expect that role to be played, but a fair amount of the interaction is also affected by idiosyncratic elements, certain qualities that express creativity, wisdom, foolishness, neurosis, quirks, and so forth.

Psychodrama addresses both the role conflicts and the individuality of the people playing out those issues. Sociodrama in contrast focuses on explicating the depth of complexity and conflicts at the level of the social roles involved.

Sociodrama acknowledges that it is worthwhile addressing these shifts, the issues associated with social roles in general. In certain situations it becomes worthwhile to examine the nature of various social roles and how they play out, how they interact with those in other social roles, or people from other cultures, and so forth.

Research results

When we analyzed the game we track the tactical combination made between two or three players. To compare this combination and action we made the following scale:

- 5 p – action completed successfully;
- 4 p – action finished by throwing;
- 3 p – action stopped by the adverse defense;
- 2 p – action interrupted by technical mistakes;
- 1 p – attempt to initiate an action.

The initial testing was done in the first six training games and the final testing was done at the Final Tournament of the University National Championships.

Action	The initial testing (no.)	The final testing (no.)
5p	86	128
4p	43	58
3p	48	36
2p	35	28
1p	42	31
Σ	254	281
average	42.3	46.8

Tab. no. 1 – The number of the action realised in the organised attack

Action	The initial testing (p.)	The final testing (p.)
5p	430	640
4p	172	232
3p	144	108
2p	70	56
1p	42	31
Σ	858	1067
average	143	177

Tab. no. 2 – The quality evaluation of the actions

Group:

The number of members participated in the sociometry testing: 10.

Group indices 1 (Sociometry test nr. 1)

Name	Description	Value
Density	The index describes the density of inner relations in the group.	0.67
Cohesion	The index describes the strength of mutual attraction of sportswoman in the group.	0.98
Stability	The index describes which minimal part of the group must be removed to divide the group to unrelated parts.	4.63
Tension	The index describes the value of dissatisfaction of clients by emotional relations in the group.	0.36

Group indices 2 (Sociometry test nr.2)

Name	Description	Value
Density	The index describes the density of inner relations in the group.	0.67
Cohesion	The index describes the strength of mutual attraction of handball players in the group.	1.47
Stability	The index describes which minimal part of the group must be removed to divide the group to unrelated parts.	4.88
Tension	The index describes the value of dissatisfaction of handball players by emotional relations in the group.	0.27

Conclusion

In technic-tactical terms we observe an increase of the number of the combination per game: from 42.3 to 46.8. The increase is not only quantitative but also qualitative. The number of 5p quoted action increase from 86 to 128, while the 2p (35 to 28) and 1p (42 to 31) quoted action decrease.

The index of cohesion, which describes the strength of mutual attraction of handball players in the group, and the index of stability (describes which minimal part of the group must be removed to divide the group to unrelated parts) increased after applying action methods in the team (cohesion, from 0.67 to 1.47, and stability, from 4.63 to 4.88).

These action methods (psychodrama and sociodrama) stimulated and encouraged the communication in a team, which led to a higher degree of cohesion and stability, and to a lower degree of tension in the team.

Analyzing the results of the technico-tactical tests and the sociometric tests, we are able to say that the increase of the cohesion and the stability index and the decrease of the tension index may influence the efficiency of the attack game.

c_hantau@yahoo.com

THE DIFFERENCES IN THE SELECTED MORPHOLOGICAL CHARACTERISTICS AND MOTOR ABILITIES BETWEEN THE SLOVENIAN HANDBALL GOALKEEPERS AND STUDENTS OF FACULTY OF SPORT

Igor JUSTIN, Maja PORI, Tanja KAJTNA, Primož PORI

Faculty of Sport, University of Ljubljana, Ljubljana, Slovenia

Summary

The object of the research is to present the differences in the selected morphological characteristics and motor abilities between the Slovenian handball goalkeepers who are members of the Slovenian First and the Second league of handball and students of Faculty of sport. The results show that Slovenian handball goalkeepers are taller, heavier and have less power of legs as indicated in some tests.

Keywords: handball goalkeepers, recreative population, morphological characteristics, motor abilities

Introduction

Handball players are placed on different positions in the field where certain specific abilities and characteristics are needed (Rogulj, Srhoj, Nazor, Srhoj and Čavala, 2005; Srhoj, Marinović and Rogulj, 2002; Šibila, 2004; Šporis, Vuleta, Vuleta, Jr. and Milanović, 2010). The most specific playing position in handball is a goalkeeper position where the main object is to save opponents' shots with the ball capable of reaching speed over 120 km/h (Bideau, Multon, Kulpa, Fradet, Arnaldi and Delemarche, 2004). The studies of the morphological characteristics and motor abilities of handball goalkeepers have included other handball players where comparisons between players of different playing positions or between players of different levels of performance have been made.

In the selection process the goalkeepers are usually recruited on the basis of increased height, weight, poor motor skills or on their desire to play the role (Šibila, Pori and Imperl, 2008). In order to achieve good competition performance, goalkeepers are required to express high level of many motor abilities too (Srhoj et al., 2002; Šibila et al., 2008).

It has been established that the elite handball goalkeepers should be tall and with long extremities enabling them to cover as much space on goalkeepers' area. The average male handball goalkeepers are taller than 190 cm and weigh over 90 kg (Srhoj et al., 2002; Šentija, Matković, Vuleta, Tomljanović and Džaja, 1997). Elite handball players and goalkeepers are, in comparison with non-elite players, predominately taller, heavier and have more body lean mass and less body fat mass (Gorostiaga, Granados, Ibanez and Izquierdo, 2005; Hasan, Rahaman, Cable and Reilly, 2007; Massuça and Fragoso 2011; Vasques, Antunes, Duarte and Lopes, 2005).

Some researchers focused on motor abilities of men handball goalkeepers. Zapartidis, Vareltsis, Gouvali and Kororos (2009) compared selected and nonselected young handball goalkeepers and established no presence of differences in the power of legs and arms, flexibility in backside of thigh muscles and back, running speed and endurance. Šporis et al. (2010) showed that elite handball goalkeepers were, compared with other players, the slowest in the team (running speed). Contrary Chaouachi, Brughelli, Levin, Boudhina, Cronin and Chamari (2009) discovered that elite handball players, on different playing positions, showed no differences in running speed, power of legs, endurance and strength of arms and legs.

The lack of literature concerning the analysis of differences in morphological characteristics and motor abilities between handball goalkeepers and sport recreative population is one of the

main reasons to carry out the present study. By means of the results it can be possible to evaluate the level of morphological characteristics and motor abilities of handball goalkeepers from another perspective that could reflect relevance of selection and training of handball goalkeepers.

Methods

Participants

The sample consisted of 46 healthy male handball goalkeepers, members of the Slovenian First and the Second league of handball (age: $24,2 \pm 5,2$ years; height: $185,6 \pm 4,9$ cm; body weight: $88,2 \pm 9,6$ kg; training experiences: $11,8 \pm 4,8$ let) and of a control group containing healthy male students of the Faculty of Sport in Ljubljana (age: $23,1 \pm 1,3$ years; height: $181,5 \pm 3,7$ cm; body weight: $77 \pm 8,4$ kg).

Variables

Morphological characteristics were assessed with 3 tests (4 variables were measured or calculated):

- Body height (BH) for assessing a longitudinal dimension (in centimeters);
- Body mass (BM) for assessing a voluminosal dimension (in kilograms);
- Triceps brachii skin fold (TBSF) for assessing body fat (in milimeters) (Marfell-Jones, Olds, Stewart and Carter, 2006).

BH and BM were used to calculate the body mass index (BMI) which is defined as the individual's body mass divided by the square of his or her height (in kg/m^2).

Motor abilities were assessed with 6 tests (10 variables were measured or calculated):

- Hip abduction (HAB) for assessing flexibility of hip structures (adductors) where we measured angle (in degrees) between the initial and the final position of the thigh (Pistotnik, 1991);
- Squat jump (SJ) for assessing power of legs (explosive force of muscles of legs) where we measured and calculated height (in centimeters) and energy (in Joules) of the jump (Bosco, 1999);
- Counter movement jump (CMJ) for assessing power of legs (explosive-elastic force of legs) where we measured and calculated height (in centimeters) and energy (in Joules) of the jump (Bosco, 1999);
- Drop jump (DJ) from 45 centimeters for assessing power of legs (explosive-elastic force of legs) where we measured and calculated height (in centimeters), contact time (in seconds) and energy (in Joules) of the jump (Bosco, 1999);
- One arm medicine ball throw (OAMBT) for assessing power of arm (explosive force of arm) where we measured a distance (in meters) of throw (Šibila, 1995);
- Lateral steps (LS) for assessing agility in lateral movement where we measured time (in seconds) to complete the drill (Šibila, 1995).

Statistical methods

The SPSS statistical package was used for statistical data analyses. Basic statistics for variables were computed. In order to determine differences between handball goalkeepers and control group an Analysis of variance (ANOVA) was employed. A probability level of 0.05 or less was taken to indicate statistical significance.

Results and Discussion

Basic statistical parameters and the results of Analysis of variance are presented in Table 1.

Table 1: Variables

Variable	G	X	SD	MIN	MAX	ANOVA (sig.)
Body height (BH) (cm)	G1	185,6	4,9	173	194	0,002* *
	G2	181,5	3,7	174	187	
Body mass (BM) (kg)	G1	88,2	9,8	68	113,5	0,000* **
	G2	77	8,4	66,5	103	
Body mass index (BMI) (kg/m ²)	G1	25,6	2,7	18,8	32,3	0,002* *
	G2	22,1	6,3	18,1	33,6	
Triceps brachii skin fold (TBSF) (mm)	G1	9,2	3,7	4	20	0,036*
	G2	7,2	2,4	4	12	
Degrees in a Hip abduction (DHAB) (°)	G1	66,1	10,5	43	90	0,445
	G2	63,9	8,1	47	80	
Height in a Squat jump (HSJ) (cm)	G1	33,5	3,6	24,1	39,3	0,000* **
	G2	38,1	6,8	31,1	46,2	
Energy in a Squat jump (ESJ) (J)	G1	288,2	38	207,6	367,6	0,993
	G2	288,3	52	226	403,7	
Height in a Counter movement jump (HCMJ) (cm)	G1	35,7	3,4	26,2	44,4	0,000* **
	G2	40,6	5,4	32,6	50,2	
Energy in a Counter movement jump (ECMJ) (J)	G1	307,1	37,9	225,8	415,4	0,972
	G2	306,7	53,9	230,5	413,7	
Height in a Drop jump (HDJ) (cm)	G1	33,2	5,4	23,9	50	0,002* *
	G2	37,8	4,3	31,1	45,5	
Contact time in a Drop jump (CTDJ) (s)	G1	0,22	0,04	0,16	0,33	0,295
	G2	0,21	0,02	0,17	0,25	
Energy in a Drop jump (EDJ) (J)	G1	287,4	40,4	214,6	369,9	0,981
	G2	285,8	51,3	218,1	400,5	
Distance in a One arm medicine ball throw (DOAMBT) (m)	G1	23,6	3,3	18,5	33,2	0,465
	G2	23	3,1	18	28,5	
Time in Lateral steps (TLS) (s)	G1	7,8	0,5	6,8	8,7	0,074
	G2	8	0,5	7,1	8,8	

Key: **GROUP 1 (G1)** – handball goalkeepers; **GROUP 2 (G2)** – control group; **X** - average value; **SD** - standard deviation; **MIN, MAX** - minimum and maximum values; **ANOVA (sig.)** – Analysis of variance (statistical significance - * p < 0.05; ** p < 0.01; *** p < 0.001).

It is evident that handball goalkeepers are, compared to a control group, statistically significant taller (BH), heavier (BM) and have higher BMI and TBSF. Results are quite similar to those where elite handball players and goalkeepers were compared with non-elite players and goalkeepers (Gorostiaga et al., 2005; Hasan et al., 2007; Massaça and Fragoço 2011; Vasques et al., 2005) with an exception of handball goalkeepers that, in our study, have

higher TBSF than a control group of students. That is similar to results of studies where handball goalkeepers had more pronounced skin folds (body fat) than the players from other playing positions (Srhoj et al., 2002; Šibila and Pori, 2009; Šporis et al., 2010).

Higher value of the BH primary helps goalkeepers to stop shots directed at the upper corners of the goal (Šibila and Pori, 2009). Handball goalkeepers also have higher BM and BMI that do not illustrate only the higher body lean mass but also the higher subcutaneous fat (TBSF). In SJ, CMJ and DJ the energy produced by participants was calculated. The energy depends on body mass and the initial velocity at the jumps ($\text{Energy} = \frac{1}{2} * \text{mass} * \text{velocity}^2$) (Enoka, 1994). Handball goalkeepers produce the similar energy as a control group but they have to move with more body mass, what results in a lower initial velocity and the height of the jumps. In the terms of body composition, in a case of a not very high level of strength and power, a faster reaction and movement can be expected when the body and limbs are not heavy due to the smaller moment of inertia (Enoka, 1994). Body fat can represent an additional burden. Muscle mass is desirable from the point of view of reaction and movement speed so far, until positive contribute to the speed and power of goalkeepers' movements. A high level of power of arms and legs in optimal combination with a body mass is assumed to be very important for the goalkeepers.

There are not any statistically significant differences between the handball goalkeepers and a control group in the results of the tests HAB, OAMBT and LS. As it can be seen from the results in LS, the handball goalkeepers are faster and yet not statistically significant. Lateral agility is important especially during the defense of shots from longer distances (Guitierrez-Davila, Rojas, Ortega, Campos and Parraga, 2011). Similar findings were reported by Šibila, Justin, Pori, Kajtna and Pori (2010) who investigated goalkeepers of different competition level and Zapartidis et. al. (2009) who compared selected and nonselected young handball goalkeepers. Šibila et al. (2010) reported that the only difference was in the test OAMBT where goalkeepers, who compete on higher level, achieved better results.

We measured the contact time in DJ where no differences between handball goalkeepers and control group have been seen. By equal time of taking off, students jump higher (HDJ), what can represents an advantage because, at the same time, they can reach a far more distant point. But handball goalkeepers are taller, so it is difficult to say who has an advantage.

Conclusions

Certain studies have shown that a condition of male handball goalkeepers is not at high level. The results of the present study in some way confirm the results of these studies. When compared to male students of Faculty of Sport, handball goalkeepers have less power of legs as indicated in some tests and the similar level of other abilities. The cause for such results can be the body mass, as handball goalkeepers are much heavier and have more subcutaneous fat. From the perspective including these abilities and characteristics, the students of Faculty of Sport have a better potential to be the handball goalkeepers. But handball goalkeepers have an advantage in body height; nevertheless it is hard to say who has a better potential from the aspect of morphological characteristics and motor abilities. In conclusion, a tall body and a high level of power of arms and legs in optimal combination with a body mass are assumed to be very important for the handball goalkeepers.

igorjustin@gmail.com

BALL SPEED IN WOMEN HANDBALL PLAYERS: ANALYSIS OF DIFFERENT PLAYING POSITIONS

Carmen MANCHADO¹, Carmen FERRAGUT², Arturo ABRALDES³,
Nuria RODRIGUEZ⁴, Pedro ALCARAZ⁴, Helena VILA⁴

¹University of Alicante (Alicante); ²University of Alcalá de Henares (Madrid), ³University of Murcia (Murcia); ⁴UCAM (Murcia). Spain.

Summary

The aim of this study was to describe the ball speed of different playing positions in female top-level handball players. 130 professional female players of the Spanish 1st handball league agreed to participate in this study. These data indicate that position-specific ball speed depends on the main throw that is performed most often during training and matches.

Keywords: Performance, team sport

Introduction

From the point of view of physical performance, handball is a complex, intermittent sport game, which requires maximum intensity efforts in a short period of time, where players jump, run and throw the ball at high velocity, followed by low intensity or rest moments (Jacobs, Westlin, Rasmusson and Houghton, 1982). Several studies have reported that, in handball players, in addition to the technical skills and tactics, the anthropometric characteristics, as well as high levels of force, power and throwing velocity constitute determining factors for the competitive success (Gorostiaga, Granados, Ibanez, Gonzalez-Badillo and Izquierdo, 2006; Gorostiaga, Granados, Ibanez and Izquierdo, 2005; Hoff and Almasbakk, 1995; Wallace and Cardinale, 1997). It is deduced as a result of all these studies that the physical prevailing requirements of handball are the explosive force in the upper and lower limbs (player velocity and throwing velocity of the ball) and the maximal force and muscular power (required in contact moves against the opponents) (Chelly, Hermassi and Shephard, 2010; Wallace and Cardinale, 1997).

Throwing velocity of the ball is an important skill in handball and a very important aspect for success (Fleck, Smith, Craib, Denaham, Snow and Mitchell, 1992; Gorostiaga, Granados, Ibanez and Izquierdo, 2005; Granados, Izquierdo, Ibanez, Bonnabau and Gorostiaga, 2007; Skoufas, Kotzamanidis, Hatzikotoylas, Bebetos and Patikas, 2003; Van den Tillaar, 2004). The velocity of a handball throw is not only dependent on the muscular strength, but other aspects like body segments coordination and technical skills (Van Muijen, Joris, Kemper and Van Ingen Schenau, 1991). This velocity is an important aspect for success, because the faster the ball is thrown at the goal, the less time defenders and goalkeeper have to save the shot.

The aim of this study was to describe the ball speed of different playing positions in female top-level handball players (centers, backs, wings, pivots and goalkeepers).

Methods

Subjects

130 professional female players of the Spanish 1st handball league (16 centre backs, 36 wings, 41 back players, 18 pivots and 19 goalkeepers) agreed to participate in this study. All of them were playing in the top Spanish professional handball league.

Assessment Procedures

The study was approved by the San Antonio Catholic University Committee for research involving human subjects. All participants received verbal and written information about the study and gave informed written consent before anthropometric and conditional assessment.

Throwing velocity test

Throwing velocity was assessed with a radar gun (StalkerPro Inc., Plano, TX, USA), with 100 Hz frequency of record and with 0.045 m•s⁻¹ sensitivity, placed behind the goal post and in a perpendicular direction to the player. This test has been shown to have very good test-retest reliability Intraclass correlation coefficient (ICC) of 0.96 and a coefficient of variation (CV) of 2.4% (9, 29).

Prior to the throwing velocity assessment, subjects performed a 15 min warm up focused on overhead throwing. After applying resin as desired, subjects performed two different protocols of throw, one with a goalkeeper and one without. For both protocols, subjects threw a standard handball as fast as possible towards a standard goal, using a single hand and their personal technique. The position or kinds of throws were: 1. 7m penalty shot (n=1); 2. Free throw from the 9 m line in a stationary position (n=2); 3. Throw from the 9 m line with 3 previous steps (n=3); 4. Jump throw from the 9 m line with previous running (n=4), all of them in straight direction to the goal in a random order.

Only throws sent to the goal post were used for analysis. For motivational purposes, players were immediately informed of their performance. A 3-minute rest elapsed between throws in order to avoid fatigue.

Statistical analysis

Standard statistical methods were used to calculate the mean and standard deviations. All data is expressed as mean \pm standard deviation (all data were checked for distribution normality and homogeneity with the Kolmogorov-Smirnov, Lilliefors and Levene tests). A one-way analysis of variance (ANOVA) together with a Tukey HSD post-hoc test was used to determine if significant differences existed among 5 playing positions (center, back, wing, pivot and goalkeeper). The $p \leq 0.05$ criterion was used for establishing statistical significance.

Results

The average velocity of each throws was: 21.44 m/s, 21.85 m/s, 23.47 m/s and 22.99 m/s for position 1, 2, 3 and 4, respectively. The players that reached the major speeds in throws 1, 2 and 3, were centre backs (22.28, 23 and 24.73 m/s respectively). In the fourth throw, the major velocity was for pivots with 23.60 m/s. Ball speeds differed significantly depending on the kind of throwing and on the player's main position. Highest values were reached either with 3 steps prior to throwing, or jumping. Pivot players reached the highest values jumping, while centre back players reached the highest values with 3 steps. Differences with (table 1) and without goalkeeper (table 2) are shown in the tables:

Table 1

Mean and standard deviations values ($\bar{x} \pm sd$) correspondent to throwing velocity with goalkeeper in m/s.					
Position	n	7 m (m/s)	9m (stationary) (m/s)	9 m (3 steps) (m/s)	9 m (jump) (m/s)
Centre	16	21.1 \pm 1.9	21.7 \pm 1.5	23.4 \pm 1.6	22.2 \pm 1.3
Back	36	20.5 \pm 1.4	20.9 \pm 1.7	22.2 \pm 1.9	22.1 \pm 1.8
Wing	41	20.0 \pm 1.4	20.2 \pm 1.3	22.1 \pm 1.4	21.5 \pm 1.2
Pivot	18	19.9 \pm 1.9	20.6 \pm 1.6	22.0 \pm 1.6	22.3 \pm 1.9
Goalkeeper	19	19.4 \pm 2.1	19.5 \pm 1.0	20.7 \pm 2.1	19.2 \pm 1.5
Total (m/s)	130	20.2 \pm 1.6	20.6 \pm 1.6	22.2 \pm 1.7	21.7 \pm 1.7

Table 2

Mean and standard deviations values ($\bar{x} \pm sd$) correspondent to throwing velocity without goalkeeper in m/s.					
Position	n	7 m (m/s)	9 m (stationary) (m/s)	9 m (3 steps) (m/s)	9 m (jump) (m/s)
Centre	16	20.8±1.42	21.1±1.48	23.1±1.10	22.5±1.59
Backs	36	20.9±1.68	21.0±1.57	22.9±1.88	22.3±1.59
Wings	41	20.3±1.64	20.5±1.55	22.1±1.7	21.8±1.42
Pivot	18	21.0±1.84	20.8±1.87	22.5±1.77	22.0±2.00
Goalkeeper	19	19.5±0.93	20.2±1.02	21.7±1.68	20.8±1.72
Total	130	20.6±1.63	20.7±1.55	22.5±1.74	21.9±1.62

Discussion

Throwing velocity in handball is important in order to be successful in the sport because the faster the ball is thrown at the goal, the less time the defenders and the goalkeeper have to save the shot. Others studies of elite female handball players show a mean throwing velocity of 17.1 - 22.2 m*s⁻¹ (Granados, Izquierdo, Ibañez, Bonnabau and Gorostiaga, 2007; Hoff and Almasbakk, 1995; Joris, Van Muyen, Van Ingen Schenau and Kemper, 1985; Saeterbakken, Van den Tillaar and Seiler, 2010; Van den Tillaar, 2004; Van Muijen, Joris, Kemper and Van Ingen Schenau, 1991; Zapartidis, Gouvali, Bayios and Boudolos, 2007). The velocities reached by our female handball players are in line with the aforementioned studies. If we compare 7 m velocities reported by Granados et al, (2007), in female Spanish handball players, we notice that their players had a mean throwing velocity of 19.5 m*s⁻¹. Our values are similar in throwing velocities with the goalkeeper (20.24 m*s⁻¹), and without the goalkeeper (20.58 m*s⁻¹). Nevertheless, the interpretation of these comparisons should be made with care because there are few studies published and the methodologies (radar gun, photogrametry, electronic timing gates) and sample levels are also different.

The truth is that, *a priori*, it could be expected that first line players (back and center) reached higher velocities than the other players because it is a very common throw for this specific position. This issue is confirmed in our study, but only at 9 m with a three step run with a goalkeeper throw. We found statistical differences between centers and wings.

Conclusions

These data indicate that position-specific ball speed depends on the main throw that is performed most often during training and matches.

carmen.manchado@ua.es

TIME-MOTION ANALYSIS AND PHYSIOLOGICAL DEMANDS IN INTERNATIONAL WOMEN'S TEAM HANDBALL

¹Carmen MANCHADO, ²Petra PLATEN

¹University of Alicante, Alicante, Spain; ²Ruhr-University Bochum, Bochum, Germany

Summary

We analyzed the horizontal movement pattern, including the sprint acceleration profiles, of individual female handball players of the Norwegian National Team and a German First League Team and the corresponding heart rates during a match. The results indicate that a high VO_{2max} appears to be important in top-level international women's handball. Sprint and endurance training should be conducted according to the specific demands of the player's position.

Keywords: Women's handball, heart rate, aerobic capacity, run velocity, acceleration

Introduction

In women's handball, data on movement patterns in combination with physiological demands are nearly nonexistent in the literature (Lidor et al. 2011, Manchado et al., 2011). In general, for sports science and professional disciplines, it is interesting and useful to investigate the movements imposed on players in sports games. Data on the distances covered by players, the velocities of their movements and their position in two-dimensional space during a game provide an important basis for the appropriate planning and distribution of load in training sessions, thus indirectly affecting the effectiveness of training (Erculj et al. 2008). In the past few years, a computer-vision system ("Sagit") using bird's eye video positioning has been developed and validated for the exact analysis of large-scale players' movements in sports such as handball (Pers et al. 2002). To date, this system has never been used for motion analysis of female handball players.

For about 20 years, highly developed aerobic performance, determined as maximal oxygen uptake (VO_{2max}), has been considered to be a fundamental basis for team handball on the international level (Platen 1989). This statement has been summarized for team sports in general in a recent review (Stone et al. 2009). It is astonishing that the handball-specific physiological demands have not been investigated systematically. Individual heart rate (HR) is a relatively easy-to-use parameter, especially since the development of the "Polar® Team System," which allows the storage of heart rate data in a transmitter that can be worn during competition without risk of injury. Continuous measurement of heart rates allows analysis of individual physiological demands during intermittent exercise, including team sports (McInnes et al. 1995, Achten et al. 2003). Only one study has investigated heart rates in female top-level handball players during competition so far (Manchado et al. 2007). This study reported a mean heart rate of 86 % of maximum heart rate with a broad variation of 75 % to 92 % between players. However, as no time-motion analysis was carried out during that study, interactions between movement patterns and physiological demands could not be determined. Therefore, the aim of this investigation was to exactly analyze large-scale movement patterns of top-level female handball players during a match in combination with the analysis of heart rate profiles as an indicator of individual physiological demands, and to deduce the influence of maximal oxygen uptake on these parameters.

Methods

25 handball players (25.2 ± 2.8 years, 67.8 ± 4.8 kg, 175.2 ± 6.3 cm) with different positions (3 goalkeepers, 9 backs, 8 wings and 5 pivot players) from a German First League team (n=11) and the Norwegian National Team (n=14) agreed to participate. VO_{2max} and maximum heart rate (HR_{max}) were determined during an incremental maximum intensity test on a treadmill. We investigated the Norwegian National Team during one match of an international tournament, and the German First League team during a First League match. For the time-motion analysis of player's movements, we used the Sagit computer-vision system. In short, video analysis included video calibration, automatic tracking and manual corrections (using the videos from the side of the playing field for controlling players' movements), manual annotation (optional), export of trajectory data and annotations to the file or export of graphical diagrams of trajectories, velocity and acceleration (Pers et al. 2002). Horizontal movements in the game were identified and assigned to five arbitrary velocity categories: stand ($0 \text{ m}\cdot\text{s}^{-1}$), walk ($0 - 1.3 \text{ m}\cdot\text{s}^{-1}$), slow run ($1.4 - 3.0 \text{ m}\cdot\text{s}^{-1}$), fast run ($3.1 - 5.2 \text{ m}\cdot\text{s}^{-1}$) and sprint ($>5.2 \text{ m}\cdot\text{s}^{-1}$). In addition to velocity, we also analyzed horizontal sprint accelerations of the players. The values for the acceleration categories were: A1 $< -4.5 \text{ m}\cdot\text{s}^{-2}$; A2 $\geq -4.5 < -3 \text{ m}\cdot\text{s}^{-2}$; A3 $\geq -3 < -1.5 \text{ m}\cdot\text{s}^{-2}$; A4 $\geq -1.5 < 0 \text{ m}\cdot\text{s}^{-2}$; A5 $\geq 0 < 1.5 \text{ m}\cdot\text{s}^{-2}$; A6 $\geq 1.5 < 3 \text{ m}\cdot\text{s}^{-2}$; A7 $\geq 3 < 4.5 \text{ m}\cdot\text{s}^{-2}$; A8 $\geq 4.5 \text{ m}\cdot\text{s}^{-2}$. One acceleration was counted whenever the player changed from one acceleration category to another. The summarized HR measure used was the mean heart rate and its individual equivalent as percentage of HR_{max} ($\%HR_{max}$). Individual demands were categorized into five intensity zones based on $\%HR_{max}$: zone I: $< 70 \%$; zone II: $70 - 85 \%$; zone III: $85 - 90 \%$; zone IV: $90 - 95 \%$, and zone V: $> 95 \%$ of HR_{max} (Helgerud et al. 2001).

Results

Players of the Norwegian National Team had a significantly higher aerobic performance (VO_{2max}) compared to the players of the German First League team (mean of both teams: $53.1 \pm 4.8 \text{ mL}\cdot\text{kg}^{-1}\cdot\text{min}^{-1}$; Norwegian team: $55.5 \pm 3.9 \text{ mL}\cdot\text{kg}^{-1}\cdot\text{min}^{-1}$; German team: $50.2 \pm 4.3 \text{ mL}\cdot\text{kg}^{-1}\cdot\text{min}^{-1}$; $p < 0.01$). Mean HR_{max} of all players was $194.8 \pm 1.0 \text{ min}^{-1}$. Values did not differ between both teams. There were no position specific differences concerning VO_{2max} and HR_{max} . $\%HR_{max}$ during the match was $78.4 \pm 5.9 \%$ for the goalkeepers and $86.5 \pm 4.5 \%$ for the field players. We did not find any differences between the two teams, between the two halves of the matches or between field players with different positions.

No differences concerning the time spent in the different heart rate zones were found between the two teams in any of the heart rate zones (table 1). No position-specific differences between the field players could be detected. Among the field players, time spent in heart rate zones higher than 85% of HR_{max} (Zones III, IV, and V) accumulated to more than 65% with about 9% spent in the highest intensity zone.

Table 1: Percentage of total time spent in the different heart rate zones of both teams for the whole match; values are means \pm standard deviation; Zone I: $<70\%$, zone II: $<85\%$, zone III: $<90\%$, zone IV: $<95\%$, zone V: $\geq 95\%$ HR_{max}

Both teams		
Field players (n=22)	Field players (n=22)	Goalkeepers (n=3)
	%	%
ZoneI	5.5 \pm 7.5	15.0 \pm 12.7
ZoneII	28.9 \pm 15.9	61.5 \pm 14.8
ZoneIII	24.1 \pm 11.6	20.5 \pm 24.7
ZoneIV	32.4 \pm 16.4	2.5 \pm 3.5
ZoneV	9.2 \pm 10.4	0.0 \pm 0.0

No significant differences could be detected between mean run distances, mean run velocities during the match, absolute values of run distances and the percentage of run distances spent in each velocity category of the field players between the two teams, between the first and second halves of the match, or between the different positions of the field players. Mean run distance of the field players was 2882 ± 1506 m, and 1377 ± 293 m for the goalkeepers. Sum of run distances was 5251 ± 242 m for all field players in one position, and reached 2066 ± 513 m for the goalkeeper position during one match. Mean run velocity of the field players was relatively slow with $70 \text{ m}\cdot\text{min}^{-1}$ ($4.2 \text{ km}\cdot\text{hr}^{-1}$). The field players covered 961 ± 539 m ($30.8 \pm 5.9 \%$) walking, 761 ± 420 m ($29.1 \pm 3.8 \%$) slow running, 752 ± 484 m ($29.7 \pm 3.9 \%$) fast running, and 272 ± 224 m ($10.5 \pm 4.1 \%$) sprinting. The goalkeepers covered 950 ± 290 m ($68.5 \pm 10.2 \%$) walking, 358 ± 100 m ($26.6 \pm 8.7 \%$) slow running, 67 ± 37 m ($4.7 \pm 2.3 \%$) fast running, and 3 ± 2 m ($0.2 \pm 0.2 \%$) sprinting.

We found a significant positive correlation between aerobic performance ($\text{VO}_{2\text{max}}$) and mean run velocity during the match in the group of the field players ($r=0.48$, $p<0.05$) (figure 1).

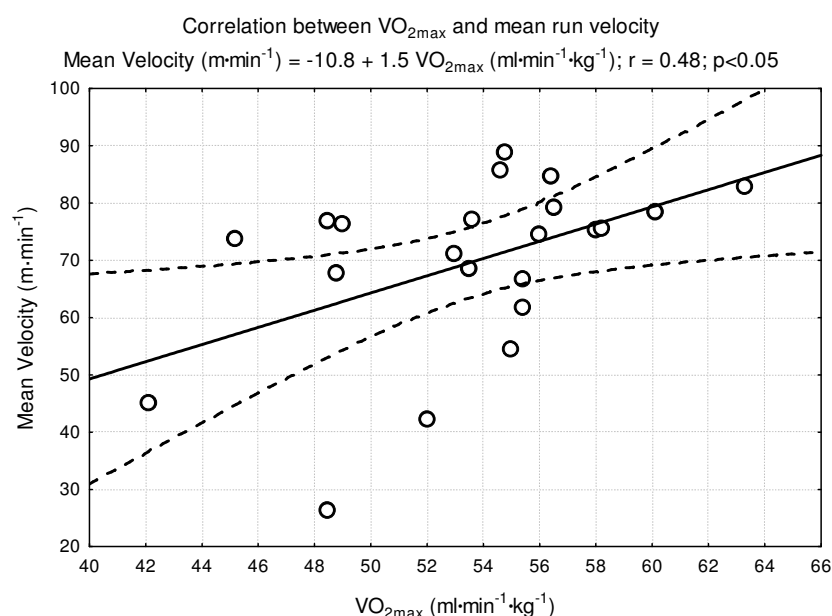

Figure 1: Correlation between maximal oxygen uptake ($\text{VO}_{2\text{max}}$) and mean run velocity during the match; only data of the field players are included.

Furthermore, $\text{VO}_{2\text{max}}$ was negatively correlated with the percentage of the total distance covered walking ($r = -0.63$, $p < 0.05$), while the percent values of the total distance covered for fast running and sprinting were both positively correlated with $\text{VO}_{2\text{max}}$ (percent fast running (%): $r=0.50$, $p < 0.05$, percent sprinting (%): $r=0.62$, $p < 0.05$).

The division of all field players into two equal-size subgroups of either lower ($< 54.0 \text{ mL}\cdot\text{kg}^{-1}\cdot\text{min}^{-1}$) or higher ($> 54.0 \text{ mL}\cdot\text{kg}^{-1}\cdot\text{min}^{-1}$) $\text{VO}_{2\text{max}}$ revealed a clear trend for a higher percentage of total distance spent sprinting in the players with a higher $\text{VO}_{2\text{max}}$ ($12.1 \pm 4.8 \%$ vs. $8.9 \pm 2.4 \%$, $p=0.07$), while percentage of total distance spent walking tended to be lower in this subgroup ($28.6 \pm 4.4 \%$ vs. $32.9 \pm 6.5 \%$, $p = 0.08$). The two subgroups did not differ in their distances in the run categories “slow running” and “fast running”, in their mean $\% \text{HR}_{\text{max}}$, and in the percentage of time spent in the different heart rate zones.

The total number of accelerations per minute was quite high with an amount of nearly 200 as mean number of both teams. The Norwegian National Team had a significantly lower number of total accelerations as well as number of accelerations in most of the different acceleration

categories as compared to the German First League team. There was no team effect on the number of accelerations in the different playing positions. There was, however, a clear position effect on the number of accelerations with the wing players showing the highest numbers of all positions, and the goalkeepers with clear trends towards a lower number in the high-acceleration categories A1-A3 and A6-A8.

Mean duration in each acceleration category was significantly higher in the Norwegian team in nearly all categories as compared to the German First League team. There was no team effect on the duration in each acceleration category in the different groups of playing positions. The wing players of both teams had significantly lower duration values in the middle acceleration categories A3, A5 and A6 as compared to the back and pivot players, and the goalkeepers' values were similar to the duration values of the field players. Mean distance covered in each acceleration category was higher for the Norwegian National Team as compared to the German First League team in all but the fastest categories (A1 and A8), while there was no position effect on the distance in any of the eight acceleration categories beside the fact that the goalkeepers had lower distances in all eight categories.

We found significant negative correlations between individual VO_{2max} values and the number of accelerations per minute in nearly all acceleration categories, including the total number of accelerations per minute. Furthermore, we found significant positive correlations between VO_{2max} and the duration of and distance in nearly all acceleration categories, besides the highest and lowest categories (A1 and A8). Duration of the highest acceleration category A8 was negatively correlated with VO_{2max} .

Discussion

The individual run distances of the female players during the matches varied broadly between single players. This is at least partly due to remarkable differences the individual playing time. The longer a player is on the field, the more she runs. Mean run distance of the players was similar to the distance covered by male top-level players during the World Championship in 2007 (2702 ± 1497 m for the female players and 2939 ± 1404 m for the male players) (Luig et al. 2008). The men's World Championship matches were analyzed with the same motion-analysis technique (Sagit system) as in this investigation. Other studies also using the Sagit system reported a mean total distance averaging 1777 ± 264 m per game in adolescent male handball players (Chelly et al. 2011), while male adult professional players covered 4464 – 5088 m (Pers et al. 2001), and male national players 4700 – 5600 m (Sibila et al. 2004). Differences between studies are probably mainly due to differences in playing time of one single player. As no data corrected for playing time are available from these studies, no direct comparisons can be made. With an average of 5251 ± 242 m for all field players with the same position, however, the female top players of our study fit well with the run distances of elite male handball players.

The most important finding of the present study is that the running performance of elite female handball players during a match varied in close association with differences in individual aerobic physical capacity. The field players with a higher aerobic performance not only ran with a higher mean velocity during the match, but also sprinted more. Because of their higher endurance capacity, individual physiological reactions (e.g. heart rates) remained in the same range as compared to those of the players with a lower aerobic performance (about 86 % of HR_{max}).

To our knowledge, acceleration profiles during matches have never been analyzed in handball or any other team sports so far. Dividing horizontal movements into eight different acceleration categories revealed a high mean number of distinct accelerations per minute for the players of

the two teams. With about 200 separate accelerations per minute, nearly three accelerations occurred per second. This finding suggests that top-level women's team handball is a game in which changes from one type of action to another are very frequent, and hence agility and speed are extraordinary important.

In our study we could demonstrate for the first time that acceleration profiles of horizontal movements in female top level handball players depend on aerobic performance. The fitter the players are, the fewer number of acceleration actions they have, but the longer they perform in all but the fastest of the different acceleration categories. This means that the fitter players are characterized by "calmer" movements and longer-lasting constant accelerations as compared to the less fit players. Whether these acceleration characteristics are associated with better handball-specific performance has to be analyzed in further studies. We could also demonstrate that the wing players differed significantly from all other playing positions in their acceleration profile: their higher number of accelerations per minute and their lower duration in each category is also an indicator for less "calm" movement behavior. Furthermore, players in this position were characterized by a higher number of single sprints per minute, a longer duration of each sprint, and a longer distance covered during each sprint. Again, this finding has to be confirmed in further studies.

Conclusion

Our results clearly show the importance of a high aerobic performance in women's team handball. Furthermore, wing players are characterized by remarkable differences in their acceleration and sprinting profiles as compared to other field players. This would mean that training programs should address 1) a superior level of aerobic performance and 2) the development of position-specific movement characteristics. Intermittent high-intensity endurance development must be carefully considered.

carmen_manchado@hotmail.com

THE RELATIVE AGE EFFECT IN BODY SIZE AND SUCCESS OF WORLD-CLASS HANDBALL PLAYERS

Luís Miguel MASSUÇA

Faculty of Physical Education and Sport, Lusófona University, Lisbon, Portugal
ICPOL, Higher Institute of Police Sciences and Internal Security, Lisbon, Portugal

Summary

To investigate the chronological age effect, of world-class handball players (WCHB), in body size and in success during handball (HB) competition, a sample of 939 WCHB was studied. The chronological age, height and weight, body mass index and optimal weight were studied. Age differences can result in significant variance in body size and success. Also height and weight seems relevant to be successful in world-class HB.

Keywords: Age, Body size, Handball, Top-Elite, Success.

Introduction

The association between morphology and performance has been considered in many contexts, commonly in youth sport participation. In fact, the study of body size remains a very active area of research in sports sciences and particularly in the throwing events like handball (HB).

According to Matkovic, Durakovic and Matkovic (2003), the morphologic characteristics of athletes can determine the success that athletes will achieve in a few particular sports. Anthropometric profile of elite HB players is first based in height and weight (Blanco, 2004). It seems that: (1) height determines the scope of use of vertical space (Ávila, 1996) and (2) weight is correlated with an athlete's speed, endurance and power (Ávila 1996; Cavas, Daglioglu, Hazar, Gurler & Yurdakoc, 2004).

Nevertheless, to fulfil equal opportunities for successful participation, HB athletes are grouped by chronological age (age-groups; e.g., U19, U21). However, differences between the youngest and the oldest ones (in the same age-group) may result due to significant differences in body size (Sharp, 1995).

Literature also reports that significant developmental advantages (i.e. height, weight and strength) have a relevant impact on perceived potential, performance (see Barnsley, Thompson & Legault, 1992; Rummenich & Rogol, 1995) and predicted success in sports (Helsen, Winckel & Williams, 2005). With this in mind, this study aims to investigate if chronological age differences, in world-class HB, can result in significant anthropometric and success differences.

Methods

A sample of 939 world-class handball players (WCHB) was studied: (1) Youth (U19) - 256 athletes from 16 youth HB national teams (2nd Men's Youth World Championship 2007, held in Bahrain), i.e., Algeria, Argentina, Australia, Bahrain, Brazil, Croatia, Denmark, Egypt, Iran, Korea, Morocco, Poland, Qatar, Spain, Sweden and Tunisia; (2) Junior (U21) - 289 athletes from 18 junior HB national teams (16th Men's Junior World Championship 2007, held in FYRO Macedonia), i.e., Angola, Argentina, Brazil, Bulgaria, Croatia, Denmark, Egypt, France, Macedonia, Germany, Korea, Kuwait, Portugal, Russia, Slovakia, Slovenia, Spain and Tunisia; and (3) Senior - 394 from 24 senior national teams (20th Men's World Championship 2007, held in Germany), i.e., Angola, Argentina, Australia, Brazil, Croatia, Czech Republic, Denmark, Egypt, France, Germany, Greenland, Hungary, Iceland, Korea,

Kuwait, Morocco, Norway, Poland, Qatar, Russia, Slovenia, Spain, Tunisia and Ukraine (see Table-1).

Age, height and weight were collected from the International Handball Federation official site (www.ihf.info) and, the body mass index ($BMI = \text{weight}[\text{kg}] / \text{height}[\text{m}]^2$) and optimal weight ($Op_WT = (\text{height}[\text{cm}] - 100) / \text{weight}[\text{kg}]$, see Cercel, 1980) were calculated.

Statistical analysis involved: (1) variables description, though mean and standard deviation (SD); (2) analysis of variance (ANOVA) one-way and Tukey HSD Post-Hoc Test for multiple comparisons to assess differences between age-groups (youth, junior and senior); (3) *t*-test for equality of means (Independent Sample Test) to assess differences between first four national HB teams and last four standing national HB teams per age-group; and (4) analysis of covariance (ANCOVA) with chronological age as covariate to evaluate the influence of this variable in success. For all analyses, 5% was adopted as the significance level. The data were processed with the program PASW 18.0.

Table 1. National teams, number of players and World Championship Classification.

National Team	Youth ⁽ⁱ⁾		Junior ⁽ⁱⁱ⁾		Senior ⁽ⁱⁱⁱ⁾		Total N
	Final Standings	N	Final Standings	N	Final Standings	N	
Algeria	14	16	-	-	-	-	16
Angola	-	-	19	16	21	16	32
Argentina	4	16	13	16	16	16	48
Australia	16	16	-	-	24	16	32
Bahrain	8	16	-	-	-	-	16
Brazil	9	16	16	16	19	17	49
Bulgaria	-	-	18	14	-	-	14
Chile	-	-	20	^(iv)	-	-	0
Croatia	2	16	4	16	5	18	50
Czech Republic	-	-	-	-	12	16	16
Denmark	1	16	3	16	3	17	49
Egypt	5	16	6	16	17	17	49
France	-	-	7	18	4	16	34
FYRO Macedonia	-	-	10	16	-	-	16
Germany	-	-	2	17	1	16	33
Greenland	-	-	-	-	22	15	15
Hungary	-	-	-	-	9	17	17
Iceland	-	-	-	-	8	17	17
Iran	12	16	-	-	-	-	16
Korea	11	16	11	16	15	16	48
Kuwait	-	-	12	16	18	16	32
Morocco	15	16	-	-	20	15	31
Norway	-	-	-	-	13	18	18
Poland	6	16	-	-	2	16	32
Portugal	-	-	15	16	-	-	16
Qatar	10	16	-	-	23	16	32
Russia	-	-	9	16	6	17	33
Slovakia	-	-	14	16	-	-	16
Slovenia	-	-	8	16	10	16	32
Spain	7	16	5	16	7	16	48
Sweden	3	16	1	^(iv)	-	-	16
Tunisia	13	16	17	16	11	18	50
Ukraine	-	-	-	-	14	16	16
Total	16 Teams	256	20 Teams	289	24 Teams	394	939

ⁱ IInd Men's Youth World Championship 2007 (in Bahrain);

ⁱⁱ XVIth Men's Junior World Championship 2007 (in FYRO Macedonia);

ⁱⁱⁱ XXth Men's World Championship 2007 (in Germany);

^{iv} Data not available in International Handball Federation official site.

Results

Significant differences were found between age-groups in height ($F_{2,936}=12.435$), weight ($F_{2,936}=52.967$), BMI ($F_{2,936}=38.666$) and optimal weight ($F_{2,936}=41.908$, all $p<0.001$). Moreover, multiple comparisons showed significant differences between: (1) youth and senior age-groups ($p<0.001$); (2) junior and senior age-groups (height, $p<0.01$; weight, BMI and optimal weight, $p<0.001$); and (3) youth and junior age-groups (weight, $p<0.01$; optimal weight, $p<0.05$). These findings are presented in Figure-1.

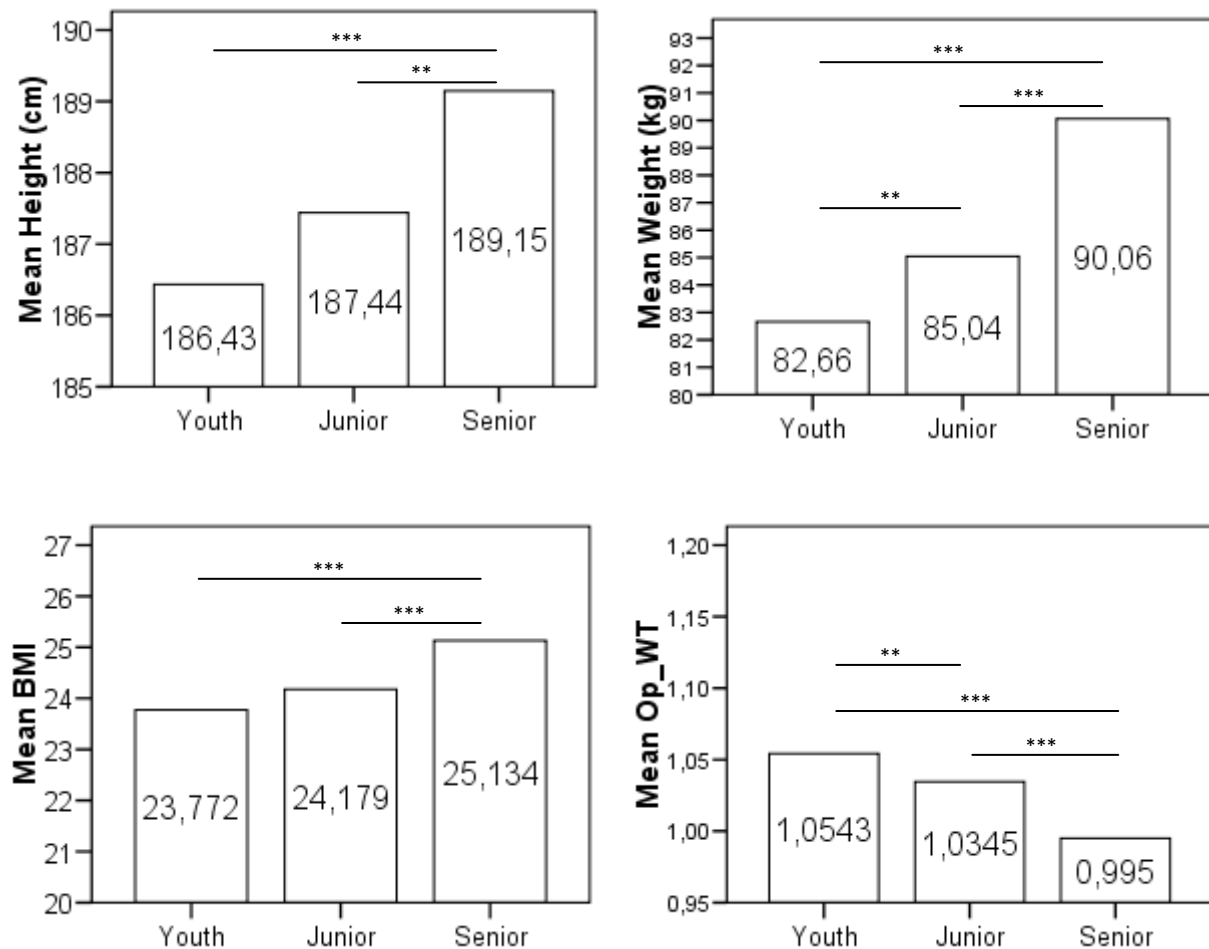

The mean difference is significant at the: *, $p<0.05$; **, $p<0.01$; ***, $p<0.001$.

Figure 1. Differences between age-groups of IHF international tournaments (youth, $n=256$; junior, $n=289$; senior, $n=394$) on body size variables (height, weight, BMI and optimal weight).

The results also highlighted that WCHB non-successful group (N-S) were (in mean) youngest (youth, $t(118.010)=-4.103$, $p<0.001$; junior, $t(99.270)=-4.372$, $p<0.001$; senior, $t(108.112)=-3.160$, $p=0.002$). These findings are presented in Table-2.

Table 2. Differences in age between success groups and according to age-groups.

		N	Mean	SD	SE	95% CI		Min	Max	Sig.
						Lower	Upper			
Youth	N-S	64	17.84	0.89	0.11	17.62	18.07	16	19	***
	S	64	18.42	0.69	0.09	18.25	18.59	17	19	
Junior	N-S	62	19.50	1.35	0.17	19.16	19.84	16	21	***
	S	49	20.39	0.76	0.11	20.17	20.61	18	21	
Senior	N-S	63	24.89	5.45	0.69	23.52	26.26	17	35	**
	S	65	27.49	3.67	0.45	26.58	28.40	21	36	

N-S, Last four teams in final standing; S - First four teams in final standing.

The mean difference is significant at the: **, $p < 0.01$; ***, $p < 0.001$.

WCHB players from non-successful groups were (in mean) shorter (youth, $t(126) = -3.054$, $p = 0.003$; junior, $t(109) = -4.396$, $p < 0.001$; senior, $t(126) = -6.130$, $p < 0.001$) and lighter (youth, $t(126) = -3.343$, $p = 0.001$; junior, $t(108.984) = -5.171$, $p < 0.001$; senior, $t(126) = -4.488$, $p < 0.001$). Only the junior sample showed significant differences in the BMI (youth, $t(126) = -1.244$, $p = 0.216$; junior, $t(109) = -2.551$, $p = .012$; senior, $t(101.041) = -0.586$, $p = 0.559$) and optimal weight (youth, $t(126) = 1.306$, $p = 0.194$; junior, $t(109) = 2.526$, $p = 0.013$; senior, $t(101.074) = 0.496$, $p = 0.621$). Nevertheless, the results of ANCOVA (with chronological age has covariate) erased the observed differences between success groups in BMI and optimal weight were not significant (BMI, $p = 0.325$; Op_WT, $p = 0.400$). These findings are presented in Table-3.

Discussion

According to Silva, Figueiredo, Sobral and Malina (2004), studies of the anthropometric characteristics of athletes has a long tradition in sport sciences and, usually height and weight are the two body size dimensions commonly used to monitor athletes.

In this study, the significant differences were observed between age-groups in all body size variables (Figure-1). However, note that the data probably reflects the body size demand of handball for individual age-group.

Also the interpretation of the BMI in athletes needs care, i.e., elevated BMI is not necessarily indicative of fatness.

In the study of athletic success were observed that success HB tends to born early in the selection years (Table-2). These differences may be related to differences in: (1) experience as a function of age (Helsen, Hodges, Van Winckel & Starkes, 2000; Ward, Hodges, Williams & Starkes, 2004; Ward & Williams, 2003); and; (2) body size (height and weight: youth, $p < 0.01$; junior and senior, $p < 0.001$; BMI and optimal weight: junior, $p < 0.05$).

According to these global results it seems that booth basic measures (i.e., height and weight) are very important to achieve a high level of performance in HB. In fact, Vand den Tillar and Ettema (2004) showed that body size had a strong positive effect on the throwing performance and isometric strength ($r = 0.43$, $p = 0.056$). Moreover, weight appears to be essential, especially in 1vs1 situations (Moreno, 1997) and for this reason elite HB players are very heavy (Bayer, 1987). However, in contrast to height, body weight can be influenced by regular training (i.e., decrease in fatness and occasionally with an increase in fat-free mass).

Table 3. Differences between success groups in body size variables (by age-groups) and age effect.

			t test								ANCOVA (Age)					
			N	Mean	SD	SE	95% CI		Max	Min	Sig	Mean	SE	95% CI		Sig
							Lower	Upper						Lower	Upper	
Youth	Height (cm)	N	6	185.5	5.93	0.7	184.03	187.00	170	201		185.55 ^a	0.8	183.8	187.2	
		-S	4	2		4						**	7	4	7	**
		S	6	189.1	7.36	0.9	187.29	190.96	172	209		189.09 ^a	0.8	187.3	190.8	**
	Weight (kg)	N	6	81.38	8.15	1.0	79.34	83.41	63	103		81.84 ^a	1.1	79.60	84.07	
		-S	4			2					**	3				*
		S	6	86.58	9.41	1.1	84.23	88.93	70	111		86.12 ^a	1.1	83.88	88.35	*
	BMI	N	6	23.68	2.51	0.3	23.05	24.31	18.81	31.83		23.81 ^a	0.3	23.21	24.41	
		-S	4			1					NS	0				NS
		S	6	24.20	2.19	0.2	23.65	24.74	20.62	31.07		24.07 ^a	0.3	23.47	24.67	NS
	Op_W T	N	6	1.06	0.11	0.0	1.03	1.09	0.76	1.32		1.06 ^a	0.0	1.03	1.08	
		-S	4			1					NS	1				NS
		S	6	1.04	0.09	0.0	1.01	1.06	0.80	1.21		1.04 ^a	0.0	1.02	1.07	NS
Junior	Height (cm)	N	6	185.7	6.15	0.7	184.2	187.3	171	202		185.49 ^b	0.8	183.8	187.1	
		-S	2	9		8	3	5			**	2	6	3	**	
		S	4	191.0	6.48	0.9	189.22	192.94	174	203	*	191.46 ^b	0.9	189.6	193.3	*
	Weight (kg)	N	6	81.89	9.29	1.1	79.53	84.25	63	108		82.52 ^b	1.0	80.37	84.68	
		-S	2			8					**	9				**
		S	4	90.00	7.24	1.0	87.92	92.08	74	104	*	89.20 ^b	1.2	86.75	91.64	*
	BMI	N	6	23.70	2.23	0.2	23.14	24.27	17.7	29.5		23.96 ^b	0.2	23.49	24.42	
		-S	2			8			2	4	*	4				NS
		S	4	24.64	1.46	0.2	24.22	25.06	21.04	27.99		24.32 ^b	0.2	23.79	24.85	NS
	Op_W T	N	6	1.06	0.10	0.0	1.03	1.08	0.84	1.41		1.04 ^b	0.0	1.02	1.06	
		-S	2			1					*	1				NS
		S	4	1.01	0.06	0.0	1.00	1.03	0.89	1.19		1.03 ^b	0.0	1.01	1.05	NS
Senior	Height (cm)	N	6	184.3	6.65	0.8	182.63	185.98	170	198		184.27 ^c	0.8	182.5	185.9	
		-S	3	0		4					**	6	6	8	**	
		S	6	191.5	6.73	0.8	189.89	193.22	170	205	*	191.59 ^c	0.8	189.9	193.2	*
	Weight (kg)	N	6	84.94	10.5	1.3	82.28	87.59	61	120		85.32 ^c	1.2	82.95	87.70	
		-S	3		6	3					**	0				**
		S	6	92.38	8.10	1.0	90.38	94.39	72	106	*	92.01 ^c	1.1	89.68	94.34	*
	BMI	N	6	24.96	2.23	0.2	24.39	25.52	20.38	31.24		25.08 ^c	0.2	24.62	25.53	
		-S	3			8					NS	3				NS
		S	6	25.15	1.34	0.1	24.81	25.48	21.61	28.19		25.03 ^c	0.2	24.58	25.47	NS
	Op_W T	N	6	1.00	0.09	0.0	0.98	1.02	0.80	1.20		1.00 ^c	0.0	0.98	1.01	
		-S	3			1					NS	1				NS
		S	6	0.99	0.05	0.0	0.98	1.01	0.89	1.15		1.00 ^c	0.0	0.98	1.02	NS

Success Groups: N-S, Non-successful (last four teams in final standing); S, Successful (first four teams in final standing). Covariates appearing in the model are evaluated at the following values: ^a, Age=18.13; ^b, Age=19.89; ^c, Age=26.21. The mean difference is significant at the: NT, not significant; *, $p < 0.05$; **, $p < 0.01$; ***, $p < 0.001$.

It can explain the chronological age effect on BMI and optimal weight in junior WCHB. Nevertheless, it needs to be investigated.

Finally, we would like to say that body size characteristics are important, but they are not the only determinants of successful performance (even when associated with growth and maturation of the athlete). They are a small part of a complex multidisciplinary set of characteristics related to the demands of HB.

Conclusion

Age differences can result in significant variance in body size and success. It is also increasingly apparent that in all age-groups, the WCHB success groups often showed the same differences (in body size) when compared to non-success WCHB group (i.e., height and weight seems relevant to be successful in world-class HB).

However, further research is needed to explore WCHB from a multidisciplinary approach.

luis.massuca@gmail.com

ACTIVITY MATCH PROFILE AND PHYSIOLOGICAL DEMANDS IN FEMALE ELITE TEAM HANDBALL

Lars Bojsen MICHALSIK¹, Klavs MADSEN¹, Per AAGAARD²

¹Aarhus University, Aarhus, Denmark ²University of Southern Denmark, Odense, Denmark

SUMMARY

The present study revealed that modern female elite Team Handball (TH) is a physically demanding intermittent team sport, where the players show substantial aerobic energy expenditure throughout the entire match and demonstrate only short periods of dominant anaerobic energy production. There were indications that temporary fatigue and a subsequent decline in performance may occur. Positional differences in physical demands were observed.

Keywords: Locomotion match analysis, high-intensity running, physiological measurements, physical testing, positional differences

INTRODUCTION

TH is an old ballgame. Most researchers believe that the game originated in Denmark, where the first historical evidence dates from around 1897. Unlike many other old sports disciplines women soon followed men by beginning to play TH as early as 1905. The requirements for elite players have changed as the game of TH has developed over the years. The amount of training and the number of matches have increased considerably and the recently introduced rule on quick throw-off and the tightening-up of the rule concerning passive playing have led to an increased number of attacks, intensity and TDC for female elite players (Ronglan et al., 2006). This has contributed to increase the dynamics and physical demands imposed on the players. With this development in mind, there is a need to examine, plan and implement optimal physical training regimes in modern female TH. The design of the training for present-day elite players should be planned and executed based on a specific working demand analysis in order to meet the on-court playing demands (Michalsik, 2004).

Further, physiological measurements during match-play can be performed. The physical demands of elite TH players can e.g. be assessed by continuous heart rate (HR) recording and subsequent determination of the relative work load (RWL) to evaluate the aerobic loading during match-play. In addition, it seems relevant to investigate possible differences in the physical demands between various playing positions. Different physical requirements would suggest that the physical training should be performed more individually at the expense of the more traditional collective way, where similar types of training are conducted using identical intensity and frequency in all players. Furthermore, various physical performance tests can be performed. Based on a presumption that the players have adapted to the working demands of the game through many years of TH training, such test results can provide additional information about the working requirements (Michalsik & Bangsbo, 2002). Finally, it remains unknown whether the performance of female elite TH players is inhibited during match-play due to accumulation of fatigue. Knowledge regarding fatigue or impaired physical performance can be useful and may facilitate the designing of optimal physical training regimes in female elite TH. This aspect can be examined by analyzing the change in high-intensity activity throughout an entire match as recently done in male elite TH (Michalsik et al., 2011).

The aim of the present study, therefore, was to (i) determine the physical and physiological demands placed on female elite TH players and (ii) to identify positional differences in these parameters, and (iii) to examine whether fatigue occurs during elite TH match-play. To fully investigate these aspects of TH, it is important to include a large number of players from different teams representing all playing positions, since significant variations in activity pattern may be found from match to match, between different teams and between players within each position, respectively. The present study comprised locomotion match analysis, physiological measurements during match-play and physical testing in a large group of Danish female elite TH players. Since the activity patterns of goalkeepers obviously differ substantially from the field players', the physical demands placed on goalkeepers were not examined.

METHODS

Elite TH players from the Danish Premier female Handball League (DHL) including particularly two top ranked teams were recruited for the experiments and examined over a five-year period. All players were fully informed of all experimental procedures before giving their written informed consent to participate. The conditions of the study were approved by the local ethics committee. The physical characteristics of the players from the two top ranked teams (10 wing players (WP), 7 backcourt players (BP) and 7 circle runners (CR), $n=24$) were 25.9 ± 3.8 years, 174.2 ± 5.7 cm and 70.3 ± 7.4 kg with 6.9 ± 3.3 years of playing experience at senior elite level (group means \pm SD), respectively.

Observations during match-play - video recording

Competitive games were taped in such a manner that one camera captured one player close up without interruption throughout the entire time course of the match. A total of 180 recordings were obtained in 46 full-length tournament matches in DHL. For the recorded data to be included in the study, effective playing time for the whole match had to be 42 min or more (i.e. ~70 % of total effective playing time (TPT)) with an effective playing time in one half of the game of 18 min or more (i.e. ~60 % of TPT). A total of 83 recordings fulfilled these conditions and were analyzed according to established criteria. Field-players were divided into three categories in both offence and defence, WP, BP and CR, respectively. A total of 8 locomotive categories were registered. Total distance covered (TDC) during a match was calculated as the sum of the distances covered in each type of locomotion. The movement categories were standing still ($0 \text{ km}\cdot\text{h}^{-1}$), walking ($4 \text{ km}\cdot\text{h}^{-1}$), jogging ($7 \text{ km}\cdot\text{h}^{-1}$), running ($12 \text{ km}\cdot\text{h}^{-1}$), fast running ($15.5 \text{ km}\cdot\text{h}^{-1}$), sprinting ($22 \text{ km}\cdot\text{h}^{-1}$), sideways movement ($9 \text{ km}\cdot\text{h}^{-1}$) and backwards running ($\text{km}\cdot\text{h}^{-1}$). The selected speeds were the same for all players. All running speeds were specific for female elite TH players and lower than those used in male elite TH players (Michalsik et al., 2011). To ensure a high consistency and reproducibility, the repeated video analysis was conducted by the same observer, who was experienced with this type of analysis.

Physiological measurements during match-play

The physiological work load during tournament matches was registered by continuous HR monitoring in successive 5-s intervals. Blood sampling in connection with tournament matches was not allowed.

Physiological capacity analysis - laboratory treadmill testing

An incremental treadmill running test was performed, which consisted of a submaximal test followed by an exhaustive incremental maximal test (all-out test). Respiratory measurements were conducted using online analysis. HR was continuously recorded in 5-s intervals throughout the test using a HR monitor. The individual HR- VO_2 relationship obtained during the treadmill

test was used to estimate VO₂ during match-play based on the players HR during match-play. Subsequently, the relative work load (RWL) during match-play expressed as % of VO₂-max could be determined.

Field testing - Yo-Yo intermittent recovery test

The ability to work intensely and to recover quickly after intense work bouts were assessed on the TH court using the Yo-Yo intermittent recovery test, level 1 (YIR1-test), as described Bangsbo et al. (2008). A pre-study familiarization test round was performed in all players. All results are presented as group mean values ± standard deviations (SD). The level of significance was set at p<0.05 using a two-tailed test design.

RESULTS

Activity match profile

Table 1. Offensive and defensive actions per match for all players combined (n=83) for the eight categories in the locomotion analysis. Results are mean ± SD.

Offensive and defensive actions in total for the entire match				
	Playing time per match (s)	% of total playing time per match	Distance covered (m)	% of distance covered
Standing still	329±118	10.8	0	0
Walking	1893±229	62.3	2103.6±334.1	52.6
Jogging	573±112	18.8	1114.2±218.7	27.8
Running	149±77	4.9	496.0±252.3	12.4
Fast running	22±16	0.7	92.6±67.0	2.3
Sprinting	2±2	0.1	9.8±11.2	0.2
Sideways movement	55±40	1.8	138.0±99.1	3.5
Backwards running	19±14	0.6	48.2±32.3	1.2
Total	3042±350	100	4002.4±551.4	100
Offensive actions in total for the entire match				
	Playing time per match (s)	% of total playing time per match	Distance covered (m)	% of distance covered
Standing still	146±92	9.9	0	0
Walking	903±243	61.2	1003.9±270.7	50.9
Jogging	312±73	21.1	606.7±141.2	30.8
Running	70±40	4.8	234.4±133.2	11.9
Fast running	10±9	0.7	40.9±38.5	2.1
Sprinting	1±1	0.1	3.7±6.1	0.2
Sideways movement	22±17	1.5	55.8±41.8	2.8
Backwards running	10±8	0.7	24.8±19.1	1.3
Total	1474±259	100	1970.2±322.6	100
Defensive actions in total for the entire match				
	Playing time per match (s)	% of total playing time per match	Distance covered (m)	% of distance covered
Standing still	184±79	11.7	0	0
Walking	989±189	63.1	1099.6±212.2	54.1
Jogging	261±65	16.6	507.3±127.4	24.9
Running	79±40	5.0	261.7±65.3	12.9
Fast running	12±8	0.8	51.7±37.6	2.5
Sprinting	1±1	0.1	6.1±8.7	0.3
Sideways movement	33±26	2.1	82.3±64.3	4.1
Backwards running	9±7	0.6	23.5±19.2	1.2
Total	1568±230	100	2032.2±362.2	100

Mean number of activity changes per match for all players combined (n=83) was 663.6±100.1 per player with an average of 16.4±9.7 high-intensity runs per match. With a mean TPT of 50.70±5.83 min, each player showed an activity change each 4.6 s. Mean playing time per match spent in the three locomotive categories were 37.22±4.95 min at low intensity (standing still, walking), 13.10±2.77 min at moderate intensity (jogging, running, sideways movement, backwards running) and 23±15 s at high intensity (fast running, sprinting). The average duration of fast running and sprinting for all players combined was 1.46 s per action and 0.84 s per action, respectively. Standing still and walking constituted 73.1±4.8 % of TPT per match. In contrast, the amount of HIR, which consisted of fast running and sprinting, constituted 0.8±0.5 % of the TPT per match corresponding to 2.6±1.8 % of TDC per match (Table 1). Mean TDC were 4002.4±551.4 m. Activity patterns differed between various playing positions. Both WP (4085.5±669.4 m, p<0.05) and CR (4066.9±544.7 m, p<0.05) covered a greater total distance per match than BP (3866.6±385.9 m). Players, who played full time (60 min's playing time, n=10, mostly WP), performed a greater TDC (4692.8±332.6 m, p<0.05) compared to non-full-time players (3907.8±506.2 m, n=73). WP performed more HIR (3.6±1.5 % of TDC, p<0.01) than both CR (2.3±1.5 %) and BP (1.3±0.9 %). HIR constituted 3.3±1.2 % of TDC among full-time players. Separated in offence and defence, marked positional differences were demonstrated. WP performed in both cases more HIR than CR and BP.

Physiological measurements during match-play

Mean HR during active playing on the court (n=46) was 170.5±7.2 beats·min⁻¹. RWL during match-play averaged 79.4±6.4 % of VO₂-max when all players were combined. However, considerable individual variations in RWL were observed, since players typically showed transient periods with a RWL corresponding to over 90 % of VO₂-max, while at other times they performed with a load below 60 % of VO₂-max. Positional differences were demonstrated, where CR played with a higher mean RWL (83.1±4.9 % of VO₂-max) than WP (78.4±5.9 % of VO₂-max, p<0.05) and BP (75.8±6.5 % of VO₂-max, p<0.01).

Physiological capacity

Selected results from the treadmill test are presented in Table 2. Expressed relative to body mass (ml O₂·min⁻¹·kg⁻¹) or as Fitness Index (ml O₂·min⁻¹·kg^{-0.73}), VO₂-max did not differ between playing positions. WP ran longer time at the all-out test (377.4±43.1 s, p<0.05) than both CR (335.2±57.2 s) and BP (331.4±40.4 s). Total running distance for all field players combined (n=18) in the YIR1-test averaged 1436±222 m. Positional differences were demonstrated as WP (1516±172 m) ran longer (p<0.05) than both CR (1360±118 m) and BP (1352±148 m).

Table 2. Body mass, absolute and relative maximal oxygen uptake as well as Fitness Index and total running time to exhaustion at the treadmill test for Danish female elite Team Handball players. Results are mean ± SD.

Playing positions	All players combined (n=24)	Wing players (n=10)	Circle runners (n=7)	Backcourt players (n=7)
Body mass (kg)	70.3±7.4	65.2 ±2.7*	76.5±8.1 ***	71.4±6.1
VO ₂ -max (l O ₂ ·min ⁻¹)	3.28±0.37	3.10±0.37*	3.53±0.33 ***	3.29±0.33
VO ₂ -max (ml O ₂ ·min ⁻¹ ·kg ⁻¹)	47.5±4.8	48.3±5.0	47.2±5.8	46.8±4.5
Fitness Index (ml O ₂ ·min ⁻¹ ·kg ^{-0.73})	147.3±15.3	146.7±16.8	149.9±18.6	146.0±13.8
Total running time (s)	345.7±52.5	377.4±43.1#	335.2±57.2	331.4±40.4

*Difference between wing players and circle runners * p<0.01, between wing players and backcourt players ** p<0.01, between circle runners and backcourt players *** p<0.01 and between wing players and circle runners & backcourt players # p<0.05.*

Differences between first and second half of the match

Both in offence, in defence and in offence and defence combined substantial differences were observed between the first and the second half for the three most important locomotive categories (running, fast running, sprinting) as well for the mean speed (Figure 1). For all players combined, the number of low-intensity activities increased ($p < 0.05$), whereas the number of high-intensity activities were reduced ($p < 0.05$) in the second half. Further, the amount of HIR was lower in the second half (44.9 ± 20.8 m) than in the first (57.5 ± 27.3 m, $p < 0.05$) corresponding to a decrease of 21.9 % with only 6 s less actual mean playing time in the second half. No difference was observed in TDC between the first (2009.7 ± 361.8 m) and the second half (1992.7 ± 382.2 m). For all players combined and for the specific playing positions, RWL during match-play was higher in the first than in the second half of the match.

DISCUSSION

In the present study, mean TDC was 4002 m with a mean TPT of 50.70 min. Due to the large number of analyzed matches (46 matches, 83 analyzed players from several different teams), the results from the present study likely provides a realistic picture of mean TDC in elite female TH players during match-play.

It is notable that HIR only constituted 0.8 % of TPT per match in present study. However, this does not mean that the ability to work at high intensity is of little importance in modern female elite TH and therefore not should be a priority in the physical training. Potentially, a large HIR capacity is crucial for playing actions such as fast breaks, explosive fakes, side cuttings, offensive breakthroughs and fast retreats, and thus may also play a decisive role for the outcome of a match. The mean duration of the separate sprint actions was calculated to be 0.84 s corresponding to a running distance of approximately 6 m per sprint action, which means that real sprinting on average take place with very short duration in female elite TH. Even though the mean sprint time also covers sprinting in other situations than fast break and that the duration of numerous small accelerations is considerable shorter than the mean sprint duration, the value of 0.84 s is markedly less compared to the time it takes to perform a fast break at maximum speed (about 4-5 s). This indicates that in female elite TH, a fast break is only rarely a maximal sprint all the way up the court. In TH it is essential to react quickly and perform powerful changes in direction, while moving quickly over short distances. Physical training exercises, therefore, primarily should target reaction speed and acceleration (i.e. rate of force development, RFD) rather than focus on maximum running speed.

The present findings of reduced amounts of HIR, decreased RWL and a reduced number of high-intensity activity changes in the second half indicate that at least temporary and maybe a more permanent form of locomotive fatigue and impaired physical performance may occur in some players. It may be argued that the decreased intensity in the second half was caused by the outcome of the match already being settled early in the second half. However, evidence of such a relationship was not found in the present study. The present analysis demonstrates that significant differences exist in the movement pattern of the various field playing positions. Running training in female elite TH should therefore be organised in a way that accounts for the specific playing positions, while also recognizing the players' individual level of physical capacity as well as their individual recovery profile.

The present data show that elite female TH impose relatively high demands on the player's aerobic energy production (aerobic power and capacity) as reflected by the mean RWL (~80 % of VO_2 -max). The relative high level of estimated VO_2 during match-play may be due to the

players running for a large proportion of the match with attention fixed on the ball or directly with the ball, which increases VO_2 (Reilly & Ball, 1984). The mean total running distance covered for all the field players combined in the YIR1-test (1436 m) was somewhat lower (~5-7 %) than measured in the Danish female National Team, who won Olympic Gold medals in 2000 (1505 m, n=16) and the European championship in 2002 (1538 m, n=18) (Michalsik, unpublished data). In team ballgames, a large variability in Yo-Yo test results frequently exists within a team. Nevertheless, a minimum standard may be set in a specific sport, suggesting that a basic level of fitness (to perform repeated intense exercise) is needed to perform at a high level. With more results this can also be done in the future in female elite TH.

CONCLUSIONS

To our best knowledge, this is the first study to examine the physical demands in female elite TH using a complete locomotion match analysis. The present findings provide evidence that modern female elite TH places high demands on the players' aerobic (cardio-vascular) system during match-play as evidenced by a RWL corresponding to ~80 % of VO_2 -max and that the amount of high-intensity running is limited (~1 % of total playing time per match). Playing intensity often changes from standing still and walking to maximal explosions in fast breaks, take-offs, side-cuttings, fakes and tackling situations as each player showed a mean number of 13 activity changes per min. Thus, modern female elite TH can be characterized as a truly intermittent game. In organized attack, female elite TH is played at a relatively uniform pace where players frequently are walking, but rarely stand still. At the same time, it is performed with intense tempo changes and changes in direction. Although only constitutes a very minor fraction of the total distance covered, the ability to rapidly change pace and accelerate in specific game actions throughout the entire match still have considerable significance for the outcome of a game.

The decrease in the total number of high-intensity activity changes, the amount of high-intensity running, mean speed and relative work load in the second half of the match collectively indicates that temporary fatigue and impaired performance appear to occur in players with more than 50 min playing time per match. Extensive positional differences were observed in the physical demands during match-play. These differences should be taken into account, when planning the training of elite TH players. Thus, individualized physical training should be given a high priority compared to the more traditional collective way. In view of the complex nature of the game and the need to master many types of movement categories including high-intensity running, it is necessary to develop players, who should possess a multitude of physical qualities, but where the optimizing of the single physical parameter should be abandoned in favor of the training of other physical characteristics. The present findings may be useful in the planning and implementation of training regimens to optimize the position-specific physical training in female elite TH.

LBMichalsik@health.sdu.dk

MATCH PERFORMANCE AND PHYSIOLOGICAL CAPACITY OF MALE ELITE TEAM HANDBALL PLAYERS

Lars Bojsen MICHALSIK¹, Per AAGAARD², Klavs MADSEN¹

¹Aarhus University, Aarhus, Denmark ² University of Southern Denmark, Odense, Denmark

SUMMARY

The present study demonstrated that modern male elite Team Handball (TH) comprises several types of movement categories, which during match-play place moderate-to-high demands on intermittent endurance running capacity and where the anaerobic energy turnover may be very high in short periods of time. Signs of temporary fatigue and impaired physical performance were observed. Notably, physical demands differed substantially between playing positions.

Keywords: Locomotion match analysis, physiological measurements, physical testing, temporary fatigue, positional differences

INTRODUCTION

Knowledge of the working demands in any type of sport is a precondition for the planning and execution of optimal training. Analysis of the physical demands in elite TH may be used to indicate the proportion of the total training that should consist of physical training, and to identify how different physical training elements should be weighted.

Further, measuring of the players' physical capacity by means of various physical tests may be used to assess the physical demands based on an assumption that the players have adapted to the working demands of the game through many years of elite TH training (Michalsik & Bangsbo, 2002). Furthermore, physiological measurements during match-play can e.g. be performed by continuous heart rate (HR) recording and subsequent determination of the relative work load (RWL) to evaluate the aerobic loading during match-play. In addition, it is relevant to examine to which extent difference exist in the physical demands imposed by various playing positions. In case of such differences, physical training should be organised in a more individualized manner, rather than providing a uniform type of training to all players on a team. Finally, it is also unclear to what extent elite TH players experience fatigue during a game. The degree to which fatigue occurs in elite TH can be assessed by analyzing the change in high-intensity activity throughout a competitive game. Findings regarding fatigue in TH may provide useful information for planning and implementing of physical training in elite TH players.

Since both the nature of the game of TH and the scientific methods of analysis have developed considerably in the last decades, there is a need for a thorough analysis of the physical demands of modern elite TH in order to establish the physical requirements placed on elite players of today. The aim of the present study, therefore, was to (i) determine the physical demands imposed on male elite TH players, (ii) to identify potential differences between various playing positions, and (iii) to examine whether fatigue occurs during an elite TH match. To examine these aspects of TH, it is necessary to include a large number of players from different teams representing all playing positions, since considerable variations in activity pattern may be found from match to match, between players within each position and from team to team, respectively. The study was conducted by means of locomotion match analysis, physiological measurements during match-play and physical testing in Danish male elite TH players. Since the activity patterns of goalkeepers obvious differ markedly from the field players', the physical demands placed on goalkeepers were not included.

METHODS

Elite TH players from the Danish Premier male Team Handball League (DHL) including in particular two top ranked teams were recruited for the experiments and examined over a six-year period. All players were fully informed of all experimental procedures before giving their written informed consent to participate. The conditions of the study were approved by the local ethics committee. The physical characteristics of the players from the two top ranked teams (9 wing players (WP), 7 backcourt players (BP), 7 circle runners (CR) and 3 goalkeepers (G), n=26) were 26.4±3.1 years, 188.9±6.3 cm and 90.9±9.0 kg with 7.2±3.6 years of playing experience at senior elite level (group means±SD), respectively.

Observations during match-play - video recording

The match activities were video-filmed in such a manner that one camera followed one player close up without interruption throughout the entire course of the match. A total of 240 video recordings were obtained in 62 full-length tournament matches in DHL. For the recorded data to be included in the study, effective playing time for the whole match had to be 42 min or more (i.e. ~70 % of total effective playing time (TPT)) with an effective playing time in one half of the game of 18 min or more (i.e. ~60 % of TPT). A total of 82 recordings were usable and were analyzed according to the established criteria. Field-players were divided into three categories in both offence and defence, namely WP, BP and CR, respectively. A total of 8 locomotive categories were registered. Total distance covered (TDC) during a match was calculated as the sum of the distances covered during each type of movement. The movement categories were standing still (0 km·h⁻¹), walking (4 km·h⁻¹), jogging (8 km·h⁻¹), running (13 km·h⁻¹), fast running (17 km·h⁻¹), sprinting (24 km·h⁻¹), sideways movement (10 km·h⁻¹) and backwards running (10 km·h⁻¹). The selected speeds were the same for all players. To ensure a high reproducibility, the computer based analysis of TH was conducted by the same observer, who was experienced with this type of analysis.

Physiological measurements during match-play

The physiological work load during tournament matches was registered by continuous HR monitoring in successive 5-s intervals. Both prior to the game, after half time and at the end of the game blood samples were obtained in selected players to measure the blood lactate concentration (BLC) and the players were weighted. At the same time, their intake of fluids during the match including the half-time were extensively controlled and measured. Hence, their total intake of fluid and their total weight loss could be calculated.

Physical tests - laboratory testing

An incremental treadmill running test was performed, which consisted of a submaximal test followed by an exhaustive incremental maximal test. Respiratory measurements were conducted using online analysis. HR was continuously recorded in 5-s intervals throughout the test using a HR monitor. The individual HR-VO₂ relationship obtained during the treadmill test was used to estimate VO₂ during match-play based on the players HR during match-play. Subsequently, RWL during match-play expressed as % of VO₂-max could be determined. Blood samples were taken from a catheter with heparinised syringes. Maximal concentric, isometric and eccentric muscle strength was determined for the knee extensors and flexors using isokinetic dynamometry as previously described in detail elsewhere (Thorlund et al. 2008).

Field testing

A variety of jump tests were performed including counter movement jumping (CMJ), “jump and reach” test with run-up as well as standing 5-step jumps. The ability to perform high-intensity intermittent running were assessed using the Yo-Yo intermittent recovery test, level 2 (YIR2-

test), as described by Bangsbo et al. (2008). The ability to carry out repeated sprints was tested using a repeated sprint test, in which players sprinted maximally 7 x 30 meters with 25 seconds of low-intensity running in between. From this a fastest time, a mean time and a so-called fatigue time were identified. This latter time is the difference between the fastest and the slowest times and provides an estimate of the player's ability to recover after maximal work. Maximal ball throwing speed was measured in each player using Doppler radar during a variety of shots. A pre-study familiarization test round that included all test types was performed in all players. All results are presented as group mean values \pm standard deviations (SD). The level of significance was set at $p < 0.05$ using two-tailed testing.

RESULTS

Locomotion match analysis

Table 1. Offensive and defensive actions per match for all players combined ($n=82$) in the eight movement categories in the locomotion match analysis. Results are mean \pm SD.

Offensive and defensive actions combined for the entire match				
	Playing time per match (s)	% of total playing time per match	Distance covered (m)	% of distance covered
Standing still	1190 \pm 277	36.8	0	0
Walking	1281 \pm 233	39.6	1423.6 \pm 265.3	39.2
Jogging	279 \pm 70	8.6	617.6 \pm 155.1	17.0
Running	141 \pm 34	4.4	510.1 \pm 120.7	14.1
Fast running	44 \pm 18	1.4	207.1 \pm 91.3	5.7
Sprinting	12 \pm 11	0.4	78.3 \pm 91.4	2.2
Sideways movement	240 \pm 87	7.4	666.3 \pm 242.4	18.4
Backwards running	44 \pm 27	1.4	124.0 \pm 76.3	3.4
Total	3231 \pm 352	100	3627.0 \pm 568.4	100
Offensive actions for the entire match				
	Playing time per match (s)	% of total playing time per match	Distance covered (m)	% of distance covered
Standing still	480 \pm 159	30.5	0	0
Walking	746 \pm 139	47.5	829.2 \pm 159.7	44.9
Jogging	128 \pm 46	8.1	283.8 \pm 102.6	15.4
Running	64 \pm 19	4.0	229.3 \pm 69.4	12.4
Fast running	23 \pm 11	1.5	110.4 \pm 52.2	6.0
Sprinting	8 \pm 8	0.5	50.8 \pm 49.7	2.8
Sideways movement	94 \pm 51	6.1	264.9 \pm 134.6	14.3
Backwards running	28 \pm 18	1.8	77.4 \pm 52.4	4.2
Total	1571 \pm 188	100	1845.8 \pm 346.2	100
Defensive actions for the entire match				
	Playing time per match (s)	% of total playing time per match	Distance covered (m)	% of distance covered
Standing still	710 \pm 173	42.8	0	0
Walking	535 \pm 140	32.2	594.4 \pm 161.7	33.4
Jogging	151 \pm 38	9.1	333.8 \pm 85.4	18.7
Running	77 \pm 25	4.7	280.8 \pm 91.6	15.8
Fast running	21 \pm 11	1.2	96.7 \pm 50.4	5.4
Sprinting	4 \pm 4	0.3	27.5 \pm 31.1	1.6
Sideways movement	146 \pm 59	8.7	401.4 \pm 163.7	22.5
Backwards running	16 \pm 12	1.0	46.6 \pm 32.9	2.6
Total	1660 \pm 251	100	1781.2 \pm 336.8	100

Mean TPT for all analyzed players ($n=82$) was 53.85 \pm 5.87 min. Standing still and walking constituted 76.5 \pm 10.4 % of TPT per match. In contrast, the amount of high-intensity running (HIR), which consisted of fast running and sprinting, constituted 1.7 \pm 0.9 % of the TPT per match corresponding to 7.9 \pm 4.9 % of TDC per match (Table 1). The number of high-intensity runs was 53.3 \pm 14.2 for all players combined. Mean TDC were 3627.0 \pm 568.4 m. Positional differences were observed. Both BP (3764.7 \pm 532.2 m, $p < 0.05$) and WP (3641.1 \pm 601.2 m, $p < 0.05$) performed a greater mean TDC per match than CR (3295.2 \pm 495.3 m). Full-time players

(n=13, mostly BP) performed a greater mean TDC (3944.5±538.3 m, p<0.05) compared to non-full-time players (3567.2±513.7 m, n=69). WP performed more HIR (10.9±5.7 % of TDC) than both CR (8.5±4.3 %, p<0.05) and BP (6.2±3.2 %, p<0.01). Separated in offence and defence, clear positional differences were demonstrated. WP performed in both cases more HIR than CR and BP. No differences were observed between matches of varying importance.

Physiological measurements during match-play

Mean HR during active playing on the court (n=41) was 163.1±5.3 (beats·min⁻¹). RWL during match-play was found to be on average 70.85±6.00 % of VO₂-max for all players combined. However, considerable individual variations in RWL were observed, since players typically showed transient periods with a RWL corresponding to over 90 % of VO₂-max, while at other times they performed with a load below 50 % of VO₂-max. Positional differences were demonstrated, where CR (73.80±5.87 of VO₂-max) and WP (73.15±5.92 of VO₂-max) played with a higher (p<0.05) RWL than BP (67.92±5.55 of VO₂-max). Mean BLC in capillary blood for selected players (n=38) before the match, after half time and at the end of the match were 1.49±0.46, 3.73±1.59 and 4.82±1.89 mM, respectively, with individual post match values ranging from 2.84 to 10.81 mM. Mean intake of fluid and loss of weight for selected players (n=21) after half time, after the second half and in total after the entire match were 0.61±0.20 l and 0.45±0.23 kg, 0.59±0.31 l and 0.36±0.21 kg and 1.20±0.43 l and 0.81±0.41 kg, respectively.

Physical tests

Table 2. Results from (a) different practical jump tests, (b) measuring of maximal throwing speed for different types of shots (c) the repeated sprint test in Danish male elite Team Handball players (n=26). Results are mean ± SD. The variation area is indicated in brackets.

	All player combined (n=26)	Wing players (n=9)	Circle runners (n=7)	Backcourt players (n=7)	Goalkeepers (n=3)
(a) CMJ height (cm)	43.9 ± 6.0	46.4 ± 3.5 **	41.0 ± 3.2	42.1 ± 4.3	47.5 ± 3.4 *
CMJ height with ½ BW (cm)	24.4 ± 2.2	24.4 ± 2.1	25.0 ± 3.4	23.8 ± 2.6	24.3 ± 2.2
Jump and reach (cm)	71.4 ± 7.8	74.5 ± 7.1	69.8 ± 5.2	70.1 ± 7.5	68.9 ± 6.7
Standing 5-step jump (m)	13.39 ± 0.70	13.21 ± 0.86	13.43 ± 0.66	13.46 ± 0.68	13.65 ± 0.70
(b) Set shot without run up (km·h ⁻¹)	86.8±6.4	88.6±5.5	78.5±4.9 #	92.3±7.1	87.6±8.8
Set shot with run up (km·h ⁻¹)	92.8±5.3 *	95.7±5.8	84.3±5.7 €	98.6±7.3	90.4±7.6 ^π
Running shot (km·h ⁻¹)	86.1±5.5	87.5±4.4	80.8±4.5 €	90.8±6.9	83.6±9.3
Jump shot (km·h ⁻¹)	84.2±5.2	86.0±5.0	79.6±5.9 €	90.2±6.3	75.5±4.9 ^α
(c) Fastest time (s)	4.09 ± 0.12 (3.87 - 4.28)	4.05 ± 0.12 # (3.91 - 4.20)	4.10 ± 0.13 (4.01 - 4.21)	4.11 ± 0.12 (3.87 - 4.24)	4.15 ± 0.11 (4.06 - 4.28)
Mean time (s)	4.30 ± 0.13 (4.04 - 4.51)	4.25 ± 0.10 ## (4.09 - 4.49)	4.33 ± 0.13 (4.12 - 4.50)	4.30 ± 0.09 (4.04 - 4.46)	4.34 ± 0.12 (4.22 - 4.51)
Fatigue time (s)	0.33 ± 0.14 (0.07 - 0.58)	0.26 ± 0.14 ## (0.07 - 0.51)	0.37 ± 0.15 (0.14 - 0.56)	0.34 ± 0.11 (0.13 - 0.58)	0.39 ± 0.10 (0.31 - 0.51)

Difference (a) between goalkeepers and circle runners & backcourt players* p<0.05 and between wing players and all other field players ** p<0.05, (b) between wing players and goalkeepers # p<0.05 and between wing players and circle runners & goalkeepers ## p<0.05 and (c) between set shot with run up and all other types of shots * p<0.05, between circle runners and all other playing positions # p<0.05, between circle runners and wing players & backcourt players € p<0.05, between goalkeepers and backcourt players ^π p<0.05 and between goalkeepers and wing players & backcourt players ^α p<0.05.

Mean absolute VO₂-max, relative VO₂-max and Fitness Index for all players combined were 5.02±0.66 (l O₂·min⁻¹), 55.23±4.12 (ml O₂·min⁻¹·kg⁻¹) and 186.62±18.21 (ml O₂·min⁻¹·kg^{-0.73} ml), respectively. VO₂-max (ml O₂·min⁻¹·kg⁻¹) did not differ between playing positions neither when expressed as Fitness Index (ml O₂·min⁻¹·kg^{-0.73}). Mean running speed at a BLC of 4 mM was 12.90±1.79 km·h⁻¹ for all players combined. The knee extensors were stronger (p<0.01) than the knee flexors (primarily the hamstrings) at all angular velocities except at concentric work at

240°·s⁻¹ and 30°·s⁻¹ (50°). No relationship was found between the isolated strength capacity and the others parameters investigated. Selected results from the field testing are presented in Table 2. Differences emerged between various playing positions. Mean total running distance for all players combined (n=26) in the YIR2-test was 895±184 m with positional differences (p<0.05) as WP (975±123 m) ran longer than BP (897±108 m), CR (827±264 m) and G (807±205 m), respectively.

Differences between first and second half of the match

There was no decrease in mean TDC from the first (1837.9±234.6 m) to the second half of the match (1789.1±231.7 m), while the amount of HIR for all players combined was lower (p<0.05) in the second (130.4±45.4 m) than in the first half (155.3±57.6 m) corresponding to a decrease of 16.2 %. RWL and mean distance covered (MDC) during match-play are depicted in figure 1.

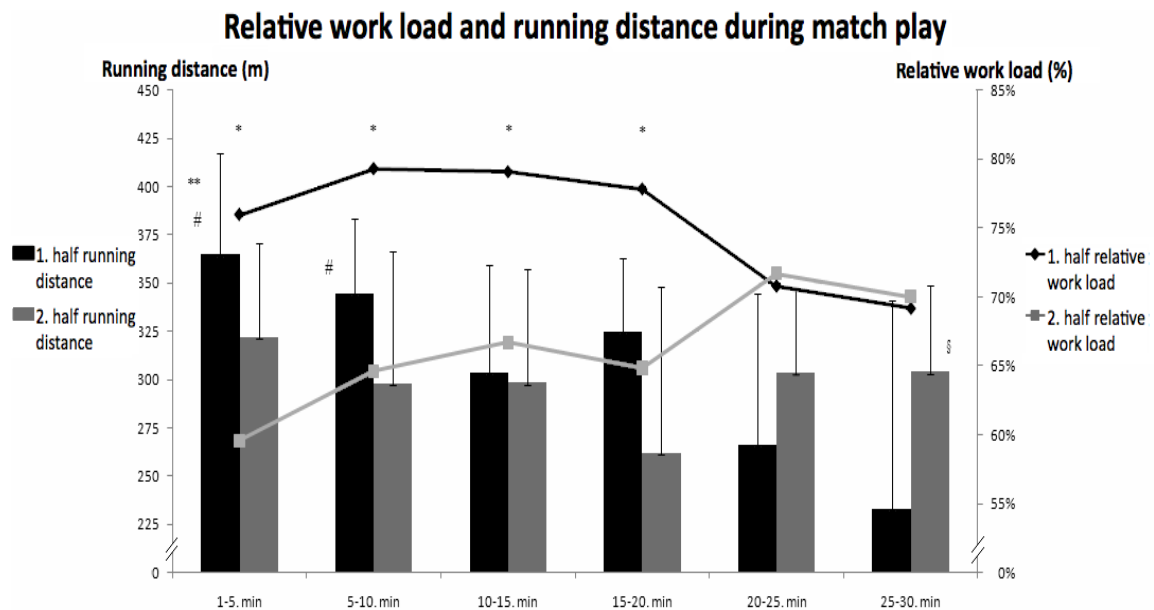

Figure 1. The relative work load during match-play expressed as % of VO₂-max. (dark line: 1.half, grey line: 2.half) and the distance covered in successive 5-min intervals during the first half and second half time periods, respectively (black bars: 1.half, grey bars: 2.half). Results are mean ± SD (n=41). Higher relative work load than in the corresponding time period in the second half * p<0.05. Longer distance covered in first half compared to the corresponding time period in second half ** p<0.05. Longer distance covered in first two 5-min intervals in first half than the last two 5-min intervals in first half # (p<0.05). Longer distance covered in the last 5-min of second half compared to the corresponding time interval in the first half § p<0.05.

DISCUSSION

In the present study, mean TDC was 3627 m with a mean TPT of 53.85 min. Previous studies were based on results obtained in 11 matches or less. Analyzing the present results (62 matches, 82 analyzed players from several different teams) may therefore provide a more valid estimate of male elite TH players' TDC during match-play. A RWL during match-play ~70 % indicates that elite TH places moderate-to-high demands on the player's aerobic energy production, but it does not seem to be a pivotal factor for physical performance. That HIR only constituted in average ~2 % of TPT per match does not mean that HIR is not important in modern male elite TH. Potentially, a large high-intensity running capacity may be of substantial importance on the outcome of a match. Mean duration of a sprint was 1.02 s. This indicates, although the mean sprint time also covers sprinting in other situations than fast break, that a fast break typically is not a maximum sprint all the way up the court (about 3-4 s). In TH it is important to react quickly and perform powerful changes in direction, while moving quickly over short distances.

When successive 5-min intervals in the two halves were analyzed, the results indicated that nearly full-time players (≥ 50 min) may experience temporary muscle fatigue and impaired physical performance and recover through periods of less amount of locomotion and then tactically and physically use this to make an all-out performance in the end of the match (Figure 1). The BLC values revealed that the rate of muscle lactate production is high during an elite TH match and supports the present findings that fatigue might occur in elite TH. MDC and RWL were higher in the first 5 min of the first half than in the corresponding first 5 min of the second half. A possible reason for this may be a different preparation for the two halves. The 15 min break is probably long enough for the muscle temperature to drop, so running performance is inhibited in the initial phase of the second half. It may be advantageous for elite TH players to perform re-warm-up activities in the half time in an appropriate extent. Notably, for all types of shots examined the present speeds were higher than for Danish National Team players tested 35 years ago (Mikkelsen & Olesen, 1976), who used the same equipment and methodology as in our study. This indicates greater muscle power or better technique in elite players of today. Marked positional differences in the physical demands were observed in accordance with previous studies in DHL (Tanaka et al., 2002). The present results combined with previous study data thus suggest that running training in male elite TH should be more individually planned instead of the traditional collective way.

CONCLUSIONS

In conclusion, modern male elite TH is a physically demanding intermittent team sport, which during match-play places moderate-to-high demands on intermittent endurance running capacity and where the anaerobic energy turnover may be very high in brief time intervals. Although high-intensity running did not per se represent much of TPT, the ability continuously to change pace and accelerate throughout the entire match appear to be of high importance for top-level playing performance. Indications of temporary fatigue and impaired physical performance were observed during the game, reflected by the reduced amounts of HIR and decrease in RWL in the second half. Also, major individual differences in the physical demands and physical test results were demonstrated between playing positions. Consequently, modern male elite TH should comprise physical training that is adjusted to the specific playing position as well as to the players' individual physical capacity and need to recover. In addition, an increased focus on improving high-intensity intermittent exercise capacity also seems relevant. The current findings provide valuable information about activity patterns in male elite TH players, which may be useful in the development of position-specific training regimens.

LBMichalsik@health.sdu.dk

TECHNICAL ACTIVITY PROFILE AND INFLUENCE OF BODY ANTHROPOMETRY IN MALE ELITE TEAM HANDBALL PLAYERS

Lars Bojsen MICHALSIK¹, Per AAGAARD², Klavs MADSEN¹

¹Aarhus University, Aarhus, Denmark ² University of Southern Denmark, Odense, Denmark

SUMMARY

The present study showed that modern male elite Team Handball (TH) is a physically demanding game characterized by a high number of short-term, high-intense technical playing actions, which are performed intermittently throughout the entire match. Findings indicated that temporary fatigue may occur. Physical demands differed between playing positions. Body anthropometry seems to have an important influence on playing performance at the various playing positions.

Keywords: *Technical match analysis, physical confrontations, body anthropometry, positional differences, player characteristics*

INTRODUCTION

Although the game of TH is over a century old, it has continued to develop over the years, during which the demands for elite players have also changed. The amount of training has increased considerably along with an elevated intensity of the game, which has contributed to the increase in physical demands on the players. Based on this development in the game, it is particularly relevant to try to identify optimal training regimens in present-day elite TH players. Thus, it is necessary to conduct a complete working demand analysis of the game, since knowledge of the working requirements is a prerequisite for the planning and implementation of optimal training (Michalsik, 2004).

The game of TH contains many other physical demands besides just running. Tackles, shots, fakes, blocks, side-cuttings etc. are all technical actions, which are inherent in modern TH, but these factors and their relative share of the total working demands are not well documented. To our best knowledge no data have been published on the technical characteristics of elite TH players. Moreover, it seems relevant to investigate if differences in physical demands exist between various playing positions. If this is the case, physical training should be conducted more individually rather being based on a collective training regime, where all players perform identical types of exercise. Furthermore, it is still unknown whether the performance of elite TH players is inhibited during match-play due to fatigue. Information about fatigue or reduced physical performance is highly relevant when planning and executing physical training in elite TH. Finally, it may be of interest to examine the body anthropometry (BA) of elite TH players, since previous studies have showed that BA appears to have an important influence on playing performance in male elite TH. However, this aspect has not previously been fully examined in relation to specific playing positions.

The aim of the present study, therefore, was to (i) determine the physical demands imposed on male elite TH players, (ii) to identify any positional differences in physical demands and body anthropometry, and (iii) to examine whether fatigue occurs during an elite TH match. As substantial differences in activity pattern may occur from team to team and match to match and between players of different playing positions, respectively, it is crucial to include a large number of players from various teams representing all playing positions to fully investigate these aspects of TH. The study was conducted by means of technical match analysis and anthropometric measurements in Danish male elite TH players. It is well known that the activity patterns of goalkeepers (G) is

considerably different from the field players', therefore the physical demands placed on G were not included.

METHODS

Elite TH players from the Danish Premier male Team Handball League (DHL) including particularly two top ranked teams participated as experimental subjects in the study and were examined over a six-year period during. All players were fully informed about the experimental procedures and possible discomforts associated with the study before giving their written informed consent to participate. The conditions of the study were approved by the local ethics committee.

Observations during match-play - video recording

Competitive games were taped in such a manner that one camera followed one player close up without interruption throughout the entire course of the match. Altogether 62 full-length tournament matches in DHL were video-filmed, which provided a total of about 240 recordings. For the recorded data to be included in the study, effective playing time for the whole match had to be 42 min or more (i.e. ~70 % of total effective playing time (TPT)) with an effective playing time in one half of the game of 18 min or more (i.e. ~60 % of TPT). A total of 82 recordings fulfilled these conditions and were analyzed according to established criteria. Field-players were divided into three categories in both offence and defence, wing players (WP), backcourt players (BP) and circle runners (CR), respectively. Since TH involves a great deal of physical contact, technical match analysis of each game was conducted to avoid an underestimation of the quantity of movement. Since no studies so far have reported about a complete technical match analysis in elite TH, we developed a specific analysis program for the technical match analysis in TH (Riise et al., 2006). A total of 6 types of playing actions were registered. The playing actions comprised shots, breakthroughs, fast breaks, tackles, technical errors and defence errors. Each playing action was further divided into a number of sub-categories, all of which were precisely defined. To ensure consistency and reproducibility, the repeated video analysis was conducted by the same observer, who was experienced with this type of analysis.

Body anthropometry

Anthropometric data (body height (BH), body mass (BM)) were obtained in all players from the two top ranked clubs (n=26) in connection with physical tests. In addition, BA and player characteristics in the remaining teams of DHL were investigated by a questionnaire survey in the first season (n=157) and in the fifth season (n=191), respectively. Here, individual players informed about their BH, BM, age, playing position and playing experience at senior elite level. All results are presented as group mean values \pm standard deviations (SD). The level of significance was set at $p < 0.05$ using a two-tailed test design.

RESULTS

Technical match analysis

Technical match actions varied between different playing positions (Table 1). Notably, WP had markedly less body contact than BP and particularly CR. BP performed considerably more jump shots than any other form of shots ($p < 0.001$). A reduced MSP was observed ($p < 0.05$) using underhand shots (21.4 %), and there was a tendency ($P = 0.09$) for higher MSP by penalties (63.4 %) compared to all other types of shots. There was a higher ($p < 0.05$) MSP using free shots (57.0 ± 27.8) compared to shots, where the players concurrently received a hard checking (33.4 ± 29.6). In contrast, no difference to light checking's (45.1 ± 30.2) was observed. There was no difference in MSP depending on court position (where the take-off is carried out) although there was a tendency ($P = 0.07$) of a higher MSP in shots from the 6 m line (53.5 ± 26.9) compared to shots from further

away from the goal (~ 41 %). There were some differences, but no clear picture in the mean number of technical actions both in offence and in defence between matches of different importance.

Table 1. Offensive and defensive actions, respectively, in total for the first and the second half, for the different playing positions and for all players combined. Results are mean \pm SD.

Offensive actions - 1. half and 2. half in total				
Positional differences				
Play actions	All players combined (n=82)	Wing players (n=23)	Circle runners (n=18)	Backcourt players (n=41)
	Number per match	Number per match	Number per match	Number per match
Playing time (min)	26.18 \pm 3.13	26.52 \pm 3.55	26.12 \pm 2.68	26.02 \pm 3.10
Offensive breakthroughs	1.5 \pm 1.4	1.2 \pm 1.2	1.0 \pm 0.5	1.8 \pm 1.3
Fast breaks	6.0 \pm 4.2	8.9 \pm 3.1*	8.3 \pm 4.0	3.4 \pm 3.2 ^{π}
Technical errors	1.5 \pm 1.3	1.2 \pm 0.9	1.6 \pm 1.2	1.5 \pm 1.7
Hard checking	7.5 \pm 4.4	4.3 \pm 2.1*	11.6 \pm 3.2#	7.5 \pm 2.7 ^{π}
Light checking	27.0 \pm 18.4	10.6 \pm 2.3*	58.9 \pm 20.3###	22.2 \pm 10.0 ^{$\pi\pi$}
Clasping	2.7 \pm 1.9	1.2 \pm 0.9	6.1 \pm 2.9###	2.1 \pm 1.5 ^{$\pi\pi$}
Screenings	4.8 \pm 8.3	0.4 \pm 0.7*	16.7 \pm 9.6###	2.2 \pm 4.3 ^{$\pi\pi$}
Shots	8.5 \pm 4.2	6.0 \pm 2.5***	7.0 \pm 2.0	10.5 \pm 3.4 ^{π}
Scoring Percentage	44.9 \pm 17.7	46.9 \pm 23.9	48.8 \pm 24.2	42.0 \pm 14.6
Defensive actions - 1. half and 2. half in total				
Positional differences				
Play actions	All players combined (n=82)	Wing players (n=23)	Circle runners (n=18)	Backcourt players (n=41)
	Number per match	Number per match	Number per match	Number per match
Playing time (min)	27.67 \pm 4.18	26.28 \pm 2.40*	27.08 \pm 2.42	28.70 \pm 2.80
Hard checking	5.8 \pm 3.6	4.9 \pm 3.3	6.6 \pm 3.2	6.0 \pm 3.3
Light checking	24.1 \pm 12.6	14.6 \pm 5.9*	33.7 \pm 12.4###	25.2 \pm 7.3 ^{π}
Clasping	3.9 \pm 3.0	1.3 \pm 1.1**	8.2 \pm 5.0###	3.5 \pm 2.0 ^{π}
Screenings	6.1 \pm 7.7	0.9 \pm 1.5****	12.4 \pm 7.4###	6.3 \pm 3.7 ^{π}
Blocks	3.7 \pm 3.5	0.2 \pm 0.4****	5.5 \pm 3.2###	4.9 \pm 2.8
Defensive errors	3.8 \pm 2.5	3.0 \pm 2.2	5.4 \pm 1.8#	3.7 \pm 2.3

Difference between wing players and backcourt players * p<0.05, ** p<0.01, *** p<0.005 and **** p<0.001, between wing players and circle runners # p<0.05 and ## p<0.001, between circle runners and backcourt players ^{π} p<0.05 and ^{$\pi\pi$} p<0.001.

Differences between first and second half of the match

Either a tendency or significant decrease in the number of the most important playing actions was observed both in offence and in defence from the first to the second half. Notably, in defence all players combined gave less hard and light checking's in the second half (p<0.05). In offence, CR received less hard and particularly light checking's, performed less fast breaks and committed more technical errors in the second half compared to the first (p<0.05). On average, each player performed 36.9 \pm 13.1 high-intense playing actions (HPA) per match.

Anthropometric characteristics of elite TH players

In DHL in two selected seasons in total (n=348), mean BH and BM were 189.6 \pm 5.8 cm and 91.7 \pm 7.5 kg, respectively, while mean age and EPE were 26.1 \pm 3.9 years and 7.3 \pm 4.5 years, respectively. Differences were observed between various playing positions, and the picture was the same in the two seasons. WP were lighter, smaller, younger and less experienced on senior elite level than the rest of the players including G. In contrast, CR were heavier and taller than the rest of

the field players. Whether a relationship exists in TH between individual playing time and BA, age and experience, respectively, can be illustrated by comparing first and second choice players in the various playing positions (Table 2). For all players combined, there were no differences in mean BH and BM between the two choices of players, but first choice players were older and more experienced than second choice players ($p < 0.001$). A similar pattern was observed between Danish and foreign players (FP). FP constituted in the two seasons in total 13.9 % of the total number of players. Most of the players in the fifth season were between 23 and 28 years old (45.8 %). In addition, this age group comprised the highest percentage of players, who were selected first choice (48.7 %). For the different playing positions, WP had the highest percentage of players under 23 years (26.1 %) and the lowest proportion of players over 28 years (9.2 %). Conversely, G showed the highest percentage of players over 28 years (52.0 %) and the lowest percentage of players less than 23 years (12.2 %) and none of latter players were selected first choice. No relationship was observed between team rankings in DHL in the fifth season and BH, BM and age, respectively.

Table 2. Age, body height, body mass and senior elite playing experience for first choice and the second choice players for all players combined and for the different playing positions inclusive goalkeepers in the entire Danish Premier male Team Handball League in the fifth season. Results are mean \pm SD.

Body anthropometry				
The entire Danish Premier male Team Handball League in the fifth season				
Difference between first choice and second choice players				
	Age (years)	Body height (cm)	Body mass (kg)	Senior elite playing experience (years)
All players combined (n=191)	26.0 \pm 4.4	190.3 \pm 6.1	92.6 \pm 8.5	7.3 \pm 4.4
1.choice (n=105)	27.1 \pm 3.9 #####	190.6 \pm 6.6	92.9 \pm 8.2	8.4 \pm 3.7 #####
2.choice (n=86)	24.7 \pm 4.6	189.9 \pm 5.5	92.3 \pm 8.9	6.0 \pm 4.0
Wing players (n=52)	24.9 \pm 3.9 **	184.9 \pm 5.7 *	84.5 \pm 5.8 *	6.5 \pm 4.0 **
1. choice (n=30)	26.4 \pm 3.6 #####	184.2.1 \pm 6.1	84.3 \pm 5.5	7.9 \pm 3.7 ###
2.choice (n=22)	22.7 \pm 3.3	185.8 \pm 5.1	84.7 \pm 6.1	4.5 \pm 3.6
Circle runners (n=33)	26.2 \pm 5.0	194.8 \pm 3.6 π	99.4 \pm 6.2 $\pi\pi$	7.4 \pm 5.2
1.choice (n=20)	26.6 \pm 3.8	195.1 \pm 3.9	98.9 \pm 5.2	7.9 \pm 2.1
2.choice (n=13)	25.6 \pm 4.3	194.7 \pm 3.4	100.4 \pm 7.5	6.6 \pm 3.5
Backcourt players (n=80)	25.8 \pm 3.6	191.9 \pm 5.4	94.7 \pm 7.1	7.3 \pm 3.9
1.choice (n=42)	26.9 \pm 3.1 ###	192.7 \pm 5.2	95.7 \pm 5.8	8.4 \pm 3.4 ###
2.choice (n=38)	24.5 \pm 3.8	190.9 \pm 5.5	93.2 \pm 8.1	5.9 \pm 4.1
Goalkeepers (n=26)	28.5 \pm 5.6 ***	190.8 \pm 4.2	94.1 \pm 7.9	9.5 \pm 5.4
1.choice (n=12)	30.2 \pm 4.3 ##	191.8 \pm 4.9	94.2 \pm 9.1	11.0 \pm 3.3 #
2.choice (n=14)	27.0 \pm 3.2	190.0 \pm 3.4	94.0 \pm 7.0	8.0 \pm 4.1
Danish players (n=163)	25.6 \pm 4.4 €€	190.1 \pm 6.0	92.0 \pm 8.2 €	7.0 \pm 4.2 €€€
Foreign players (n=28)	27.9 \pm 3.9	191.6 \pm 6.9	96.1 \pm 9.8	9.6 \pm 4.2

Difference between wing players and all other playing positions * $p < 0.001$, between wing players and G ** $p < 0.05$, between G and backcourt players *** $p < 0.05$, between circle runners and all other playing positions π $p < 0.05$ and $\pi\pi$ $p < 0.01$, between first choice and second choice players # $p < 0.05$, ## $p < 0.01$, ### $p < 0.005$ and #### $p < 0.001$ as well as between Danish and foreign players € $p < 0.05$, €€ $p < 0.01$ and €€€ $p < 0.005$.

DISCUSSION

Technical activity profile

The present study showed that the players were highly active with many physical confrontations, which probably require a high level of muscle strength, explosiveness (rate of force development, RFD) and mobility. Due to their short duration and very high intensity, a number of these technical actions likely placed high demands on the anaerobic energy production. The amount of technical data from previous studies of TH is highly limited. MSP was found to drop significantly in players who received a hard checking. It is therefore highly crucial for the defence to sustain hard checking's throughout the entire match. The most conspicuous difference between the various playing positions was that WP had significantly fewer physical confrontations with the opponents than BP and in particular CR. Players worked intensely for short, interrupted periods in alternation with walking, running, sprinting, moving forwards and backwards and side-stepping, while frequently being tackled, grappled and pushed. Based on the number of HPA, somewhat higher anaerobic demands likely were placed on players, who played WP in offence and who covered BP in defence than players, who played BP in offence and covered WP in defence (cf. Table 1). The present study provided direct evidence that clear positional differences in the physical demands exist during male elite TH match-play. The observed decrease in the number of different playing actions from the first to the second half supported the results from the locomotion match analysis (Michalsik et al., 2011) and indicates that temporary fatigue and impaired physical performance may occur in male elite TH at least in some players. Furthermore, the technical match analysis showed no clear indications that match importance had an influence on the amount of specific technical playing actions in a game.

Body anthropometry

Notably, over the past decades the players have become progressively higher and heavier with probably increased muscle mass. Mikkelsen & Olesen (1976) determined the mean BH and BM in elite players to be 185.4 cm and 82.3 kg, respectively. 25 years later, the mean BH and BM were around 190 cm and 93 kg, respectively. Great BH is a clear advantage in several game situations such as when shots are performed from a long distance from the goal as showed by Wagner et al. (2010), who demonstrated that taller TH players have the ability to achieve a higher ball release speed in the jump throw. In due proportion with the player's BH, the problems with coordinative and speed capabilities increases. For this reason, it is advantageous to compose a team not only exclusively of tall players, but also with somewhat smaller players with other abilities. This is important because the influence of BH differs at various playing positions. The results from the present study confirm the gradual development of today's tall and heavy male elite TH players with large muscle mass. It seems desirable to develop players that are heavy and strong in breakthroughs and hard to push away, while at the same time during an entire game can perform fast running and side stepping actions combined with a great mobility both in offence and defence. Several clear positional differences in BA were demonstrated, but also individual variations were observed within each playing position. A consistent relationship between BA and the position specific physical requirements were observed.

WP were younger and had less playing experience than the rest of the players including G. Since it takes quite a lot of time to build up a large muscle mass and physical strength, it is only understandable that WP were younger than the rest of the players, because the need for high muscle strength in physical confrontations were much less important for WP. Furthermore, WP were not that much involved in the organised play compared to the other playing positions, so it was less risky to have an inexperienced player on this position. For all players combined and for the different playing positions except for CR, first choice players were consistently older and more experienced than second choice players. In addition, G were significantly older than the rest of the players

indicating that experience plays an important role for the performance of all kind of players, but especially for G. A crucial factor for G seems to be the acquisition of routine that comes with age, so that he gains substantial experience in how to react appropriately towards specific forms of shot from various playing positions. G in particular seems to be able to compensate for a decrease in physical shape, what may come with age, with great experience because of the highly special demands of this playing position. For all players combined in the fifth season, the majority of players were between 23 and 28 years of age. In addition, this age group contained the highest percentage of players selected first choice. This indicates that playing experience may be important in modern male elite TH, but in relation to age this may be neutralized by the importance of a sufficient physical shape to cope with the physical demands.

CONCLUSIONS

In conclusion, the present study demonstrates that modern male elite TH is a physically demanding and complex game which comprises numerous technical playing actions, which are conducted with short duration and high intensity intermittently throughout the entire match. The observed decline in the amount of playing actions in the second half indicated that temporary fatigue and impaired physical performance may occur at least in some players. Considerable positional differences in the physical demands were observed. Due to the nature of the game of TH as a physically demanding contact sport, body anthropometry appears to play a crucial role for playing performance at the various playing positions.

PERSPECTIVES

The substantial positional differences in the physical demands, which were revealed in the present study, challenge the traditional way of conducting physical training in modern TH. Consequently, differential and specific physical training in male elite TH should be implemented at the various playing positions to ensure optimal development of the physical capacity of the individual players. Such individualized training may be divided into separate exercises related to the specific requirements in defence and offence, respectively. Due to the apparent high demands in e.g. acceleration capacity, RFD, fast and hard shots, rapid side cutting manoeuvres and the high number of strength demanding physical confrontations (i.e. pushing and holding), an increased focus on strength training and also on anaerobic training aspects would seem highly relevant.

Significant anthropometric development has taken place in male elite TH, since today's players are markedly taller and heavier than players 30 years ago. Alongside the anthropometric development it is important for the players to be able to maintain or even improve functional characteristics such as acceleration capacity, ability to perform rapid changes of direction, maximum jump height and mobility as well as intermittent endurance running capacity on the playing court despite their larger and heavier body. Therefore, specific physical training targeting these performance components should be employed to optimize the functional capacity in modern male elite TH. The increased knowledge regarding the physical demands of male elite TH players is important for recommendations for the future planning and execution of physical training. Thus, the present findings may be used to design training regimens that can maximize the position-specific physical development in male elite TH players.

LBMichalsik@health.sdu.dk

TECHNICAL MATCH CHARACTERISTICS AND INFLUENCE OF BODY ANTHROPOMETRY IN FEMALE ELITE TEAM HANDBALL PLAYERS

Lars Bojsen MICHALSIK¹, Klavs MADSEN¹, Per AAGAARD²

¹Aarhus University, Aarhus, Denmark ² University of Southern Denmark, Odense, Denmark

SUMMARY

The present match observations demonstrated that female elite Team Handball (TH) players during competitive games intermittently perform a high number and a great variety of short-term, high-intense technical playing actions. No sign of fatigue were observed. Marked positional differences in the physical demands were identified. Findings indicated that body anthropometry have a vital influence on playing performance at the different playing positions.

Keywords: Technical match analysis, physical confrontations, body anthropometry, positional differences, player characteristics

INTRODUCTION

The game of TH is over a century old and like other ballgames, it was from the start a sport for men. In contrast to other sports disciplines women quickly gained interest in the game and started playing TH already in 1905. Female TH was included in the Olympic Games for the first time in 1976. With the progressive development of the TH game over the recent years, the demands imposed on elite players have also changed. The training volume and the number of matches and tournaments have increased significantly, and this supported by with fundamental rule changes in the last decade has contributed to an increase in the dynamics and intensity for the players. Modern elite TH is characterized by sixty minutes of repeated accelerations, sprints, jumps, shots, rapid changes in directions and a high number of body contacts (i.e. checking's etc.) with opponent players. Caused by this marked development in the game, it is a precondition to perform a profound working demand analysis of the game in order to identify the exact requirements for the players on the court, since such prior knowledge provides the needed basis for the planning and execution of effective training (Michalsik, 2004).

The game of TH consists of many other physical demands besides just running. Checking's, shots, fakes, claspings, screenings etc. are all technical actions, which are an integrated part of modern TH and have to be carried out with maximal intensity to overcome opposition, but the relative involvement of these parameters is not well scientifically documented. To our best knowledge no data have been published on the technical characteristics of female elite TH players. Optimal physical working demand analysis includes locomotion match analysis (movement category, intensity, distance) as well as technical match analysis (technical playing actions) (Michalsik & Bangsbo, 2002). An exclusion of one of these analyses will lead to an underestimation of the working demands of the game. In addition, it is also of interest to examine the body anthropometry (BA) of elite TH players, since several studies have found that BA has a decisive impact on the performance in modern elite TH. However, this aspect has not previously been fully evaluated in female elite TH with respect to the various playing positions. Furthermore, it is relevant to identify potential positional differences in the physical demands. If differences exist, physical training in the team sport TH should be planned more individually rather than collectively, where all players perform similar types of training regimens. Finally, it remains unknown whether the playing performance in female elite TH is influenced by the accumulation of fatigue. Knowledge about fatigue or reduced physical performance is highly relevant when planning and implementing the physical training of elite TH players.

The aim of the present study, therefore, was to (i) determine the physical demands placed on female elite TH players and (ii) to identify any positional differences in physical demands and body anthropometry, and (iii) to examine whether fatigue occurs during an elite TH match. Since extensive differences in activity pattern may occur from match to match and between different teams as well as between players of various playing positions, respectively, such investigation must comprise a large number of players from various teams representing all playing positions to fully examine these aspects of TH. The study comprised technical match analysis and anthropometric measurements in a large group of Danish female elite TH players. As the activity patterns of the goalkeeper (G) obvious differ markedly from those of the player on the field, the physical demands placed on G during match-play were not examined.

METHODS

Elite TH players from the Danish Premier female Handball League (DHL) including particularly two top ranked teams participated as experimental subjects in the study and were examined over a five-year period. All players were fully informed about the experimental procedures before giving their written informed consent to participate. The conditions of the study were approved by the local ethics committee.

Observations during match-play - video recordings

Competitive games were taped in such a manner that one camera followed one player close up without interruption throughout the entire time course of the match regardless what the player did. Altogether 46 full-length tournament matches in DHL were video-filmed, which provided a total of about 180 recordings. For the recorded data to be included in the study, effective playing time for the whole match had to be 42 min or more (i.e. ~70 % of total effective playing time (TPT)) with an effective playing time in one half of the game of 18 min or more (i.e. ~60 % of TPT). A total of 84 recordings fulfilled these conditions and were analyzed according to the established criteria.

Field-players were divided into three categories in both offence and defence, wing players (WP), backcourt players (BP) and circle runners (CR), respectively. Since TH involves a great deal of physical contact, technical match analysis of each game was also conducted to avoid an underestimation of the quantity of movement. Since no previous study so far has performed a complete technical match analysis in female elite TH, we developed an analysis program dedicated for technical match analysis in TH (Riise et al., 2006). A total of 6 types of playing actions were registered. The playing actions comprised shots, breakthroughs, fast breaks, tackles, technical errors and defence errors. Each playing action was further divided into a number of sub-categories, all of which were precisely defined. To ensure a high reproducibility, the repeated video analysis was conducted by the same observer, who was experienced with this type of analysis.

Body anthropometry

Anthropometric data (body height (BH), body mass (BM)) were obtained in all players from the two top ranked clubs in DHL (n=26) in connection with physical testing. In addition, BA and player characteristics in the remaining teams of DHL were investigated by a questionnaire survey in the first season (n=120) and in the fifth season (n=157), respectively. Here, individual players reported their BH, BM, age, playing position and playing experience on senior elite level. All results are presented as group mean values \pm standard deviations (SD). The level of significance was set at $p < 0.05$ using a two-tailed test design.

RESULTS

Technical match analysis

Technical match actions differed were between various playing (Table 1). Notably, WP performed considerable more fast breaks and had substantially less body contact than BP and particularly CR.

Table 1. Offensive and defensive actions, respectively, in total for the first and the second half, for the different playing positions and for all players combined. Results are mean \pm SD.

Offensive actions - 1. half and 2. half in total				
Positional differences				
Play actions	All players combined (n=84)	Wing players (n=35)	Circle runners (n=19)	Backcourt players (n=30)
	Number per match	Number per match	Number per match	Number per match
Playing time	24.57 \pm 4.33	24.73 \pm 4.88	24.50 \pm 4.25	24.47 \pm 3.82
Offensive breakthroughs	1.3 \pm 2.2	0.6 \pm 0.8 #	0.2 \pm 0.4 **	2.7 \pm 3.1 π π
Fast breaks	2.8 \pm 2.6	4.4 \pm 2.8 ##	2.5 \pm 1.8 **	1.0 \pm 1.3 π
Technical errors	2.9 \pm 2.3	1.7 \pm 1.6 ##	3.6 \pm 2.2 **	3.9 \pm 2.4
Hard checking	5.0 \pm 4.0	2.2 \pm 1.7 ##	8.4 \pm 3.4 **	6.0 \pm 4.3 π
Light checking	9.6 \pm 6.2	5.3 \pm 3.2 ##	17.0 \pm 5.4 **	9.9 \pm 4.8 π π
Clasping	1.2 \pm 2.0	0.5 \pm 0.9 #	3.0 \pm 3.3 **	0.8 \pm 1.1 π π
Screenings	7.9 \pm 9.8	0.7 \pm 1.7	32.9 \pm 9.9 **	0.5 \pm 1.0 π π
Shots	7.7 \pm 3.7	6.9 \pm 2.9	7.4 \pm 3.3	8.8 \pm 4.6
Scoring percentage	51.9 \pm 21.4	47.5 \pm 20.1	68.0 \pm 17.4 **	46.8 \pm 20.6 π π
Defensive actions - 1. half and 2. half in total				
Positional differences				
Play actions	All players combined (n=84)	Wing players (n=30)	Circle runners (n=19)	Backcourt players (n=35)
	Number per match	Number per match	Number per match	Number per match
Playing time	26.13 \pm 3.83	26.62 \pm 4.07	26.62 \pm 4.30	25.23 \pm 3.28
Hard checking	6.2 \pm 3.8	3.6 \pm 2.6 ##	7.4 \pm 4.3 **	7.8 \pm 3.4
Light checking	14.5 \pm 7.4	8.2 \pm 3.7 ##	20.1 \pm 9.1 **	16.9 \pm 4.4 π
Clasping	1.9 \pm 2.7	0.5 \pm 1.0 ##	4.2 \pm 4.1 *	1.9 \pm 1.9 π π
Screenings	4.2 \pm 5.2	0.5 \pm 1.0 ##	9.3 \pm 6.9 **	4.5 \pm 3.80 π π
Blocks	3.5 \pm 3.8	0.3 \pm 0.7 ##	8.8 \pm 3.3 **	3.3 \pm 2.1 π π
Defensive errors	5.1 \pm 3.2	2.6 \pm 2.4 ##	6.9 \pm 2.9 **	6.2 \pm 2.8

Difference between wing players and backcourt players # $p < 0.05$ and ## $p < 0.001$, between wing players and circle runners * $p < 0.05$ and ** $p < 0.001$, between circle runners and backcourt players π $p < 0.05$ and π π $p < 0.001$.

Differences between first and second half of the match

There were some trends for, but no decreases in the number of the most important playing actions both in offence and in defence from the first to the second half. On average, each player performed 28.3 \pm 11.0 high-intense playing actions (HPA) per match. When in attack, HPA comprise offensive breakthroughs, fast breaks, hard checking's and shots, while in defence HPA comprise hard checking's, clasplings and blocks. With 6 sec. less playing time in the second half, no difference in HPA was found between first and second half (14.6 and 13.8, respectively).

Anthropometric characteristics of elite TH players

In DHL in two selected seasons in total (n=277), mean BH and BM were 175.4 \pm 6.1 cm and 69.5 \pm 6.5 kg, respectively, while mean age and EPE were 25.4 \pm 3.7 years and 7.2 \pm 3.9 years, respectively. Positional differences were observed, and the picture was similar in the two seasons. WP were lighter, smaller, younger and less experienced on senior elite level than the rest of the players including G. In contrast, CR were in the first season heavier and taller than the

rest of the field players. Whether a relationship exists in TH between individual playing time and BA, age and experience, respectively, can be examined by comparing first and second choice players (Table 2). For all players combined, no differences in BH and BM were observed between the two choices of players, but first choice players were older and more experienced than second choice players ($p<0.001$). The same applied in almost all cases for all playing positions. A similar pattern was demonstrated between DP and FP, where FP were older and had more playing experience than DP. FP constituted in the two seasons in total 31.8 % of the total number of players. The majority of players in the fourth season were between 23 and 28 years old (44.6 %). Furthermore, this age group comprised the highest percentage of players, who were selected first choice (48.9 %). For the different playing positions, CR showed the highest percentage of players less than 23 years (44.5 %), while WP had the lowest proportion of players over 28 years (4.9 %). Likewise, WP showed as the only playing position a higher percentage of first choice players in players less than 23 years (20.0 %) compared to players over 28 years (15.0 %). Conversely, G and BP demonstrated the higher percentage of players over 28 years (30.8 % and 34.9 %, respectively) compared to the percentage of players under 23 years (23.1 % and 20.6 %, respectively) and only a small portion of the latter players were selected first choice (6.7 % and 9.5 %, respectively). There was no correlation between team rankings in DHL in the fourth season and BH, BM and age, respectively.

Table 2. Age, body height, body mass and senior elite playing experience for first choice and the second choice players for all players combined and for the different playing positions inclusive goalkeepers in the entire Danish Premier female Team Handball League in the fourth season. Results are mean \pm SD.

Body anthropometry				
The entire Danish Premier female Team Handball League in the fourth season				
Difference between first choice and second choice players				
	Age (years)	Body height (cm)	Body mass (kg)	Senior elite playing experience (years)
All players (n=157)	25.4 \pm 3.6	175.6 \pm 6.2	69.8 \pm 6.6	7.4 \pm 3.8
1. choice (n=94)	26.4 \pm 3.3 €€€	175.9 \pm 6.0	70.1 \pm 6.3	8.5 \pm 3.5 €€€
2. choice (n=63)	24.0 \pm 3.5	175.0 \pm 6.5	69.3 \pm 7.1	5.8 \pm 3.8
Wing players (n=41)	23.7 \pm 2.76 *	169.3 \pm 4.9 β	63.5 \pm 4.8 β	5.4 \pm 3.0 **
1. choice (n=20)	24.84 \pm 3.1 €€	170.1 \pm 4.6	64.3 \pm 5.6	6.6 \pm 3.3 €€
2. choice (n=21)	22.6 \pm 2.1	168.5 \pm 5.1	62.8 \pm 4.0	4.2 \pm 2.2
Circle runners (n=27)	25.1 \pm 3.8	177.7 \pm 4.9	72.5 \pm 4.9	6.8 \pm 3.0
1. choice (n=17)	25.8 \pm 3.4	178.1 \pm 5.5	73.0 \pm 5.4	7.5 \pm 3.1 €
2. choice (n=10)	23.9 \pm 4.3	177.7 \pm 3.8	71.4 \pm 3.7	5.6 \pm 2.4
Backcourt players (n=63)	26.2 \pm 3.4	177.0 \pm 5.4	70.6 \pm 5.3 π	8.5 \pm 3.6 π
1. choice (n=42)	27.1 \pm 3.1 €€	176.2 \pm 5.5	70.3 \pm 5.3	9.5 \pm 3.0 €€
2. choice (n=21)	24.5 \pm 3.4	178.8 \pm 4.7	71.2 \pm 5.3	6.5 \pm 3.9
Goalkeepers (n=26)	26.6 \pm 4.0 α	179.6 \pm 4.1	75.1 \pm 6.1	8.6 \pm 4.0 α
1. choice (n=15)	27.3 \pm 3.8	180.4 \pm 3.9	74.3 \pm 5.2	9.1 \pm 3.7
1. choice (n=11)	25.8 \pm 4.2	178.5 \pm 4.3	76.3 \pm 7.4	7.8 \pm 4.4
Danish players (n=103)	24.7 \pm 3.6 ##	174.6 \pm 6.3 #	69.5 \pm 6.7	6.3 \pm 3.7 ##
Foreign players (n=54)	26.9 \pm 3.1	177.4 \pm 5.8	70.5 \pm 6.5	9.5 \pm 3.2

Difference between wing players and backcourt players * $p<0.01$ and ** $p<0.001$, between wing players and goalkeepers α $p<0.01$, between wing players and all other playing positions β $p<0.001$, between goalkeepers and backcourt players π $p<0.001$, between first choice and second choice players ϵ $p<0.05$, $\epsilon\epsilon$ $p<0.01$ and $\epsilon\epsilon\epsilon$ $p<0.001$ as well as between Danish and foreign players # $p<0.01$ and ## $p<0.001$.

DISCUSSION

Technical analysis

The present study demonstrated that the players were very active both in offence and defence with many intense physical confrontations, which presumably require great strength, explosiveness (rate of force development, RFD) and mobility. These technical actions were performed with short duration and very high intensity and, therefore, most likely involve primarily the anaerobic energy production. The players conduct intensive activities such as combinations of running, sprinting, jumping and throwing and regular in fights with pushing and claspings between the players. Based on the number of HPA, higher anaerobic demands are placed on players, who play WP in offence and who cover BP in defence than players, who play BP in offence and cover WP in defence (cf. Table 1). The amount of technical data from other scientific studies of TH is extremely limited, and they are dealing exclusively with male players. The most obvious positional difference was that WP had markedly less physical confrontations with the opponents than both BP and in particularly CR, which was in accordance with results obtained in male elite TH players from DHL (Michalsik et al., 2011a). Some tendencies, but no significant declines were observed for the various types of playing actions in the second half. This is in contrast with results from the locomotion match analysis (Michalsik et al., 2011b). Apparently, overall movement patterns may be more affected than playing skills (playing actions) by fatigue during match-play.

Body anthropometry

The present results suggested that taller and more powerful players have a clear advantage in female elite TH. However, Hasan et al. (2007) found that Asian female TH players were shorter and had less BM than reported for European female TH players. These findings indicate that it may still be possible in female elite TH to compensate for lack in BH and BM. It is well known that the success of e.g. South Korea in female international TH is based on a selection of relatively small, light, but very fast players with exceptional technical and tactical skills. Marked individual differences in BH are often seen on teams in international female TH. The reason for this is sometimes insufficient player selection, but mostly it is because that key players can compensate the lack of BH by other helpful skills. It may be advantageous to compose a team not only exclusively of tall players, but also with relatively smaller players with other relevant abilities. This is due to the increasing problems with coordination, movement and speed that occur as the BH increases. The latter is especially important since the influence of BH on the playing performance is different in relation to various playing positions. The results from the present study confirm the development of tall and heavy players with a high running ability in female elite TH. A taller BH is an advantage in several game situations such as when effective blocks in defence have to be made and in shots over blocks in offence. A high BM and muscle mass is an advantage in the many physical confrontations with the opponents during match-play, which requires high muscle strength and explosiveness (RFD). However, we observed no correlation between team rankings in DHL (fourth season) and BH and BM, respectively. Thus, other factors than anthropometry appear to have an influence on the success of top-level TH teams. In support of this notion, no difference in BH and BM were found between first choice and second choice players.

The present study demonstrated several major differences in anthropometry between the various playing positions in accordance with the physical demands of specific playing positions. In addition, individual variations in each playing position were found. High muscle strength and explosiveness in many physical confrontations are e.g. the most important physical abilities for CR and BM (muscle mass) has a significant impact on CR's success in offence due to the need to make space for her and the team mates during the many in-fights. High BH in the middle defence to make some effective blocks is also crucial. Compared to male elite TH, the

importance of a high BM and BH on playing performance for CR may be less in female elite players, primarily due to a more mobile style of play in defence and especially in offence, which was reflected in a high total distance covered (Michalsik, 2011b).

Player characteristics showed that WP were younger and less experienced on senior elite level than the rest of the players including G. It may be expected that WP were youngest of all players, since it is less risky to have an inexperienced player on this playing position due to a less involvement in organised play and a reduced need for high muscle strength due to fewer physical confrontations. For all players combined and for all field playing positions, the first choice players were consistently older and more experienced than the second choice players. Further, G were significantly older than WP and CR indicating that especially G seem to be able to compensate for a decline in physical shape, what may come with age, with great experience due to the highly special demands of this playing position. For all players combined (fourth season), the majority of players were between 23 and 28 years. In addition, this age group comprised the highest percentage of players, who were selected first choice. This indicates that this age interval represents the best combination for achieving a high level of playing performance between a significant game experience combined with a great ability to retain a sufficient physical shape.

CONCLUSION

The most important findings of the present study were that female elite TH match-play comprised numerous technical playing actions, which were performed with short duration and high intensity. In addition, substantial positional differences in the physical demands and BA were demonstrated. Moreover, BA seems to have considerable influence on playing performance at the various playing positions. No decline was observed in the amount of playing actions in the second half indicating that permanent fatigue do not seem to occur at the end of the match. The physical demands differed greatly between the various playing positions both in defence and attack. This should lead to an increase in physical training in modern female elite TH directed at specific positions and individual physical capacity. This individual training can be divided into separate physical training related to the specific requirements in defense and attack, respectively. Further, increased focus on strength training also seems to be desirable.

Female elite TH is a highly strenuous body-contact team sport where anthropometry seems to be crucial for the playing performance in the various playing positions. Considerable variations between different playing positions were observed along with individual differences within the same positions. The technical analysis indicated possible causes as to why certain playing positions differ anthropometrically from others. Concurrently with the anthropometric development, it is important for female elite TH players to retain their mobility, speed and aerobic power with the larger and heavier body as they become heavier to push away in a breakthrough and are able to tackle harder in defence. Adequate individualized and all-round based physical training regimens therefore are crucial for performance capacity in modern female elite TH.

LBMichalsik@health.sdu.dk

ACTIVITY MOTOR PATTERN AND HEART RATE DURING ELITE TEAM HANDBALL MATCHES

¹Susana Cristina de Araújo PÓVOAS, ²José Manuel da Costa SOARES,
²António Natal Campos REBELO

¹CIDESD, Maia Institute of Higher Education, Maia, Portugal; ²CIFID, Faculty of Sport, University of Porto, Porto, Portugal

Summary

This study analyses time-motion and cardiovascular demands of top elite male Portuguese handball players during the match. Main results showed that handball is a high demanding intermittent sport despite the amount of time spent in low intensity activities, since high-intensity actions and moments are required throughout the game.

Keywords: *Team handball; time-motion analysis; physiological demands; elite male players.*

Introduction

Handball is an Olympic sport played worldwide and at a highly professional level in many European countries. Nevertheless, unlike other team sports, scientific knowledge regarding elite team handball working demands is scarce. Research on time-motion analysis of handball players during the game often refer to friendly matches and consequently, more studies analyzing official matches are needed. Additionally, no studies have investigated in detail the activity profile throughout the match, including low and high-intensity movements as well as specific handball actions such as turns, stops, jumps, throws, changes of direction and one-on-one situations. Moreover, handball's official rules have changed in 2000, which have been suggested to increase the intensity of the game (Anti et al., 2006; Canayer, 2007; Constantini, 2007). On the other hand, handball involves frequent body contact and several high demanding actions to overcome opposition. Although heart rate (HR) and time-motion are considered valuable and relatively sensitive tools to analyze exercise intensity, analysis of locomotor pattern or HR data alone, may provide incomplete information and can lead to a misinterpretation of the overall working demands of the game. Accordingly, in order to provide more accurate data and to better characterize the activity demands during the game, it would be useful to combine both types of information.

Methods

Subjects

Time-motion and HR analyses were performed on thirty outfield male players (ten of each outfield playing position: wings, backcourt players and pivots; 25.2±3.49 yrs; 186.5±7.92 cm; 87.7±8.96 kg and 9.7±2.25 % fat mass). Participants had at least five years of experience in the top Portuguese handball professional league. All subjects were previously informed of the aims of the study, familiarized with all testing protocols and procedures and delivered writing consents to participate. As dehydration and hyperthermia during the match can influence HR values, body weight and fluid loss were recorded during the matches. Evaluations were made in the middle of competitive period. The training schedule of the teams analyzed included 6–7 training sessions per week. The experimental protocol was approved by the Institutional Review Board and followed the Declaration of Helsinki of the World Medical Association for research with humans.

Procedures

Match Time-motion Analysis

The players were video-filmed during the entire match in order to establish game motion pattern according to methods previously used (Bangsbo, Norregaard, & Thorso, 1991). Players' displacements were coded into eight locomotor categories defined accordingly to Bangsbo et al. (1991) and considering handball's specific movements. The locomotor categories were defined as follows: 1) standing still, 2) walking, 3) jogging, 4) fast running, 5) sprinting, 6) backwards movement, 7) sideways medium-intensity movement and 8) sideways high-intensity movement. The mean velocity of each category was determined by detailed analysis of match images using the lines of the playing court as reference. The distance covered in each category equaled the product of the total time and the mean speed for that activity (Krustrup, Mohr, & Bangsbo, 2002). The total distance covered during a match was calculated as the sum of the distances for each type of activity. High-intensity activities corresponded to the sum of categories 4, 5 and 8 and low-intensity activities were the sum of categories 1, 2, 3, 6 and 7. In addition, five types of specific handball playing actions were also studied: 1) jumps; 2) shots; 3) stops when preceded by high-intensity activities; 4) changes of direction and 5) one-on-one situations. This is in accordance to the methods of Bangsbo et al. (1991) and handball's specificities.

Heart Rate

Sixty HR recordings of thirty outfield players (twenty-seven wings, twenty-three backcourt players and ten pivots) were registered in five-second intervals using Polar Team System (Polar Electro Oy, Kempele, Finland) during ten official matches. Individual maximal HR (HR_{max}) was previously determined using the Yo-Yo intermittent endurance test – level 2 (Bangsbo, 1994). HR values were analyzed during the first and second halves. Team handball rules allow unlimited substitutions of players throughout the match. Therefore, it is unusual that one player plays the entire match time (Luig et al., 2008; Ronglan, Raastad, & Borgesen, 2006). Also, a one-minute time-out period is allowed for each team, in each half. Several other match contingencies involve the interruption of the match time (e.g. players' injuries and suspensions). Thus, HR during the match was analyzed i) as total HR (i.e., HR during total match time) aiming to globally characterize cardiovascular demands imposed by the handball match and ii) as effective HR (i.e., HR during effective match time), in order to describe match demands only during the time in which the player is on the playing court. In the first case, two-minute suspensions and the half-time break were excluded from total match time. Nevertheless, in both cases the time-outs were considered. For this purpose, the matches were filmed. Procedures regarding image collection were described above. The matches were held under neutral temperature (17-21°C) and humidity conditions (50-70%). For determination of total and effective time spent on each HR zone, only the values corresponding to the first and second halves were considered.

Fluid Loss and Intake

To determine sweat loss during the match, the players were weighted wearing dry shorts, immediately before and after the matches using a digital balance (Tanita Inner Scan digital – BC532). The players were allowed to drink water *ad libitum* during the matches, and water intake was recorded. Weight and fluid loss (absolute and relative to body mass) due to the match were calculated according to Andersson et al. (2008).

Statistical Analyses

Results are presented as means \pm standard deviation (*SD*) and range. Differences between HR and time-motion variables during the two halves were assessed by Student's paired t-test. Differences between high and low-intensity activities and total and effective HR were determined by Student's unpaired t-test. Statistical Package for the Social Sciences (SPSS Inc, version 17.0) was used for all analyses. Statistical significance was set at $p \leq 0.05$.

Results

Activity Profile during the Game

The number of occurrences and the total time spent and distance covered (absolute and relative values) for each locomotor and intensity category performed by the handball players during the match are presented in Table 1. The duration and distance covered in each locomotor category are also shown.

TABLE 1 – Activity profile of team handball players during a match. *Freq* – frequency; *FR* – fast running; *Back* – backwards movement; *SideM* – sideways medium-intensity movement; *SideH* – sideways high-intensity movement; * $p \leq 0.02$ significantly different from high-intensity movements. Values are means \pm *SD*.

	Locomotor categories							Intensity categories		
	Standin g	Walkin g	Joggin g	FR	Sprint	SideM	SideH	Back	High	Low
Freq (<i>N</i>)	268 \pm 86.5	261 \pm 64.8	98 \pm 28.7	30 \pm 17.5	22 \pm 10.0	75 \pm 39.8	20 \pm 20.3	67 \pm 38.0	73 \pm 31.8	752 \pm 189.7*
Freq (%)	32.1 \pm 5.85	31.5 \pm 3.57	12.0 \pm 3.46	3.4 \pm 1.95	2.6 \pm 0.87	8.9 \pm 3.87	2.3 \pm 1.86	7.6 \pm 3.24	8.8 \pm 2.76	91.2 \pm 2.76*
Duration (s)	7.0 \pm 8.26	5.9 \pm 4.75	3.9 \pm 1.96	3.1 \pm 1.25	2.8 \pm 1.08	3.1 \pm 1.66	2.3 \pm 1.01	2.9 \pm 1.35		
Distance (m)		7.7 \pm 6.20	10.3 \pm 5.21	16.7 \pm 6.68	18.0 \pm 6.91	4.2 \pm 2.26	9.0 \pm 3.89	2.9 \pm 1.35		
Fraction of total time (%)	43.0 \pm 9.27	35.0 \pm 6.94	8.8 \pm 3.14	2.2 \pm 1.21	0.4 \pm 0.31	5.2 \pm 3.20	1.1 \pm 0.95	4.5 \pm 2.33	3.6 \pm 1.61	96.7 \pm 1.61*
Fraction of total distance (%)		45.9 \pm 7.16	23.2 \pm 6.14	11.5 \pm 5.74	2.4 \pm 2.02	6.5 \pm 3.86	4.3 \pm 4.04	6.1 \pm 3.05	18.3 \pm 7.70	81.7 \pm 7.70*
Total time (s)	1886 \pm 422.6	1533 \pm 327.1	382 \pm 126.2	95 \pm 52.8	17 \pm 13.7	228 \pm 137.3	47 \pm 42.6	197 \pm 106.2	159 \pm 73.2	4225 \pm 269.0
Total distance covered (m)		2002 \pm 427.2	1014 \pm 334.8	508 \pm 281.6	107 \pm 87.3	287 \pm 173.3	183 \pm 164.9	268 \pm 144.8	798 \pm 370.1	3571 \pm 658.2

Match duration was 73 ± 4.5 minutes and total distance covered during the handball match was 4370 ± 702.0 m. The most frequent highly demanding playing actions of the game were stops and changes of direction (Table 2).

TABLE 3 – Game actions and time-outs frequency during the match and in each half. Values are means \pm SD. * $p \leq 0.05$ significantly different from the first half of the match.

Game actions	First half	Second half	Total
Jumps	7.1 \pm 3.91	6.7 \pm 3.22	13.8 \pm 6.14
Throws	3.2 \pm 2.49	3.5 \pm 2.30	6.7 \pm 3.95
Stops	17.0 \pm 7.58	14.4 \pm 6.13*	31.4 \pm 12.44
Changes of direction	16.4 \pm 7.45	14.2 \pm 6.30*	30.6 \pm 12.38
One-on-one situations	11.1 \pm 8.28	9.2 \pm 8.20*	20.3 \pm 15.70
Time-outs	First half	Second half	Total
	4.7 \pm 1.52	8.0 \pm 2.81*	12.7 \pm 3.80

The activity profile in both halves of the match is presented in Figure 1.

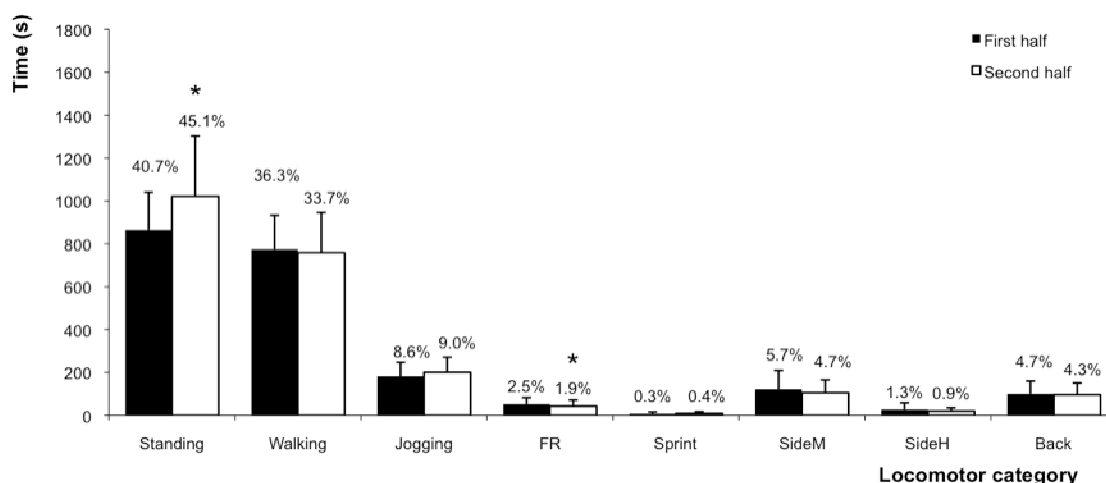

FIGURE 1 – Absolute and relative time spent in each locomotor category in the first and second halves of the match. Values are means \pm SD. FR – fast running; Back – backwards movement; SideM – sideways medium-intensity movement; SideH – sideways high-intensity movement; * $p \leq 0.05$ significantly different from the first half of the match.

The time spent in high-intensity movements during the match decreased in the second half (4.1 ± 2.10 vs. $3.2 \pm 1.55\%$; $p = 0.04$), as well as the frequency of stops, changes of direction and one-on-one situations (Table 2). Furthermore, an increase in the frequency of time-outs was also observed in the second half (Table 2).

Match Heart Rate Analysis

The peak HR during the match was 185 ± 9.6 bpm and the effective mean HR was 157 ± 18.0 bpm ($82 \pm 9.3\%$ of HR_{max}) whereas the total mean HR was 10% lower (139 ± 31.9 bpm; $72 \pm 16.7\%$ of HR_{max} ; $p = 0.00$; Figure 2). During the second half, effective (160 ± 16.7 vs. 153 ± 18.7 bpm; $p = 0.00$) and total (141 ± 33.0 vs. 136 ± 30.4 bpm; $p = 0.00$) mean HR decreased comparing to the first half.

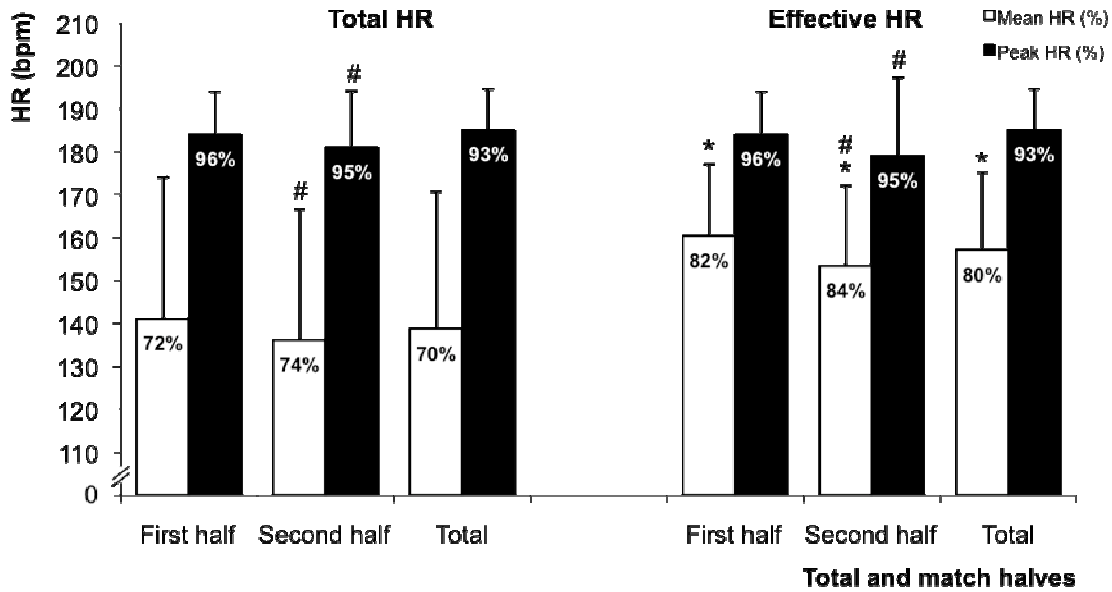

FIGURE 2 – Average and maximal total and effective heart rate (HR) during the first and second halves and total match time. Data are presented as means \pm SD. Absolute and relative to individual maximal HR values are shown. bpm – beats per minute; * $p = 0.00$ significantly different from total HR; # $p = 0.00$ significantly different from the first half of the match.

Fluid Loss and Intake

The body weight loss during the matches was 0.8 ± 0.52 (0.0-1.4) kg corresponding to 0.9 ± 0.34 (0.0–1.3) % of the body mass and the fluid intake was 1.19 ± 0.298 (0.6-1.5) L. Thus, the fluid loss during the matches was 2.1 ± 0.35 (1.4-2.9) L corresponding to 2.3 ± 0.36 (1.9-3.1) % of the body mass.

Conclusions

Main results showed that handball is a high demanding intermittent sport despite the amount of time spent in low intensity activities, since high-intensity actions and moments are required throughout the game.

This study was supported by the Portuguese Foundation for Science and Technology (SFRH/BD/38148/2007).

spovoas@docentes.ismai.pt

METABOLIC PROFILE OF ELITE TEAM HANDBALL

¹Susana Cristina de Araújo PÓVOAS, ²José Manuel da Costa SOARES,
²António Natal Campos REBELO

¹CIDESD, Maia Institute of Higher Education, Maia, Portugal; ²CIFID, Faculty of Sport, University of Porto, Porto, Portugal

Summary

This study analyzes the effect of an elite male handball game on blood and plasma metabolic markers. The anaerobic glycolytic metabolism seems to be moderately taxed during the match, although individual blood lactate values suggest that the glycolic rate is high in certain moments. Fat metabolism seems to be strongly activated, particularly during 2nd half of the game, which may likely contribute to explain the reduced exercise intensity towards the end of the match.

Keywords: *Team handball; metabolic markers; elite male players.*

Introduction

Team handball is played professionally at a high competitive level in many European countries. Despite the amount of time spent in low-intensity activities, handball is considered a complex high demanding intermittent sport, since it involves frequent body contact and several other high-intensity actions to overcome opponents. Nonetheless, unlike other team sports, scientific knowledge regarding elite team handball physiological strain is scarce. Moreover, the description of metabolic demands imposed by the game is limit to blood lactate values (Delamarche et al., 1987; Michalsik, 2004).

Methods

A friendly match was held between two elite teams in order to analyse the effect of the match on plasma and blood biochemical markers. Even though usual proceedings and rules of official matches were assured, time-motion and heart rate (HR) analyses were conducted during this friendly match aiming to establish match intensity. Time-motion and HR data were also registered during ten official matches. Venous blood samples for measuring plasma free fatty acids (FFA), glucose, glycerol and uric acid (UA) concentrations were obtained at rest and at the end of each half of the match. Capillary blood samples for measuring blood lactate concentrations were collected at rest, at each 5-min period during the match and at the end of each half. Players were advised to maintain their normal nutritional habits and coaches were asked to continue the usual training schedule. Evaluations were carried out in the middle of competitive period where the training schedule included 6–7 training sessions per week.

Subjects

Biochemical, HR and time-motion data were obtained from eighteen outfield elite male players (25.2±3.25 yrs; 186.4±7.59 cm; 86.9±8.01 kg and 9.5±2.56 % fat mass) during the friendly match. The players' HR and activity profile were also analysed during ten official matches. Participants had at least five years of experience in the top Portuguese handball competition. All subjects were previously informed about the aims of the study, the risks associated with the experiment and familiarized with all testing protocols and procedures before delivered written consent to participate. The experimental protocol was approved by the local ethics committee and followed the Declaration of Helsinki of the World Medical Association for research with humans.

Match time-motion analysis

The players were video-filmed during the entire matches in order to establish game motion pattern according to methods previously used (Bangsbo, Norregaard, & Thorso, 1991). Players' displacements were coded into eight locomotor categories defined accordingly to Bangsbo et al. (1991) and considering handball's specific movements. The locomotor categories were defined as follows: 1) standing still, 2) walking, 3) jogging, 4) fast running, 5) sprinting, 6) backwards movement, 7) sideways medium-intensity movement and 8) sideways high-intensity movement. The mean velocity of each category was determined by detailed analysis of match images using the lines of the playing court as reference. The distance covered in each category equaled the product of the total time and the mean speed for that activity (Krustrup, Mohr, & Bangsbo, 2002). The total distance covered during a match was calculated as the sum of the distances for each type of activity. High-intensity activities corresponded to the sum of categories 4, 5 and 8 and low-intensity activities were the sum of categories 1, 2, 3, 6 and 7.

Heart rate

Players' HR during the matches was registered in 5-s intervals using Polar Team System (Polar Electro Oy, Kempele, Finland). Individual maximal HR (HR_{max}) was previously determined using the Yo-Yo endurance intermittent test – level 2 (Yo-Yo IE 2) (Bangsbo, 1994). HR values were analysed during the 1st and 2nd halves. Team handball rules allow unlimited player substitutions throughout the match. Therefore, it is unusual that one player plays the entire match time (Luig et al., 2008; Ronglan, Raastad, & Borgesen, 2006). Also, a one min time-out period is allowed for each team, in each half. Several other match contingencies involve the interruption of the match time (e.g. players' injuries and suspensions). Thus, HR during the match was analysed i) as total HR (i.e., HR during the total match time), aiming to globally characterize cardiovascular demands imposed by the handball match and ii) as effective HR (i.e., HR during effective match time), in order to describe match demands only during the time in which the player is on the playing court. In the first case, 2-min suspensions and the half-time break were excluded from total match time. Nevertheless, in both cases the time-outs were considered. The match was held under neutral temperature (17-22°C) and humidity conditions (50-70%). For determination of total and effective time spent on each HR zone, only the values corresponding to the 1st and 2nd halves were considered.

Fluid loss and intake

To determine sweat loss during the matches, the players were weighted wearing dry shorts, immediately before and after the match using a digital balance (Tanita Inner Scan digital – BC532). The players were allowed to drink water *ad libitum* during the matches, and water intake was recorded. Weight and fluid loss (absolute and relative to body mass) due to the match were calculated according to Andersson et al. (2008).

Statistics

Changes in blood metabolites parameters before, during and after the match were determined by analysis of variance (ANOVA) with repeated measures. When a significant interaction was detected, data were subsequently analyzed using a Bonferroni post hoc test. Differences between high and low-intensity activities, total and effective HR and between HR and activity profile of the friendly and the official matches were determined by Student's unpaired t-test. Statistical Package for the Social Sciences (SPSS Inc, version 17.0) was used for all analyses. Statistical significance was set at $p \leq 0.05$.

Results

Intensity and fluid loss and intake during the matches

Time-motion and HR results showed no significant differences in the total distance covered and the percentage of high-intensity activity performed during the friendly and the official matches analysed.

The average body weight loss during the matches was 0.8 ± 0.43 (0.0-1.6) kg corresponding to 0.9 ± 0.46 (0.0–1.6) % of the body mass and the fluid intake was 1.28 ± 0.306 (0.7-1.6) L. Thus, the average fluid loss during the matches was 2.1 ± 0.47 (1.5-2.9) L corresponding to 2.3 ± 0.38 (1.9-3.2) % of the body mass.

Biochemical markers

Average and peak blood lactate were 3.6 ± 2.12 and 7.5 ± 1.17 mmol.l⁻¹, respectively (Table. 1). Blood lactate concentrations showed a significant increase during both halves when compared to pre-match values. Plasma glucose and UA values remained stable during the game. After the 1st half, plasma FFA and glycerol showed the highest increases ($P \leq 0.05$), particularly after the 2nd half ($P \leq 0.05$), in which there was also a significant ($P < 0.05$) increase comparing to the 1st half.

Table 1. Blood lactate and plasma glucose, free fatty acids (FFA), glycerol and uric acid (UA) concentrations before, during and after the match. Blood lactate data were collected during the 1st and 2nd halves, while values concerning the remaining parameters refer to measures taken at the end of both halves.

Biochemical parameters	Before	1st half	%Δ	2nd half	%Δ
Glucose (mM)	5.9±0.77 (4.8–7.4)	7.5±1.08* (6.2–9.7)	30±23.0* (0–82)	6.8±0.85* (5.2–8.2)	18±17.4* (-21–40)
FFA (mM)	0.2±0.04 (0.1–0.3)	0.5±0.20* (0.3–0.9)	169±101.3* (50–350)	0.9±0.41*# (0.4–1.6)	343±209.8* (100–700)
Glycerol (mM)	0.03±0.012 (0.01–0.05)	0.11±0.025* (0.07–0.15)	327±207.5* (75–900)	0.17±0.059*# (0.12–0.29)	567±352.4* (200–1600)
UA (nM)	0.30±0.055 (0.20–0.40)	0.40±0.105* (0.28–0.63)	40±47.7* (-18-155)	0.40±0.082* (0.24–0.53)	38±31.2* (-8–90)
Blood lactate (mM)	1.1±0.11 (0.9-1.4)	4.2±2.26* (1.6–8.6)		3.1±1.84* (1.3–8.4)	

Presented data are mean \pm SD, range and percentage of variation (%Δ) vs pre-match values. * $P \leq 0.05$ 1st or 2nd halves vs pre-match evaluations; # $P \leq 0.04$ 2nd vs 1st halves.

Conclusions

Data of the present study suggest that the anaerobic glycolytic metabolism is moderately taxed during the handball game, although individual blood lactate values suggest that the glycolic rate is high in certain moments in the game. Fat metabolism seems to be strongly activated, particularly during the 2nd half of the game, which may likely contribute to explain the reduced exercise intensity towards the end of the match.

This study was supported by the Portuguese Foundation for Science and Technology (SFRH/BD/38148/2007).

spovoas@docentes.ismai.pt

THE RELATION BETWEEN PERCENTAGE OF BODY FAT AND MEASURES OF RUNNING SPEED, JUMP POWER AND VO_{2max} CONSUMPTION IN SLOVENIAN JUNIOR ELITE HANDBALL PLAYERS

Marko ŠIBILA, Marta BON, Uroš MOHORIC, Primož PORI

University of Ljubljana, Faculty of Sport, Ljubljana, Slovenia

Summary

We tried to find out correlations between percentage of body fat and measures of running speed, jump power and VO_{2max} consumption indicator. The subjects were 90 elite slovenian junior handball players. Descriptive statistics were computed. Correlations were established by Pearson correlation coefficients. We may conclude that all motoric parameters and VO_{2max} consumption are in a negative relationship with the percentage of body fat tissue.

Key Words: elite handball, body fat, motoric.

Introduction

The physical part of a team handball game consists of a combination of intense, intermittent activities such as running, sprinting, jumping as well as regular struggles between players – holding and pushing (Jensen, Johansen, & Liwendahl, 1999). Morphological characteristics of the body and motor abilities certainly have a great influence on an outstanding performance in handball (Jensen, Johansen & Larsson, 1999; Šibila, & Pori, 2009, Mohamed, et al., 2009). That is particularly typical of top handball, where the advantages of players with a suitable morphological and motor structure are evident (Rannou, Prioux, Zouhal, Gratas-Delamarche, & Delamarche, 2001). Recent research studies dealing with the morphological profile of a top-level handball player highlighted that they are characterised by a prevailing mesomorphic somatotype with a touch of ectomorphy, that is, with a pronounced longitudinal dimensionality of the skeleton (Šibila, & Pori, 2009). In terms of handball players' motor structure, the most prominent are the explosive and elastic power of the legs, arms and shoulder girdle, sprint speed and specific aerobic endurance (Šibila, 1989; Jensen, Johansen, & Liwendahl, 1999). Due to the above, measurements of morphological physical characteristics and motor abilities are used in the identification and further selection of talented individuals (Šibila, 1996). Apparently, in sport games performance also correlates with some other abilities, characteristics and qualities (Falk, Lidor, Lander, & Lang, 2004). In Slovenia, the aim of the systematic measurements of handball players at the national level is to objectivise the assessment of an individual player's talent and thus influence their inclusion in national teams at various development levels (Šibila, 2009). In small countries it is particularly important that the monitoring of players' development is systematically supported and underpinned by scientific findings (Bloomfield, Ackland, & Elliot, 1994). In addition, the acquired results are used to help plan the training of the measured individuals (Šibila, 2009). Namely, the selection of talented players is a continuous process of identification of those who, at different development levels, meet the requirements for joining handball teams (Mohamed, et al., 2009). Yet it should be considered that the complexity of identifying talent relates to both a genetic predisposition (Bouchard, Malina, & Pérusse, 1997) and the capacity to improve through intensive training (Ericsson, Krampe, & Tesch-Römer, 1993; Reilly, Williams, Nevill, & Franks, 2000). To acquire relevant data from the discussed areas, a special measurement system was developed in Slovenia for young handball players of the national team aged from 17 to 21 years (Šibila, 2009). The applied measurement procedures covered the majority of abilities and characteristics relevant to handball players' efficiency.

Alongside regular monitoring of this characteristics and abilities by the young slovenian elite handball players we recongnized that a share of body fat increase. That's way we tried to found out correlations between percentage of body fat and measures of running speed, jump power and VO_{2max} consumption indicator.

Methods

Sample

The subjects were 90 elite slovenian junior players which participate in regular testing of junior national teams – they belong to three different generations (born 1988/89, 1990/91 and 1992/93).The measurements were carried out in 2009 and 2010. At the time of measurement, the study subjects were 17.43±1.57 years old on average. Their average body height was 185.5±6.38 cm and body mass 83.0±10.67 kg.

Variables

The assessment of subject's subcutaneous fat value (percentage of body fat) was calculated from 9 skin fold measures based on the standard anthropometric battery with 24 dimensions (Duquet, & Hebbelinck,1977). The assessment of the explosive and elastic power of the legs was made using the Opto Jump device; the study subjects performed two different jumps: a squat jump (SJ) and a counter movement jump (CMJ). The ability to generate sprint speed was assessed using sprint times over 5, 10 and 20 m with a standing start (T5m, T10m and T20m) and a flying start (FT5m, FT10m and FT20m). Running endurance was assessed using the 30-15IFT test (Buchheit, 2005a; Buchheit, 2005b). This is an intermittent fitness test (with interruptions) performed on a handball court – 30 s of running and 15 s of rest. The subjects were running at a pace dictated by a sound signal. The running speed increased with each repetition and the runners persevered until exhaustion or so long as they were capable of running the specific distance foreseen in the interval. The obtained result enables the approximate maximum use of oxygen to be calculated using the following formula: VO_{2max}(ml/min/kg) = 28.3 – 2.15 * G – 0.741 * A – 0.0357 * P + 0.0586 * A * V + 1.03 * V, where: G is gender (1 = male, 2 = female), A is age, P is weight and V is the final velocity recorded in the test. All measurements were conducted by the same people, using the same measurement technology.

Table1: Sample of variables

Test	Measured capacity	Measuring unit
% of body fat	Amount of body fat	%
5-m sprint – standing start	Sprint speed	seconds
10-m sprint – standing start	Sprint speed	seconds
20-m sprint – standing start	Sprint speed	seconds
5-m sprint – flying start	Sprint speed	seconds
10-m sprint – flying start	Sprint speed	seconds
20-m sprint – flying start	Sprint speed	seconds
VO _{2max}	Maximal O ₂ consumption	ml/min/kg
Squat Jump	Explosive power of leg	cm
Counter Movement Jump	Elastic power of leg	cm

Data analysis

The data were analysed using the statistical package SPSS 16.0. Basic parameters of the distribution of variables were calculated (mean, standard deviation, minimum and maximum values, kurtosis, skewness and Kolmogorov-Smirnov test of variables). Pearson Correlation

Coefficient) was used to test the degree of correlation among the variables. A probability level of 0.01 or less was taken to indicate significance.

Results

Table 2 presents the basic statistical characteristics of body height, body mas, % of body fat and selected motor parameters. The table shows average values, standard deviations, minimum and maximum values, kurtosis, skewness and significance of the Kolmogorov-Smirnov test.

Table 2: Basic statistical characteristics of all parameters

Parameter	\bar{x}	S	min	max	kurt	skew	pK-S
Age	17.43	1.57	15.0	20.0			
BH	187.25	5.93	166.4	202.9	.376	.312	.827
BM	83.0	10.67	60.2	109.1	-.332	.192	.935
%FM	12.93	4.49	6.3	27.3	1.128	1.072	.158
T _{5m}	1.13	.07	.97	1.31	-.262	.438	.245
T _{10m}	1.94	.11	1.71	2.20	-.318	.247	.284
T _{20m}	3.18	.14	2.91	3.54	.344	-.171	.585
TF _{5m}	.69	.04	.60	.78	-.117	.176	.435
TF _{10m}	1.36	.09	1.18	1.59	-.378	.409	.361
TF _{20m}	2.52	.11	2.29	2.81	.263	.544	.573
VO _{2max}	50.0	2.54	42.86	57.72	.639	-.147	.476
SJ	33.82	5.3	23.2	47.4	-.263	.376	.857
CMJ	36.16	5.46	24.14	52.1	-.188	.192	.977

Legend: \bar{x} - average values; s - standard deviations; min – minimum values; max - maximum values; kurt – kurtosis; skew – skewness; pK-S – significance of the Kolmogorov-Smirnov test; : BH - Body height; BM - Body mass; %FM - Amount of body fat; T_{5m} - 5-m sprint – standing start; T_{10m} - 10-m sprint – standing start; T_{20m} - 20-m sprint – standing start; TF_{5m} - 5-m sprint – flying start; TF_{10m} - 10-m sprint – flying start; TF_{20m} - 20-m sprint – flying start; VO_{2max} - Maximal O₂ consumption; SJ - Squat Jump; CMJ - Counter Movement Jump.

The data reveal that all measured parameters are normally distributed.

Table 3 show the results of Pearson Correlation coefficients based on which we established whether there were any statistically significant relationships among percent of body fat value and results in motoric tests. In the table we placed also the coefficients that show the correlation between motor variables themselves.

Table 3: Values of Pearson Correlation coefficients among all variables

	%FM	T _{5m}	T _{10m}	T _{20m}	TF _{5m}	TF _{10m}	TF _{20m}	VO _{2max}	CJ	CMJ
%FM	1.000	-,312**	-,328**	-,474**	-,423**	-,297**	-,499**	-,542**	-,304**	-,320**
T _{5m}	-,312**	1.000	,729	,845	,400	,333	,558	,319	,456	,389
T _{10m}	-,328**	,729	1.000	,797	,716	,813	,697	,435	,624	,547
T _{20m}	-,474**	,845	,797	1.000	,639	,547	,857	,382	,587	,553
TF _{5m}	-,423**	,400	,716	,639	1.000	,797	,770	,330	,537	,534
TF _{10m}	-,297**	,333	,813	,547	,797	1.000	,722	,421	,607	,548
TF _{20m}	-,499**	,558	,697	,857	,770	,722	1.000	,388	,591	,610
VO _{2max}	-,542**	,319	,435	,382	,330	,421	,388	1.000	,340	,239
CJ	-,304**	,456	,624	,587	,537	,607	,591	,340	1.000	,727
CMJ	-,320**	,389	,547	,553	,534	,548	,610	,239	,727	1.000

Discussion and Conclusions

We may conclude from our study that all motoric parameters and VO_{2max} consumption are in a negative relationship with the percentage of body fat tissue. In the literature we can find similar findings - excessive fat mass may negatively affect an athlete's flexibility, power, speed, agility, and aerobic capacity (Houtkooper, Mullins, Going, Brown, & Lohman, 2001; Klossner, 2007). Some researchers revealed (Castro-Pinero, et al., 2010), weight status (and body fat level) could have a significant influence on sport performance. Obese children, according to that research, gained lower scores in sprint performance than their leaner counterparts. Obesity is a consequence of poor nutritional choices and limited physical activity. Presumably, some players from our research could have too much body fat because of combination - unhealthy eating patterns and somehow the lack of appropriate physical training.

Another important aspect to be taken into consideration is that obese children get tired very easily and quickly during physical exercise (training) and they need twice as much energy than their slim peers (Moya, 2008). Moreover, overweight children are more likely to be injured in sport as compared with their non-overweight counterparts (Mc Hugh, 2010), due to biomechanical inefficiency or other factors [Jonnalagadda, Skinner, & Moore, 2004]. That is why early observation of children, longitudinal monitoring and relatively quick prevention of weight problems are necessary.

Optimal competitive body weight and share of body fat varies between athletes, sports, and positions (Gibson, 2009). So also in handball, there are differences in the proportion of body fat by the first division players at different playing positions (Šibila, & Pori, 2009). It's also the fact that overweight in athletes appear especially in sports, in which body size and body mass are important, e.g. football, sumo, weight-lifting, and in which body components can affect physical performance, beyond body size and advancement level. Those factors have been identified as predictors of performance and selection in a number of sports (Gibson, 2009). Similarly, of course, also applies to handball where weight is extremely important success factor especially at the pivot position. But the negative relationship between increased body fat percent and achievements in the important motor tests for players from our sample suggests that reducing body fat is necessary for progress in the sports performance in handball. Following our findings coaches should instruct players to reduce redundant body fat tissue by appropriate diet and training. It can be assumed that this would positive affect the results in motor skills that are important for successful playing handball.

Marko.Sibila@fsp.uni-lj.si

POSTURAL STABILITY OF ELITE WOMEN'S HANDBALL PLAYERS

Martin TUMA, Frantisek ZAHALKA, Tomas MALY

Charles University, Faculty of Physical Education and Sports, Prague, Czech Republic

Summary:

The study shows postural stability in the top level women's handball players during a two-legged stance with or without visual control. All experiments were performed on a testing device Footscan (RScan International, Belgium). Exclusion of the visual inspection in bipedal standing positions shows a minimal deterioration trend of the monitored parameters.

Keywords: Handball, postural stability, elite players, sport injuries

Introduction:

The aim of this study is to describe the level of postural stability within a group of top level women's handball players. Normal balance and balance during sports activities require proper neuromuscular control, which is a unique integration of inputs from the periphery into the central nervous system and back (Vrbanic et al. 2006). This occurs unconsciously and skeletal muscles surrounding a joint are automatically activated in response to sensory stimuli (Matthews, 1982). If there is insufficient condition of postural control, the risk of injuries is dramatically increasing. The aim of the study is to show the need of good postural stability for the top level women's handball players during a two-legged stance with or without visual control, as well as the suitability of good postural stability in more complicated stances. A one-legged stance should also meet the conditions of symmetrical realization for both left and right leg. According to Peterka (2002), healthy adults on a firm base of support and in well-lit conditions will rely on 70 percent somatosensory, 20 percent vestibular, and 10 percent visual input to maintain postural support. As the environment changes, the individual can reweight his or her relative dependence on these inputs (Horak, 2006). Vision has a dominant role in coding and processing of all other sensory information (Paulus et al., 1984). To maintain an upright standing position sight is not necessary, one can stand in the dark, but visual deprivation during standing with eyes closed, however, decreases the stability of upright standing (Schieppati et al, 1999). It also leads to a reduced quality of performance of dynamic postural tasks (Buchanan, Horak, 1999). It is dynamic postural tasks arising from various game situations that are very important for stabilisation of the body and its subsequent activation for other gaming activities. The importance lies both in terms of sports performance and efficiency, and especially in terms of health, where the inability to stabilize the body during significant dynamic changes caused by movement increases the risk of uncontrolled falling and thereby increases the risk of injury. Both in static positions and dynamic changes of body position vision is largely involved in maintaining upright balance and physical equilibrium and is of great importance for balancing, estimating the speed of objects and body parts, as well as the timing of psychomotor reactions (Juodžbaliene and Muckus 2006). A healthy nervous system automatically evaluates how the body is oriented in space, depending on the context and upon the intended action. A person is able to orient his body perpendicular to the mat until the mat begins to tilt, then he orients his body according to sense of gravity. In the dark a healthy person is able to determine vertical axis of gravity to an accuracy of 0.5° (Horak, 2006). Postural control requires numerous cognitive resources. The more difficult the postural task, the more cognitive processing is required. (Horak, 2006). Response times and quality of the performance of cognitive tasks deteriorate as the demands for postural tasks increase (Teasdale et al., 2001). Performing postural tasks is aggravated by simultaneously

performing a cognitive task, because postural control and other cognitive processes share cognitive resources (Camicioli et al., 1997). The most important biomechanical constraint on balance is the size and quality of the base of support: the feet. Any limitation of the size, muscle tone, strength, range of motion, perception of pain, or motion control affects the balance (Tinetti et al., 1988). Stimulation of the visual system (Bronstein, 1986, Dijkstra et al., 1994), the vestibular system (Johansson and Magnusson, 1991) and the proprioceptive system (Jeka et al., 1997) causes a change in postural stability represented by a body sway.

Method:

The subjects are members of the Czech national women’s handball team (n= 14, age = 24±3,5 years, height = 175,97 cm, BMI = 23,41±2,34 kg/cm²). All experiments were performed on a testing device Footscan (RScan International, Belgium), size 0.5 m x 0.4 m, sensing field 4100 sensors with a resolution set at 0.1 N/cm². Frame rate was set at 33 Hz. The subjects were tested using a 6-test Kapteyn (1983) for 30 seconds: (1) wide standing position with eyes open (further as WPS-EO), (2) wide standing position with eyes closed (further as WPS-EC), (3) narrow standing position with eyes open (further as NSP-EO), (4) narrow standing position with eyes closed (further as NSP-EC), (5) standing position on the right lower extremity „flamingo test“ (further as FLA-R), (6) standing position on the left lower extremity „flamingo test“ (further as FLA-L). The testing period for one-legged stances was 60 seconds. Evaluation criteria were the following: the change in the front to back direction (X) and the change in the left-right direction (Y). Figure 1 shows an example of a stabilographic test representing the changes of Centre of pressure (COP) in front to back and left-right directions.

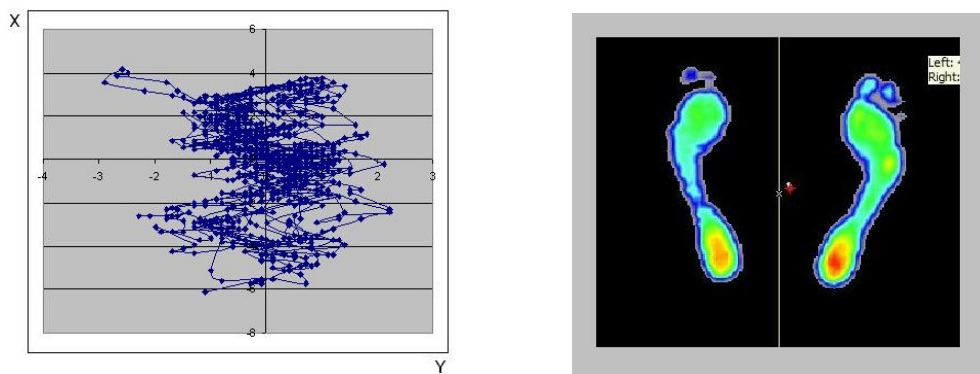

Figure 1 a stabilographic test representing the changes of Centre of pressure (COP) and an imprint of the feet.

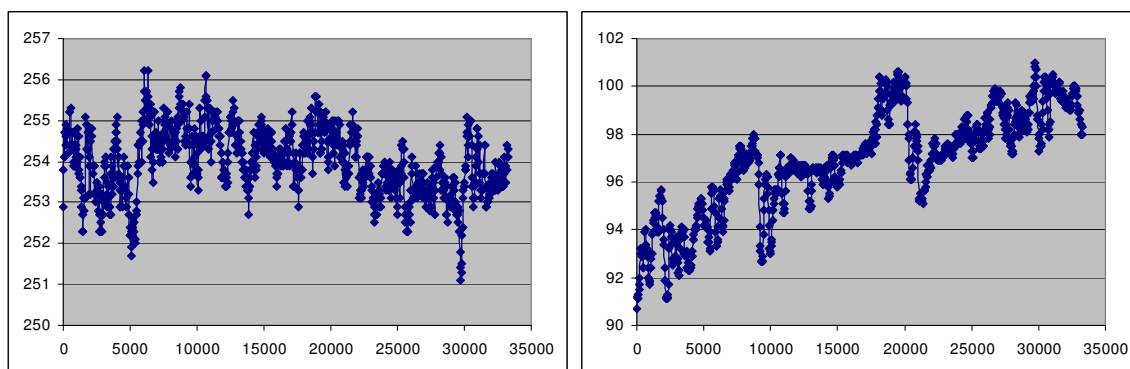

Figure 2 the changes of Centre of pressure (COP) in front to back (X) and left-right (Y) directions.

Figure 2 is a graphical representation of the COP changes during the test in different directions. The horizontal axis is the position of the COP indicated in mm, on the vertical axis is time of the test in ms.

Another parameter evaluated was the total swaying track during the test (total travelled way - TTW). To assess the dominance of swaying for each direction, left-right or front to back, the results were evaluated using the frequency of changes of COP from the centre line. The latter was determined by calculating the average values of coordinates of all changes in different directions. After that each sway was evaluated on the frequency of deviations from this average value. The ratio of the frequency of X values greater than 1 implies a sway to the right, the ratio of the frequency of X less than 1 implies a sway to the left, respectively forward and backward for the axis Y.

Figure 3 plots the frequency of sways; the central vertical axis of the graph represents the calculated centre line with the number of sways. The vertical axis shows the distance from the centre in increments of 0.1 mm. Each point shows the number of occurrences of COP in the particular distance. The graph shows that approximately 1 mm from the centre the frequency is only in the tens of units, and with increasing distance the frequency is similar.

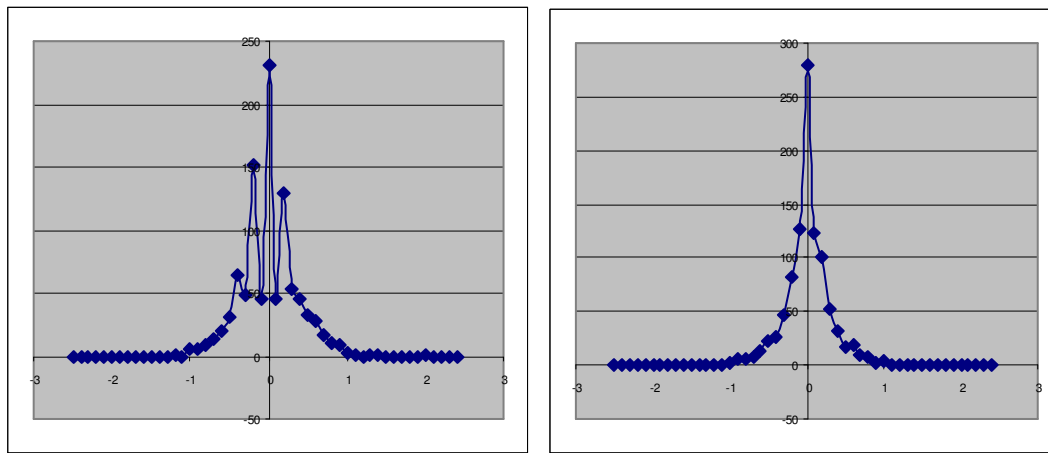

Figure 3: A chart of COP swaying frequency in left-right and front to back directions.

The values represented in the graphs can be expressed numerically so that the peak of the curve is 231 and means the number of displacements from the average value in the range of 0.1 mm, which is the sensitivity of measuring equipment. All values left of the central vertical graphs represent the sum of 394 deflections in this direction. To the right there are 373 deflections and the mutual ratio of 0.9 can mean that during the test a person swayed more to the left. The distribution frequency for the front to back direction is very symmetrical; the total number of deflections in the average was 280. There are 372 forward deflections and 346 backward deflections. The mutual ratio of 1.1 shows that the monitored person swayed more forward.

Results:

The first evaluation test is wide standing position with eyes open. This is the most commonly used test of postural stability. The main evaluation criteria were the deflection in the left-right direction (in this evaluation marked as deflection in the X axes) and deflection in the front to back direction (deflection in the Y axis) and the total travelled way of COP forces during the test (TTW - Total travelled way). More specifically, the group has reached a deflection in the X axes = 6.81 ± 3.19 mm, in the Y axis = 12.53 ± 8.45 mm, TTW = 270.67 ± 74.44 mm.

From the wide standing position with eyes closed we had expected deterioration in postural stability, which could be reflected in the increase of numbers of deflections in both axes and the overall increase of TTW. This is exactly what happened: a deflection in the X axes = 8.33 ± 7.52 mm, in the Y axis = 16.29 ± 11.28 mm, TTW = 298.74 ± 105.99 mm. From the results it can be concluded that the removal of visual inspection has relatively little effect on reducing

postural stability of the monitored group. The high standard deviation is mainly caused by high results showed by one player.

Another group of tests was based on a narrowing of the support base. These tests showed deflections in the X axes = 11.32 ± 10.06 mm, in the Y axis = 13.82 ± 6.29 mm, TTW = 216.47 ± 53.74 mm. Narrow standing position with eyes closed caused deterioration in the observed parameters: deflections in the X axes = 14.73 ± 12.33 mm, in the Y axis = 17.45 ± 10.10 mm, TTW = $277.15 \pm 105, 40$ mm. Here we can also state that the difference in deflections in open and closed eyes positions were not at that high, it is 3 to 4 mm, TTW shows significantly higher difference of 61 mm. The measured velocity of deflections was very similar in all the tests: wide standing position with eyes open 6.91 ± 1.93 mm / s, eyes closed 8.96 ± 3.18 mm / s, narrow standing position with eyes open $6,49 \pm 1,61$ mm/s, eyes closed $8,31 \pm 3,16$ mm/s.

	Test	Visual control	Mean	Std. Deviation	Test	Visual control	Mean	Std. Deviation
DELTAx (mm)	WSP	YES	6,81	3,19	Velocity (mm/s)	YES	6,91	1,93
		NO	8,33	7,52		NO	8,96	3,18
	NSP	YES	11,32	10,06		YES	6,49	1,61
		NO	14,73	12,33		NO	8,31	3,16
DELTAy (mm)	WSP	YES	12,53	8,45	TTW (mm)	YES	270,67	74,44
		NO	16,29	11,28		NO	298,74	105,99
	NSP	YES	13,82	6,29		YES	216,47	53,74
		NO	17,45	10,10		NO	277,15	105,40

Legend: WSP – wide standing position; NSP – narrow standing position

Table 1: Basic parameters while standing on both legs

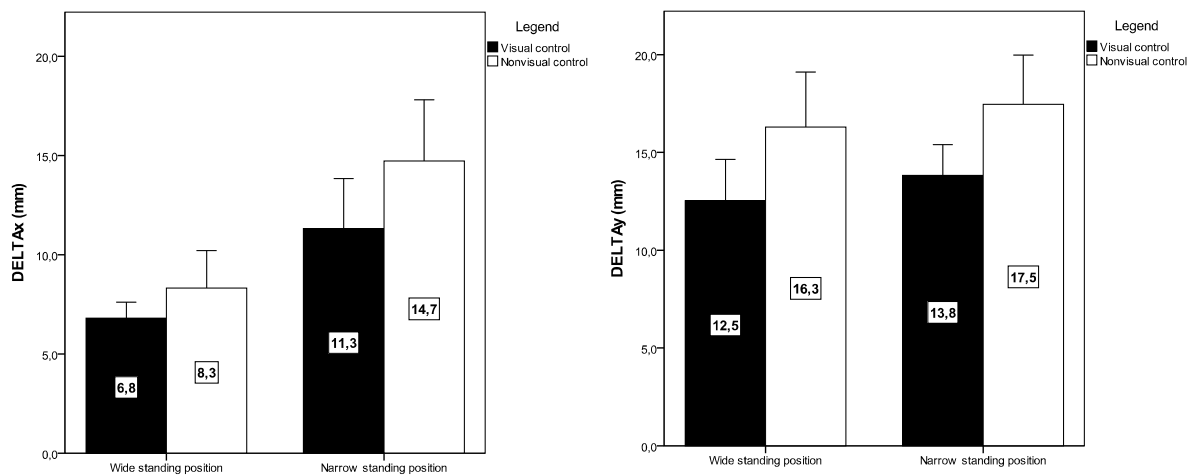

Figure 3: Graphical comparison of deflections in the front to back and left-right direction in both types of standing positions.

Another evaluation criterion was the frequency of deflection in the left-right or front to back directions. The frequency ratio of deflections in the left-right direction at wide standing position with eyes open 1.01 and with eyes closed 0.99. It could be possible to assume that with open eyes the players swayed more to the right, and with closed eyes more to the left. Deflection, however, are so small, that it can be concluded that in both types of tests were the deflections in the left-right direction balanced. Similar results were obtained while analysing the deflections in the front to back direction.

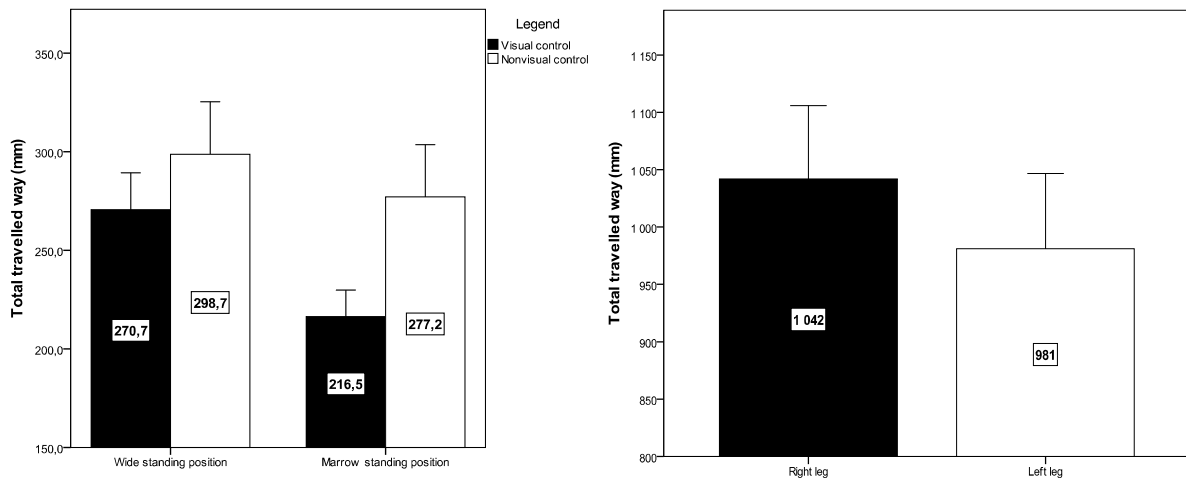

Figure 4: Graphical comparison of TTW for all types of standing positions.

The frequency ratio of deflections in the left-right direction at wide standing position with eyes open 0.98 and with eyes closed 1.02. Again it would be possible to assume that the players would sway more to the front with the eyes open and back with the eyes closed. Yet again, the ratios can be considered too close to each other and too balanced to make such a conclusion. The same can be observed at the test of narrow standing position with eyes open and closed. The values of the ratio of the frequency of deflection were 1.03 to 0.98 and 1.01 to 1.02 respectively.

A standing position on one lower extremity is a separate type of test. This is the hardest type of standing position, which runs the longest time. Compared to bipedal tests lasting 30 seconds, here is the length of the test 60 seconds. The main purpose of this test is to assess the symmetry of standing on an isolated lower extremity; our hypothesis is that postural stability on the left and right lower extremity is comparable.

Parametres	Leg	Mean	Std. Deviation	Std. Error Mean
DELTAx (mm)	Right	21,87	3,99	1,00
	Left	21,84	5,77	1,44
DELTAy (mm)	Right	37,84	17,63	4,41
	Left	35,51	12,04	3,01
Velocity (mm/s)	Right	31,26	7,67	1,92
	Left	29,43	7,87	1,97
TTW (mm)	Right	1042,00	255,56	63,89
	Left	981,01	262,29	65,57

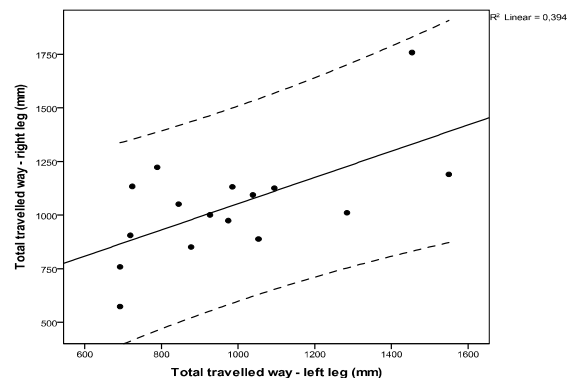

Table 2: Basic parameters of standing on one lower extremity and a graphical representation of interdependence.

The table shows that within all investigated parameters very comparable results were achieved. The difference in the deflections in the right-left direction is on average equal in both groups standing on the right and left lower extremity, deflections in the front to back direction are different in the absolute value by just 2.3 mm (difference 6.5%).

TTW while standing on the left lower extremity is shorter by 60.9 mm (difference 5.8%) than while standing on the right lower extremity. While standing on the right lower extremity the ratio of deflection indicates a slight swaying to the right and forward, while standing on the left lower extremity the ratio is very balanced.

Discussion and conclusion:

Exclusion of the visual inspection in bipedal standing positions shows a minimal deterioration trend of the monitored parameters. This result is inconsistent with some studies (Wolsley, Sakellari, Bronstein 1996; Bronstein, Buckwell, 1997; Redfern, Yardley, and Bronstein, 2001), which state that information from the fixed visual environment decreases postural deflections. Narrowing of the support base in different test positions for the entire group resulted in almost all the measurements in the increase of postural deflections and extension of the total COP path. This result is entirely consistent with the widespread assertion that postural control becomes more difficult with narrowing of the support base. The athletic population, particularly at the top level, shows a much milder inclination to that trend. Likewise, at the exclusion of the visual inspection the general population demonstrated a lower level of body oscillation while standing with eyes open (Dichgans et al., 1976). This supports the fact that the degree of change of the quality of the standing position depends on other factors such as the width of standing, the type of support base and the availability of other sensory perceptions (Vařeka, 2002). When testing the stability of standing positions on one lower extremity a significant correlation was found between the length of the Total travelled way (TTW) between the right and left lower extremity ($r = 0.68$, $p < 0.01$). In practice this means that a player who achieves excellent performance on one of the lower extremities is likely performance excellently on the other lower extremity. This may not apply in the case of an old knee or ankle injury. Top level sport places higher demands on the postural stability regardless of the width of the support base and the visual inspection, both in static and dynamic form. Equally high expectations are placed on the symmetry of stabilization of an isolated lower extremity, both in terms of implementation of static positions and dynamic position changes in terms of gaming performance and health aspects of the body.

Project was supported by GACR P407/11/P784 and MSM 0021620864.

tuma@ftvs.cuni.cz

SOMATIC CHARACTERISTICS OF SELECTED YOUTH FEMALE PLAYERS BY CZECH TRAINING CENTRES

Martin TUMA & Petra VOZOBULOVA

Faculty of Physical Education and Sport, Charles University, Prague, Czech Republic

Summary

The aim of this research is to determine the somatotype of 41 young female handball players – members of training centers. We used Heath – Carter method (1967) to calculate somatotypes. Czech youth female players are endomorphic mesomorphs in average in all playing positions. The results are comparable with those obtained at W17 ECH in Brno 2011.

Keywords: *Anthropometry, Handball, Female, Somatotype*

Introduction

Handball is demanding for both aerobic and anaerobic capacity as well as the strength and high level of mastery of movement stereotypes. The important factor is also the anthropometric profile of handball players. The relationship between anthropometric characteristics and demands of athletic performance may be more acute in female than in male players in view of the development of the game in the last few years (Hasan et al., 2007).

There were several researches which were focused on somatotype profile of female handball players. Štěpnička (1972) measured 78 female players (age 22.2). Average values of their height was 165.6 (± 4.92) cm, body mass was 61.99 (± 6.00) kg and somatotype was 4.10 – 4.25 – 2.28. The same values are also shown in the work of Hájková (1993). Bayios et al. (2006) measured 222 Greece female handball players and determined average somatotype 4.20 – 4.70 – 1.80. Hasan (2007) was focused on anthropometric parameters of 60 Asian top female players (age 22.2 ± 2.9 , body height 171 ± 6.8 cm and body mass 64.6 ± 7.7 kg).

The aim of this research is to determine the somatotype of Czech youth female handball players which have been selected for special training centers.

Methods

The research sample consisted of 41 players (age 17.36 ± 1.09) of 3 women training centres in Czech Republic. The players were divided into 5 groups depends on their playing position: Goalkeepers (n = 2, age 17.44 ± 2.04), Wings (n = 10, age 17.18 ± 0.93), Centre backs (n = 6, age 17.87 ± 1.14), Backs (n = 19, age 17.47 ± 1.09), Pivots (n = 4, age 17.07 ± 1.45).

We used software Somatotype – Calculation and Analysis (by Sweat Technologies) to calculate somatotypes of research sample using Heath – Carter method (1967).

We measured the following anthropometric parameters:

- *Body height* – measured by stadiometer
- *Body mass*
- Parameters of transversal dimension: *biepicondylar breadth of the humerus* and *biepicondylar breadth of the femur* – measured by thoracometer
- Parameters of body volume (circumferential) dimension: *upper arm circumference*, *calf circumference* – measured by fiberglass tape measure
- Skinfold thickness: *triceps skinfold*, *subscapular skinfold*, *supraspinal skinfold* and *medial calf skinfold* – measured by KALIPER BEST II K-501

The definitions of 13 categories are based on the areas of the 2-D somatochart (Carter and Heath, 1990):

- *Central*: no component differs by more than one unit from the other two.
- *Balanced endomorph*: endomorphy is dominant and mesomorphy and ectomorphy are equal (or do not differ by more than one-half unit).
- *Mesomorphic endomorph*: endomorphy is dominant and mesomorphy is greater than ectomorphy.
- *Mesomorph-endomorph*: endomorphy and mesomorphy are equal (or do not differ by more than one-half unit), and ectomorphy is smaller.
- *Endomorphic mesomorph*: mesomorphy is dominant and endomorphy is greater than ectomorphy.
- *Balanced mesomorph*: mesomorphy is dominant and endomorphy and ectomorphy are equal (or do not differ by more than one-half unit).
- *Ectomorphic mesomorph*: mesomorphy is dominant and ectomorphy is greater than endomorphy.
- *Mesomorph-ectomorph*: mesomorphy and ectomorphy are equal (or do not differ by more than one-half unit), and endomorphy is smaller.
- *Mesomorphic ectomorph*: ectomorphy is dominant and mesomorphy is greater than endomorphy.
- *Balanced ectomorph*: ectomorphy is dominant and endomorphy and mesomorphy are equal (or do not differ by more than one-half unit).
- *Endomorphic ectomorph*: ectomorphy is dominant and endomorphy is greater than mesomorphy.
- *Endomorph-ectomorph*: endomorphy and ectomorphy are equal (or do not differ by more than one-half unit), and mesomorphy is lower.
- *Ectomorphic endomorph*: endomorphy is dominant and ectomorphy is greater than mesomorphy.

Results

Body height

The average body height of players was 170.6 cm (\pm 6.39). Highest value was found in the group of Backs and it was 172.1 cm (\pm 6.0). The pivot group also exceeded the average value of the research sample and average body height of this group was 171.8 cm (\pm 1.89). The average body height of Goalkeepers was 170.5 cm (\pm 6.36) and of Wings was 166.6 cm (\pm 7.44). The lowest average of body height had the group of Centres and it was 165.9 cm (\pm 4.76).

Body mass

The average body mass of players was 67.4 kg (\pm 8.66). Highest value was found in the group of Backs and it was 69.5 kg (\pm 8.90). The average body weight of Goalkeepers was 68.9 kg (\pm 4.38) and of Pivots was 67.8 kg (\pm 8.06) and of Centres was 67.4 kg (\pm 8.98). The lowest average of body mass had the group of Wings and it was 61.98 kg (\pm 7.30).

Tab.1: Summary of measurements – Averages of groups

	Body Height	Body Mass	Endo	Meso	Ecto	Categorization
Goalkeepers	170.5	68.9	3.1	4.5	1.9	endomorph mesomorph
Backs	172.1	69.5	3.4	4.2	2.4	endomorph mesomorph
Centre Backs	165.8	67.4	3.9	5.7	1.4	endomorph mesomorph
Wings	166.6	61.98	3.1	4.2	2.3	endomorph mesomorph
Pivots	171.8	67.8	2.9	4.3	2.3	endomorph mesomorph
X	170.6	67.4	3.4	4.4	2.2	endomorph mesomorph
SD	6.39	8.66	1.00	1.12	0.97	

Somatotype

The average value of endomorphic component of players equaled 3.4 (± 1.00). The highest endomorphic value (3.9) was recorded in Centre Backs, the lowest (2.9) in Pivots. The average value of mesomorphic component of players equaled 4.4 (± 1.12). The highest mesomorphic value (5.7) was recorded in Centre Backs, the lowest (4.2) in Backs and Wings. The average value of ectomorphic component of players equaled 2.2 (± 0.97). The highest ectomorphic value (2.4) was recorded in Backs, the lowest (1.4) in Centre Backs. The typical characterization of somatotype in Czech female handball training centers is endomorphic mesomorph (41 % out of whole sample). Representation in each somatotype category is shown in Table 2.

Tab.2: The distribution of somatotype categories in the research sample.

	GK	B	CB	W	P	ALL
Central	-	3	-	2	1	6
Mesomorph – endomorph	-	3	2	1	1	7
Endomorphic mesomorph	2	6	4	4	1	17
Balanced mesomorph	-	3	-	1	-	4
Ectomorphic mesomorph	-	2	-	1	1	4
Mesomorph – ectomorph	-	1	-	-	-	1
Mesomorphic ectomorph	-	1	-	-	-	1
Balanced ectomorph	-	-	-	1	-	1
	2	19	6	10	4	n = 41

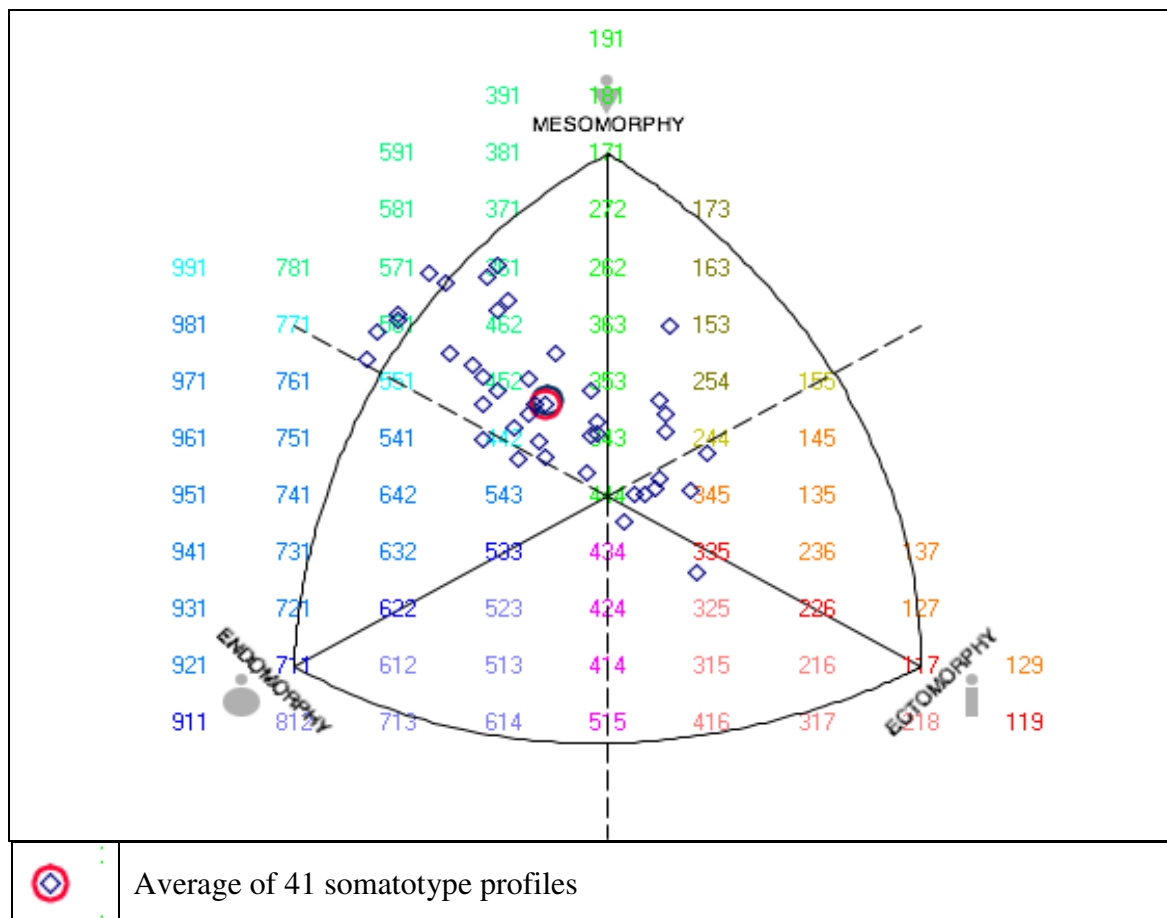

Fig. 1: Somatotypes of 41 female handball players of Czech training centres.

Conclusions

The main observations in this study were that all players' positions are homogenous in anthropometric characteristics and also in somatotype. We found a different category of somatotype than Štěpnička (1972) and Bayios (2006) which determine it like mesomorph-endomorph. Czech youth players are *endomorph-mesomorphs* in average and we didn't find any significant differences between choosing groups.

Identified data of anthropometric characteristics are comparable to those measured at the U17 European Championship 2011 in Brno and Zlín (these data will be published by Urban on EHF website during autumn 2011). Somatotype differs significantly only in endomorphic components. Czech players have a higher proportion of these components than the players of European U17 national teams which was characterized in average as balanced mesomorphs.

tuma@ftvs.cuni.cz

POSITION-RELATED CHANGES IN ANTHROPOMETRIC PROFILES OF TOP MALE HANDBALL PLAYERS: 1980 AND 2010

František URBAN¹, Róbert KANDRÁČ², František TÁBORSKÝ³

¹ High School Ostrovskeho, Sport Management, Kosice (SVK) / member of Union of University Handball Teacher

² University of Presov, Faculty of Sport, Presov, Slovakia (SVK)

³ Charles University, Faculty of Physical Education and Sport, Prague (CZE) / chairman of Methods Commission EHF

Summary:

The purpose of the study was to determine the effect of developmental trends on selected anthropometric parameters in handball. The results showed that differences were most profound in Bs. Overall, minimal differences in body height, arm span, biacromial breadths and highest values of circumferential dimensions accentuate the need of taller body constitution with well-developed skeleton and musculature.

Keywords: *anthropometry, body composition, male handball players*

INTRODUCTION

Proportionality of somatic parameters primarily determines differences between individual playing positions. Human body consists of several fractions that affect body composition, quality of movement and player's game skills. Due to the fact that tasks and functions are position-specific, we may assume that besides motor abilities and skills, adequate body composition is beneficial in terms of effective execution of position-related functions. The ratio between body mass, percent subcutaneous fat, longitudinal, transversal and circumferential measures of individual body segments are closely related to player's body height. Longitudinal dimensions including body height represent one of the elementary determinants underlying appropriate assignment of the player to a playing position. Generally, body height is an important element required for effective execution of defensive and offensive actions (ball handling, shooting, blocking, stealing the ball). *Body height is an elementary morphological parameter, which is the basis for the evaluation of the dynamics of human movement* (Riegerová, Přidalová, Ulbrichová, 2006). Developmental changes in handball resulted in tempo game, which is strenuous in terms of both physiological functioning and sustained physical load. Over the last 10 years the speed of game actions has increased significantly. The number of attacks has increased, their duration has decreased, the transition from defense to offense has intensified and more teams have started using fast shooting combinations following a goalkeeper throw. The explosiveness of game skills (speed and strength without loss of execution accuracy) is an underlying factor of all game situations (mainly one on one). We assume that adequate body composition: strong skeleton and well-developed musculature, relatively low percent subcutaneous fat, adequate ratio of body mass to body height is beneficial for maintaining high level of performance in contemporary handball.

METHODS

The purpose of the cross-sectional study was to determine the effect of developmental trends on selected anthropometric parameters in handball.

Samples

1st sample 2010¹ (Urban, F., Kandrác, R., Táborský, F.): a total of 256 players from 16 countries participating in 8th Men's 20 European Handball Championships 2010 in Bratislava, Slovakia (ECh Men's 20).

2nd sample 1980² (Štěpnička, J., Chytráčková, J., Táborský, F.): a total of 122 U19 players from 8 countries participating in the Družba Cup in ČSSR (Czechoslovak Socialist Republic).

The players were divided into position-specific groups: GKs - goalkeepers, Ws - wings, CBs - center backs, Bs - backs and PVs - pivots (see Table 1).

Tab. 1 Basic characteristics of samples

Sample	x	Age (n)					Playing positions (n)					Summary
		20	19	18	17	16	GKs	Ws	CBs	Bs	PVs	
2010 ¹	19.61	65	82	8	1	-	38	71	45	63	39	256
1980 ²	18.34	-	64	39	15	4	19	32	19	34	18	122

Variables

We measured the following anthropometric parameters:

- parameters of longitudinal dimension: body height and arm span
- body mass
- parameters of transversal dimension: biepicondylar breadth of the humerus and biepicondylar breadth of the femur.
- parameters of body volume (circumferential) dimension: upper arm circumference (biceps) and calf circumference (calf). The circumferential measures were taken in flexed condition of the individual muscles.

Methods of data procession

The collected data were processed using basic statistical characteristics: *x* - arithmetic mean, *s* - standard deviation. The differences between samples were determined using t-test for independent samples.

RESULTS AND DISCUSSION

Body height: the lowest body height average was found in Ws: ¹183.77 ±4.63 cm and ²182.48 ±5.35 cm, when the body height averages differed by 1.29 cm in favor of the 2010 sample. Generally, back players are among the tallest players in handball. This was confirmed in both samples as Bs were found to be tallest: ¹193.49 ±4.29 cm and ²191.43 ±4.50 cm. The difference between samples in body height average was statistically significant (*p*<.05) and equaled 2.06 cm. The greatest difference in body height was registered in PVs, when statistically significant difference (*p*<.01) equaled 4.49 cm. The lowest difference, which equaled 0.77 cm, was observed in CBs.

Tab. 2 Position-Related Differences in Body Height (cm)

Samples	GKs	Ws	CBs	Bs	PVs	Summary
2010 ¹	190.36±5.21	183.77±4.63	186.49±4.64	193.49±4.29	192.69±5.42	188.98±6.23
1980 ²	188.65±5.37	182.48±5.35	185.72±5.29	191.43±4.50	188.20±5.06	187.28±6.05
<i>Diff.</i>	1.71¹	1.29¹	0.77¹	2.06¹	4.49¹	1.70¹
<i>t</i>	1.14	1.23	0.57	2.19*	2.92**	

Legend: *diff.* - difference; *t* - t-value; * *p*<.05; ** *p*<.01

Higher body height average was found in players who participated in the ECh Men's 20 championship. The standard deviations indicate relative homogeneity of data in both samples as the differences between body height averages were minimal in all playing positions. On the other hand, the differences between playing positions are evident. Táborský (2007) concluded that it is advantageous to compose a team not only exclusively of tall players, but also some players that are relatively "smaller".

Body mass: the lowest body mass average was recorded in Ws: $^{1}79.65 \pm 5.08$ kg and $^{2}78.15 \pm 8.28$ kg. Regarding the playing functions, the highest body mass average was found in PVs from 2010: 93.93 ± 8.63 kg. Similarly to body height, the difference between both samples on the measure of body mass was greatest in PVs and equaled 10.41 kg. The differences in all playing positions favored 2010 players. Overall, the difference between both samples equaled 4.64 kg and was found to be higher in 2010 players. There were statistically significant differences ($p < .01$) in PVs, GKs and Bs. The differences in CBs and PVs on the measure of body mass were minimal. Higher values of standard deviations indicate relative heterogeneity.

Tab. 3 Position-Related Differences in Body Mass (kg)

<i>Samples</i>	<i>GKs</i>	<i>Ws</i>	<i>CBs</i>	<i>Bs</i>	<i>PVs</i>	<i>Summary</i>
2010¹	89.28±9.29	79.65±5.08	82.74±6.91	91.60±7.14	93.93±8.63	86.74±9.15
1980²	81.16±5.67	78.15±8.28	81.86±6.28	85.61±5.93	83.52±5.87	82.10±7.12
Diff.	8.11¹	1.50¹	0.88¹	5.99¹	10.41¹	4.64¹
t	4.18**	0.93	0.47	4.13**	5.21**	

Legend: diff. – difference; t – t-value; * $p < .05$; ** $p < .01$

Arm span: the Bs in both samples were found to have the highest average of arm span: $^{1}196.19 \pm 6.69$ cm and $^{2}198.05 \pm 7.02$ cm. The ratio of arm span to body height was largest in Bs as well and equaled $^{1}2.70$ cm and $^{2}6.62$ cm. The lowest arm span average was registered in Ws. The arm span average favored 1980 players: 1.60 cm. The differences between average values of arm span and body height was positive in both samples and all playing positions. Overall, the players from 1980 dominated on the measure of arm span.

Difference between arm span and body height:

2010¹: GKs: 1.75 cm; Ws: 1.23cm; CBs: 1.71 cm; Bs: 2.70 cm; PVs: 2.31 cm.

1980²: GKs: 3.92cm; Ws: 5.22 cm; CBs: 4.46 cm; Bs: 6.62 cm; PVs: 4.60 cm.

Tab. 4 Position-Related Differences in Arm Span (cm)

<i>Samples</i>	<i>GKs</i>	<i>Ws</i>	<i>CBs</i>	<i>Bs</i>	<i>PVs</i>	<i>Summary</i>
2010¹	192.11±5.97	185.00±7.04	188.20±6.77	196.19±6.69	195.00±7.31	190.90±8.18
1980²	192.57±6.75	187.70±7.03	190.18±7.22	198.05±7.02	192.80±8.17	192.50±8.10
Diff.	0.46²	2.70²	1.98²	1.86²	2.20¹	1.60²
t	0.26	0.00009	1.03	1.27	0.99	

Legend: diff. – difference; t – t-value; * $p < .05$; ** $p < .01$

The comparison indicated considerable difference, when the values of the 2010 sample were considerably lower compared to their counterparts from 1980. The relation between arm span and body height belongs among the beneficial somatic parameters in handball (Urban, 2010), when absolute and relative values of body height and arm span are advantageous irrespective of the playing position (Štěpnička, 1972) especially when *blocking, overcoming the block, covering specific area and reception of high and inaccurate passes.*

Biepicondylar breadths: when evaluating measures of transversal dimension, we found minimal differences between average values in all playing positions and samples as well. The average values of humerus breadth ranged from 7.22 cm (Ws¹) to 7.77 cm (Bs²). The greatest difference, which was statistically significant ($p<.05$), was registered between Ws: 0.24 cm and GKs: 0.23 cm. Statistically significant difference on the measure of humerus breadth was registered in Bs as well. The average value of femur breadth ranged from 10.33 cm (CBs¹, Ws²) to 10.64 cm (GKs²). The greatest difference, which was statistically significant ($p<.05$), was found between Bs: 0.27 cm. Overall, it may be concluded that players from 1980 demonstrated higher values of transversal measures, when the difference in humerus equaled 0.17 cm and femur 0.18 cm.

Tab. 5 Position-Related Differences in Biepicondylar Breadths (cm)

	Humerus				Femur			
	2010 ¹	1980 ²	Diff.	t	2010 ¹	1980 ²	Diff.	t
GKs	7.42±0.36	7.65±0.25	0.23²	2.75*	10.43±0.61	10.64±0.50	0.21²	1.28
Ws	7.22±0.31	7.46±0.41	0.24²	2.90*	10.36±0.58	10.33±0.48	0.03¹	0.25
CBs	7.45±0.30	7.60±0.29	0.15²	1.82	10.33±0.65	10.58±0.29	0.25²	2.09
Bs	7.57±0.33	7.77±0.35	0.20²	2.76**	10.48±0.58	10.75±0.32	0.27²	2.92*
PVs	7.60±0.34	7.58±0.31	0.02¹	0.20	10.52±0.74	10.56±0.42	0.04²	0.21
∑	7.43±0.36	7.60±0.35	0.17²		10.42±0.63	10.60±0.43	0.18²	

Legend: diff. – difference; t – t-value; * $p<.05$; ** $p<.01$

With regard to skeleton and articular strength, the statistical characteristics related to transversal measures indicate well-developed skeleton in both samples on all playing positions. As the gracile skeleton is less resistant to physical load (Grasgruber, Cacek, 2008), well-developed skeleton represents one of the necessary prediction parameters for handball players regardless of the playing position due to high frequency of contact situations.

Circumferential dimensions: contrary to transversal measures, the differences in circumferential measures were greater relative to playing position and sample. The differences between individual playing functions in biceps circumference ranged from 2.10 cm (Ws) - 3.82 cm (Bs) favoring the 2010 sample. The overall difference equaled 3.13 cm. Statistically significant differences ($p<.01$) were registered in all playing positions, when the most considerable difference was found in Bs.

Tab. 6 Position-Related Differences in Circumferential Measures (cm)

	Biceps				Calf			
	2010 ¹	1980 ²	Diff.	t	2010 ¹	1980 ²	Diff.	t
GKs	35.62±2.37	32.06±1.48	3.56¹	6.8**	39.75±2.58	38.02±2.27	1.73¹	2.44*
Ws	34.73±1.77	32.63±2.15	2.10¹	5.15**	38.47±2.14	38.06±1.57	0.41¹	1.08
CBs	36.16±2.33	33.11±2.07	3.05¹	4.53**	39.17±2.31	38.78±2.00	0.39¹	0.63
Bs	36.83±1.73	33.01±1.76	3.82¹	10.2**	40.50±2.14	39.40±1.80	1.10¹	2.52*
PVs	36.71±1.86	33.03±1.83	3.68¹	6.86**	41.03±2.28	38.81±2.30	2.22¹	3.34**
∑	35.93±2.15	32.80±1.90	3.13¹		39.67±2.45	38.60±1.98	1.07¹	

Legend: diff. – difference; t – t-value; * $p<.05$; ** $p<.01$

In the measure of calf circumference, the differences between playing positions ranged from 0.39 cm (CBs) to 2.22 cm (PVs). Players from 2010 demonstrated higher average values in all playing

positions, when the difference equaled 1.07 cm. Statistically significant differences were recorded in GKs, Bs and PVs.

Average values of circumferential measures in players on both samples indicate well-developed musculature, which is relative to the body constitution. The need of well-developed musculature in handball players has always been regarded a characteristic aspect, which increased the effectiveness of offensive and defensive playing skills.

GKs, Ws and Bs from 1980 were found to have higher values of epicondyle breadths. The biceps circumferences favored the players from 2010, when the differences on the measure of biceps circumference were statistically significant in all playing positions. Table 7 presents overview of anthropometric studies targeted at handball players.

Tab. 7 Overview of anthropometric studies

First author	n	Age	Parameter	x	Playing positions				
					GKs	Ws	CBs	Bs	PVs
Srhoj (2002) - 3 Top-quality teams	49	24.5	Body height	190.79	191.86	187.02	–	194.42	183.85
			Arm span	196.53	195.22	193.87	–	199.31	192.92
			Body mass	91.29	91.79	85.12	–	94.28	92.58
Acsinte (2007) - Meta-analysis			Body height	196.6	195.0	191.0	195.0	208.0	194.0
			Arm span	202.2	204.0	193.0	205.0	212.0	197.0
			Body mass	95.2	95.0	91.0	92.0	99.0	99.0
Hasan (2007) - 12 th Asian Games	71	25.3	Body height	183.2	186.5	184.2	183.7	185.8	–
			Body mass	82.2	80.8	81.6	84.7	88.5	–
Šibila (2009) - Slovenian national teams	78	25.1	Body height	184.44	187.91	183.68	–	191.11	188.60
			Body mass	89.56	89.99	83.80	–	91.57	92.29
Urban (2010) - Slovak national teams	49	18.3	Body height	186.9	185.3	181.5	–	189.2	190.1
			Arm span	187.9	185.9	181.9	–	190.3	192.4
			Body mass	86.6	88.6	77.9	–	85.9	110.6
Sporiš (2010) - Croatian elite handball players	92	26.4	Body height	192.1	195.2	183.9	–	196.7	196.3
			Arm span	–	199.9	185.8	–	197.8	199.0
			Body mass	96.0	100.0	89.1	–	96.7	107.6

CONCLUSIONS

The comparison of anthropometric profiles between individual playing functions showed considerable differences, which probably resulted from position-specific tasks required for their execution. The most statistically significant differences in anthropometric parameters were registered in players' profiles operating in B and PV position.

The statistical parameters of body height indicated inter-individual heterogeneity in both samples. Players from 2010 were taller by 1.7 cm, when statistical difference in body height was found in Bs and PVs. In body height, statistically significant differences were recorded in GKs, Bs and PVs, when contemporary players were 4.64 kg heavier. There were no statistically significant differences on the measure of arm span. It is interesting to note that players from 1980 had 1.6 longer arms compared to their counterparts from 2010. The difference between arm span and body height in 1980 players ranged from 3.92 cm to 6.62 cm, whereas in 2010 players the differences ranged from 1.23 cm to 2.7 cm.

The differences in transversal measures were statistically significant both in humerus and femur breadth in Bs from 1980. The evaluation of circumferential measures showed significant differences in biceps circumference in all playing positions in favor of the 2010 sample, when the difference in biceps circumference equaled *3.13 cm*. The same finding holds true for the measure of calf circumference, when statistically different were registered in GKs, Bs and PVs.

Over the last decade, handball has transformed into a faster, more aggressive game with increased number of contact situations. If a player wants to be effective in a particular game situation, he should be endowed with strong skeleton and well-developed musculature. These parameters are primarily relevant for players operating in wing, center back, back and pivot position.

From the aspect of playing functions, greatest difference was found in PVs, when PVs from 2010 were 4.49 cm taller and 10.41 heavier, had 2.2 cm greater arm span and higher values in biceps circumference: 3.68 cm and calf circumference: 2.22 cm. The least profound difference was recorded between CBs, when statistically significant differences were registered in biceps circumference.

feriz.urban@gmail.com

POSITION-RELATED CHANGES IN SOMATOTYPES OF TOP LEVEL MALE HANDBALL PLAYERS: 1980 AND 2010

František URBAN¹, Róbert KANDRÁČ², František TÁBORSKÝ³

¹ High School Ostrovskeho, Sport Management, Kosice (SVK) / member of Union of University Handball Teachers EHF

² University of Presov, Faculty of Sport, Presov, (SVK)

³ Charles University, Faculty of Physical Education and Sport, Prague (CZE) / chairman of Methods Commission EHF

Summary

The purpose of the cross-sectional study was to determine the effect of developmental trends on somatotypes in handball players. Lower endomorphy and ectomorphy with unchanged mesomorphy in wings, center backs, back and pivots demonstrate athletic physique: lower percent of subcutaneous fat, linearity and muscularity. The most profound change in somatotype category was found in goalkeepers and center backs.

Keywords: *somatometry, body composition, young handball players*

INTRODUCTION

Team sports games are characterized by heterogeneity and differences with regard to morphological composition between players in individual playing positions. In handball, there is close relation between somatotype and playing function. Therefore, it may be assumed that the composition of players' somatotypes in handball is not only relevant but also required.

Today, handball around the world is more dynamic and faster than ever before (Sevim, 2008). Over the last decade, handball rules have changed and developmental changes have resulted in tempo game, which has become more attractive for spectators through its more dynamic character. The changes to the rules have sped up and lengthened the time of effective use of the playing time. The game has become faster, more dynamic and demanding in terms of energy requirements (Urban, Kandrác, Lafko, 2010, Visnapuu, 2009, Táborský, 2011).

The developmental changes have brought about increased requirements related to the training process and transformation of training methods. On the other hand, handball has remained a contact and aggressive game requiring adequate somatic predispositions for maintaining high efficiency in contact situations. Acsinte, Alexandru, (2007) concluded that somatic predispositions are considerably beneficial irrespective of the playing function. Therefore, it may be assumed that somatotype strongly influences sports career of every handball player.

With regard to anthropometric parameters handball players demonstrate certain degree of both identical and specific somatotypes compared to athletes playing different sports. Taking into consideration the aforementioned aspects, we may assume that changes in players' somatotypes have occurred at the level of all playing functions.

METHODS

The purpose of the cross-sectional study was to determine the effect of developmental trends on somatotypes in handball players. To determine somatotypes, we used the modified method devised by Heath, Carter (1967). The method uses three-number rating representing the endomorphic, mesomorphic and ectomorphic somatotype component. The somatotypes of

players were plotted using somatopoints in a somatochart and were classified into categories by Carter, Heath (1990).

The data on somatic parameters were processed using basic mathematical and statistical characteristics: arithmetic mean: \bar{x} and standard deviation: s . The interposition differences were determined using the t-test for independent samples. The data required to determine somatotypes of handball players were processed using the program SOMATO.

Sample

1st sample 2010¹ (Urban, F., Kandráč, R., Táborský, F.): a total of 256 players from 16 countries participating in 8th Men's 20 European Handball Championships 2010 in Bratislava, Slovakia (ECh Men's 20).

2nd sample 1980² (Štěpnička, J., Chytráčková, J., Táborský, F.): a total of 122 U19 players from 8 countries participating in the Družba Cup in ČSSR (Czechoslovak Socialist Republic).

The players were divided into position-specific groups: GKs - goalkeepers, Ws - wings, CBs - center backs, Bs - backs and PVs - pivots (see Table 1).

Tab. 1 Basic characteristics of samples

Samples	\bar{x}	Age (n)					Playing positions (n)					Summary
		20	19	18	17	16	GKs	Ws	CBs	Bs	PVs	
2010 ¹	19.61	65	82	8	1	-	38	71	45	63	39	256
1980 ²	18.34	-	64	39	15	4	19	32	19	34	18	122

RESULTS AND DISCUSSION

The endomorphy component is indicative of relative fatness or slenderness of an individual. This component indicates the amount of subcutaneous fat relative to one's body constitution (Carter, 1990) and is considered an important somatic parameter for handball players. Endomorphic types of players often have the potential for gaining muscle, however, they cannot lose weight easily (Grasgruber, Cacek, 2008). Therefore, the relation between endomorphy and mesomorphy is very important. Endomorphy and mesomorphy are most changeable via training. Adequate endomorphy values in handball players range from 1.0 to 2.5 and mesomorphy values range from 4.0 to 6.0 (Urban, Kandráč, Táborský, 2011). Ectomorphy is related to relative body length and is difficult to be affected by training. Therefore, it is relevant to predict player's body height using the body height of his/her parents. The recommended ectomorphy values range from 1.5 to 3.0 (Urban, Kandráč, Táborský, 2011).

Tab. 2 Position-Related Differences in Endomorphy

Samples	ENDOMORPHIC COMPONENT					Summary
	GKs	Ws	CBs	Bs	PVs	
2010 ¹	2.2±0.92	1.4±0.45	1.7±0.61	1.7±0.65	2.0±0.81	1.8±0.73
1980 ²	2.2±0.48	2.1±0.55	2.2±0.68	2.3±0.72	2.5±0.70	2.2±0.63
Diff.	0	0.7 ^l	0.5 ^l	0.6 ^l	0.5 ^l	0.4 ^l
t	0.05	2.22**	6.22**	4.13**	2.85**	

Legend: diff. – difference; t – t-value t; * $p < .05$; ** $p < .01$

Endomorphy: changes were recorded in all playing functions except GKs, when the difference between the average values ranged from 0.5 to 0.7 (see Table 2). The most

profound differences were found in CBs and Bs. During the game, CBs and Bs possess the ball most of the time. However, their playing function has changed as they perform more short sprints and change direction more frequently than before. Players in these playing positions come into contact with opponents more often placing higher demands on physical conditioning. We also recorded statistically significant differences in the endomorphic component in Ws and PVs. The differences may be attributed to the change in position-related functions due to contemporary trends in handball.

Tab. 3 Position-Related Differences in Mesomorphy

MESOMORPHIC COMPONENT						
<i>Samples</i>	GKs	Ws	CBs	Bs	PVs	Summary
2010¹	4.5±1.27	4.8±1.11	5.0±0.94	4.6±0.89	4.8±0.99	4.8±1.05
1980²	4.6±1.08	5.1±0.87	5.2±0.93	4.9±0.85	4.8±0.89	4.9±0.92
Diff.	0.1²	0.3²	0.2²	0.3²	0	0.1²
t	0.29	0.14	1.37	1.59	0.77	

Legend: diff. – difference; t – t-value t; * $p < .05$; ** $p < .01$

Mesomorphy: the difference in mesomorphy ranged from 0.1 to 0.3 in favor of GKs, Ws, CBs and Bs from 1980. The average values ranged from 4.5 to 5.2. The data showed that players demonstrated well-developed musculature relative to their body height. Minimal differences confirmed the fact that well-developed musculature is still one of the primary performance-determining factors. The game has become faster and the intensity of the game has increased. Consequently, the number of contact situations during the game has increased. We assume that it is the strong body build that plays an important role in 1:1 game situations.

Tab. 4 Position-Related Differences in Ectomorphy

ECTOMORPHIC COMPONENT						
<i>Samples</i>	GKs	Ws	CBs	Bs	PVs	Summary
2010¹	2.5±0.90	2.5±0.75	2.6±0.76	2.7±0.89	2.3±0.78	2.5±0.82
1980²	3.3±0.99	2.7±0.79	2.7±0.93	3.1±0.71	2.9±0.84	2.9±0.84
Diff.	0.8²	0.2²	0.1²	0.4²	0.5²	0.4²
t	3.00**²	2.58 *	1.22	2.24 *	0.44	

Legend: diff. – difference; t – t-value t; * $p < .05$; ** $p < .01$

Ectomorphy: the change in somatotype from the viewpoint of somatotype categorization in GKs showed that contemporary GKs (2010 sample) were categorized as balanced mesomorphs, which is indicative of more muscular, or robust body type (lower ectomorphy, unchanged endomorphy and mesomorphy). We assume that such somatotype is beneficial in terms of covering the shots of wing players, shots of pivots while falling or back players landing into the goal area. On the other hand, if the more robust somatotype is to be productive, then the ratio of body mass, percent subcutaneous fat and musculature has to be proportionate to one's body height. Ectomorphy indicates the body linearity and the proportionality of the size of the frontal part of body and the length of individual segments is an underlying morphological parameter in GKs.

The change in somatotype category was recorded in CBs as well. Contemporary Bs were categorized as ectomorphic mesomorphs. The primary function of Bs is to organize and create the game and the ability to complete the goal situations executing long-range shots from

difficult positions. In the offensive phase of the game, the Bs are confronted with opponent's defense and the middle of defense is characterized by robust and tall players. Therefore, relatively higher body height, well-developed skeleton and muscle mass are beneficial for back players.

Similarly to CBs, Ws demonstrated low values of endomorphy. The differentiation between these playing functions is, from the kinesiological aspect, not so different (speed, dynamics and movement coordination).

Tab. 5 Position-Related Differences in Somatotype Categorization

CATEGORIZATION						
	GKs	Ws	CBs	Bs	PVs	Summary
2010¹	balanced	ectomorphic	ectomorphic	ectomorphic	balanced	ectomorphic
	mesomorph	mesomorph	mesomorph	mesomorph	mesomorph	mesomorph
1980²	ectomorphic	ectomorphic	balanced	ectomorphic	balanced	ectomorphic
	mesomorph	mesomorph	mesomorph	mesomorph	mesomorph	mesomorph
Diff.	change	-	change	-	-	-

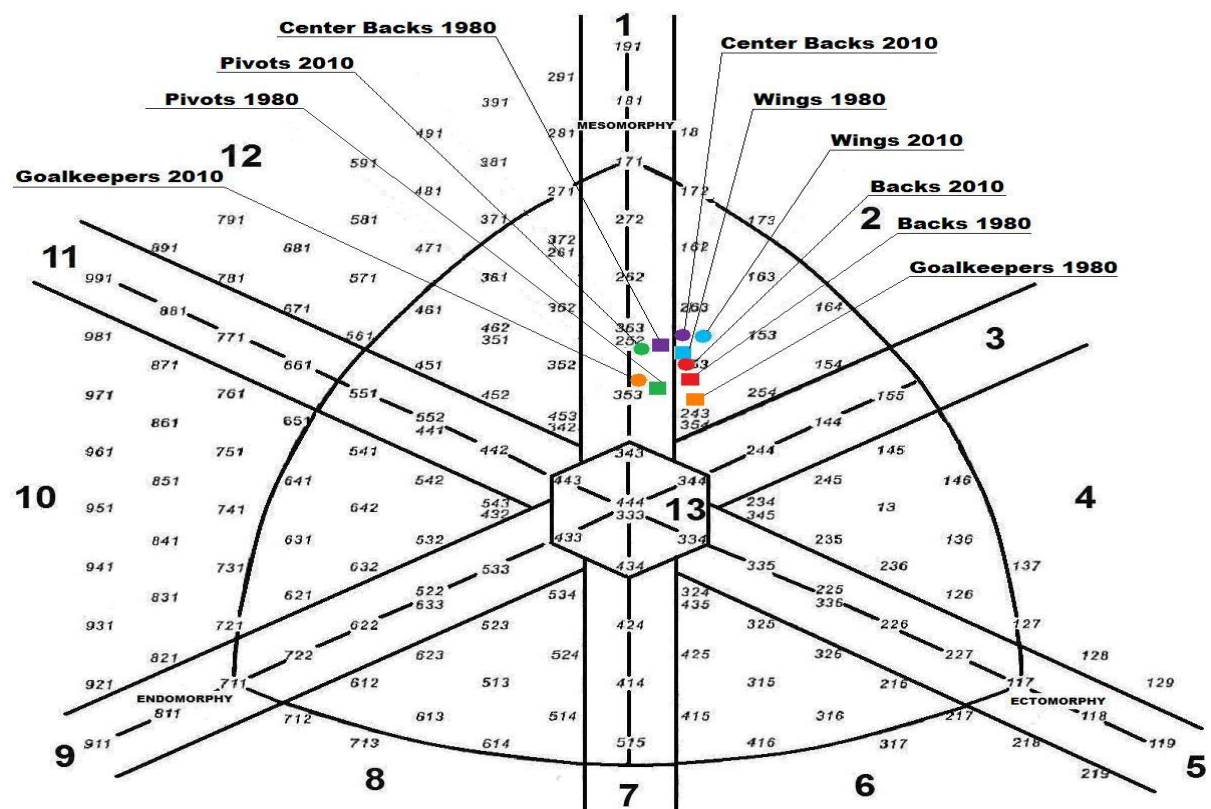

Fig. 1 Position-related somatotype categorization

Body size, shape, proportions, composition and the degree of maturity are somatic abilities that are either beneficial or counterproductive for player performance (Acșinte, Alexandru, 2007). Grasgruber, Cacek (2008) reported balanced somatotype in contemporary handball players: 2.5-5.0-3.0. This finding has been partially confirmed by other studies conducted in handball players. However, it should be noted that average value is not indicative enough of

the team composition. Therefore, it is important to assess and differentiate players from the aspect of individual playing functions.

Tab. 6 Somatotype - Overview the published studies

Studies	Samples	n	Age	Somatotype
Štěpnička (1972)	CSSR top level players	21	24.3	2.7 - 5.0 - 3.0
Present study ² (1980)	Druzba Juniors Cup	122	18.3	2.2 - 4.9 - 2.9
Marthur (1985)	Nigerian handball players	16	21.4	1.9 - 4.9 - 3.2
Šibila-Pori (2009)	Slovenian top level players	78	25.1	2.3 - 4.9 - 3.0
Urban (2010)	Slovakian junior players	49	18.3	2.0 - 4.8 - 2.3
Present study ¹ (2010)	ECh Men's 20	256	19.6	1.8 - 4.8 - 2.5

CONCLUSIONS

Regarding somatotypes, we found the following inter-position and inter-sample differences: With regard to individual somatotype components, greatest difference was recorded in endomorphy between Ws, CBs, Bs and PVs. Lower average endomorphy values of players from 2010 demonstrate lower percent subcutaneous fat, which is consistent with dynamic character of contemporary handball. There were minimal differences in mesomorphy ranging from 0.1 to 0.3, when higher value was found in 1980 players. This finding confirms the need of well-developed musculature regardless of the playing position as the character of handball as an aggressive and contact game has remained with intensification of contact game situations.

With regard to ectomorphy, higher values were registered in 1980 players, when the biggest difference was recorded in GKs, Ws and Bs.

Low values of ectomorphy show that contemporary players are less linear. Low values of endomorphy and minimal changes in mesomorphy accentuate musculature, which means that players have athletic and muscular physique.

Contemporary players in playing positions Ws, Bs, CBs and PVs are relatively more slender with lower amount of depot fat. This finding is consistent with the change in the character of the game and increased training demands necessary for achieving success in contemporary handball.

One of the primary factors that affected the character of handball over the last decade is changes to the rules of the game, which resulted in the tempo game. The developmental trends increased the performance-related demands, which led to changes in the training process. Training itself does not induce changes only motor functions but also players' somatotypes. Therefore, we assume that, as a consequence of the requirements of the game, differences in position-related somatotypes were recorded mainly due to developmental trends in handball and changes to the rules of the game.

feriz.urban@gmail.com

ANTHROPOMETRIC PROFILE IN FEMALE ELITE HANDBALL PLAYERS BY PLAYING POSITIONS

Helena VILA¹, Carmen MANCHADO², Arturo ABRALDES³, Pedro ALCARAZ¹,
Nuria RODRIGUEZ¹, Carmen FERRAGUT⁴

¹UCAM, Murcia; ²UA, Alicante; ³UM, Murcia; ⁴University of Alcalá de Henares, Madrid Spain.

Abstract

Female handball is a sport which has been enjoying a loud development in the last decade. The aim of this study was to identify possible differences in the anthropometric characteristics in terms of individual playing positions in female handball players. Statistical differences have been established in wings with the others specific playing positions, especially with pivot and backs.

Keywords: *Performance, somatotype, body composition.*

Introduction

The body composition of the athletes, has attracted the interest of the scientific community, which is evidenced by the great amount of papers that have been published describing the anthropometric profile of different sports (Ackland, Schreiner and Kerr, 1997; Bayios, Bergeles, Apostolidis, Noutsos and Koskoloul, 2006; Chaouachi, Brughelli, Levin, Boudhina, Cronin and Chamari, 2009; De Garay, Levine and Carter, 1974; Hasan, Reilly, Cable and Ramadan, 2007). Research published since the 1928 Olympic Games have shown correlations between different sports and physical characteristics as another factor to consider in the sport's success. It has been reported that in some sports there is a clear physical prototype necessary to reach the highest levels of performance (De Garay et al, 1974). It seems the body prototype proposed by researchers one decade ago is being substituted by another prototype based on specialization (Norton and Olds, 2001). These authors proposed that in sport, and also within the same sport, positions occupied in the playing field require unique physiological and physical attributes in order to get the highest performance. These issues are also important in handball because each specific position will require its own skills according to its task.

The aim of this study was to identify possible differences in the anthropometric characteristics in terms of individual playing positions in female handball players (centers, backs, wings, pivots and goalkeepers).

Methods

Subjects

A total of 130 elite female handball players (25.74 ± 4.84 years) with a regular competitive background in handball (14.92 ± 4.88 years) participated in this study. All of them were playing in the top Spanish professional handball league. The sample was divided according to the specific playing positions of 16 centers, 36 backs, 41 wings, 18 pivots and 19 goalkeepers.

Assessment Procedures

The study was approved by the San Antonio Catholic University Committee for research involving human subjects. All participants received verbal and written information about the study and gave informed written consent before anthropometric and conditional assessment.

Anthropometric evaluation

The International Society for the Advancement of Kinanthropometry (ISAK) protocol was used to determine the anthropometric profile of the handball players. Subjects were measured during one session and all of them postprandial state. Unilateral measurements were taken on the right side of the body. Participants wore light clothing and were barefoot.

Physical characteristics were measured in the following order: height, body mass, arm span, skinfolds, body girths and skeletal breadths. The anthropometric program included about 30 measurements. Height and weight measurements were made on a set of scales (Seca, Barcelona, Spain) with an accuracy of 0.01 kg and 0.001 m, respectively. Nine skinfolds (triceps, subscapular, biceps, axilar, abdominal, iliac crest, suprailiac, front thigh and medial calf) were measured by Holtain Skinfold Caliper with 10 g.mm⁻² constant pressure. Ten limb and trunk girths (arm relaxed, arm flexed and tensed, forearm, wrist, chest, waist, gluteal, thigh, calf and ankle) were measured using a Lufkin metal tape, (Lufkin Executive Thinline, W606PM, USA) and six skeletal breadths (biacromial, biepicondylar-humerus, biepicondylar, biiliocristal, bitrochanteric and bistyloid) were measured using an anthropometer (GPM, Switzerland) with an accuracy of 0.01 cm. Four lengths were measured using an anthropometer (GPM, Switzerland) with an accuracy of 0.01 cm in upper limbs (upper limb length, forearm length, hand length and hand width). Several variables were found: a) the body mass index (BMI) was calculated as weight (kg) divided by height (m²), b) sum of four (triceps, subscapular, suprailiac and abdominal) and six skinfolds (triceps, subscapular, suprailiac, abdominal front thigh and medial calf), c) fat free mass (FFM) (kg) using the method described by Lee (Lee et al,2000), d) selected anthropometric measures were used to determine somatotype following the methods described by Carter (Carter and Heath, 1990).

Statistical analysis

Standard statistical methods were used to calculate the mean and standard deviations. All data is expressed as mean \pm standard deviation (all data were checked for distribution normality and homogeneity with the Kolgomorov-Smirnov, Lilliefors and Levene tests). A one-way analysis of variance (ANOVA) together with a Tukey HSD post-hoc test was used to determine if significant differences existed among 5 playing positions (center, back, wing, pivot and goalkeeper). The $p \leq 0.05$ criterion was used for establishing statistical significance.

Results and discussions

Mean samples were 67.55 ± 8.06 kg, 171.31 ± 7.42 cm, 22.97 ± 1.86 (%) for weight, height and BMI respectively. Wings are less heavy, shorter and show less arm span, than goalkeepers, backs and pivots ($p \leq 0.001$). Additionally pivots are heavier than centers

($p \leq 0.001$). These results are not in line with those published by Hasan et al. (2007), but they are in line with the physical demands of each position (Srhoj, Marinovic and Rogulj, 2002).

No significant differences among playing positions were found, neither in BMI nor in sum of four and six skinfolds. Nevertheless, backs and pivots exhibit higher muscular mass than wings ($p \leq 0.001$).

In all breadths studied, wings show significant differences with backs and pivots ($p \leq 0.05$). Wings exhibit significant differences ($p \leq 0.05$) with goalkeepers in biepicondylar, biiliocrystal, bitrochanteric and bistyloid breadths. Wings show significant differences ($p \leq 0.05$) with centers in bistyloid breadth. In bitrochanteric breadth, statistical differences were found between centers and goalkeepers ($p \leq 0.05$) (Figure 1).

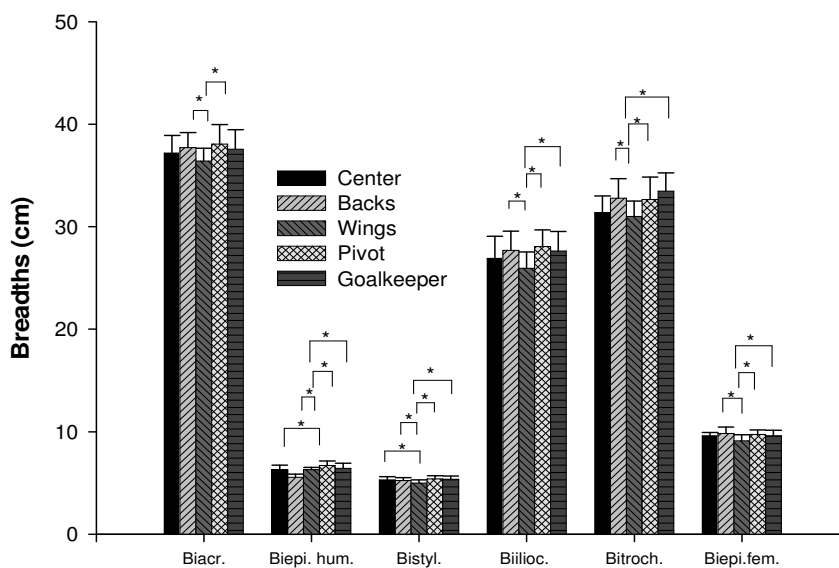

Figure 1. Bones breadths values. Significant differences among playing positions. (*) $p < 0.05$.

All girths analyzed show statistical differences ($p \leq 0.05$) between wings in contrast with backs and pivots. Likewise, centers show higher forearm girth than wings ($p \leq 0.05$). In gluteal girth, statistical differences have been found ($p \leq 0.05$) between pivots and centers.

The breadths are similar to the girths. They confirm the differences among the specific positions of pivots, and backs compared to wings. The goalkeeper needs an athletic body shape, with an important factor being longitudinal characteristics. Therefore biacromial, biiliocrystal and bitrochanteric breadths can contribute to a larger occupation of the goal area (Srhoj, Marinovic and Rogulj, 2002). This can be confirmed by the greater values that the goalkeeper shows in these breadths compared to wings and centers. It is notable that breadths are morphological parameters that are not modifiable by training and that can be related with strength levels (Malina and Bouchard, 1991). Therefore it could be an interesting aspect in the process of talent selection in handball (Srhoj, Marinovic and Rogulj, 2002; Vila, Fernández and Rodríguez, 2002).

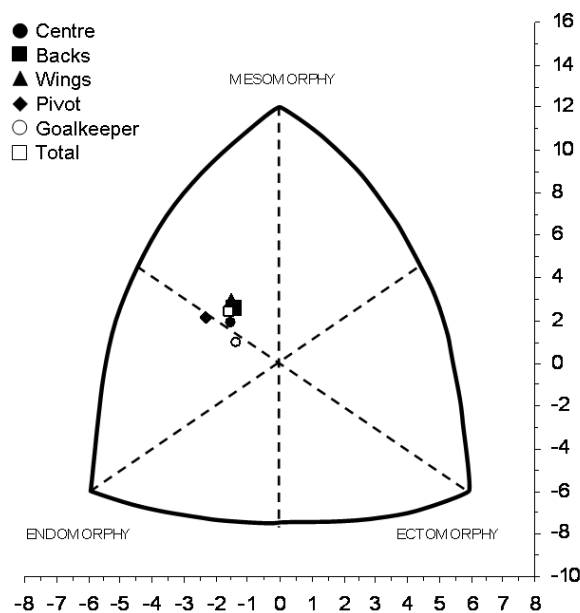

Figure 2. Representation of the somatotype in elite Spanish female handball players.

The total somatotype of the players in the study was characterised as mesomorphy-endomorphy (3.89 - 4.28 - 2.29). No significant differences in the three somatotype components were found among the five groups. Mesomorphy is the main component for centers (3.83 - 4.01 - 2.30), backs (3.80 - 4.40 - 2.31) and wings (3.72 - 4.44 - 2.18). Endomorphy is the main component for pivots (4.46 - 4.37 - 2.12) and goalkeepers (4.02 - 3.85 - 2.67). Ectomorphy is the least important component for all playing positions (Figure 2). When we analyzed the somatotype of playing positions, we did not find any differences among specific positions, but we can say that centers and pivots show an endomorphy-mesomorphy somatotype, where mesomorphy and endomorphy are predominant. These results concur with other papers published in male and female handball players (Malina and Bouchard, 1991; Bayios et al, 2006).

Conclusions

We can conclude that wings exhibit important anthropometric differences to the other specific playing positions in Spanish elite female handball players. In addition, mesomorphy is the principal component of the somatotype for all specific playing positions except pivots and goalkeepers. It can be confirmed that muscle mass in female handball players carries a significant importance.

hvila33@gmail.com

RELATIONSHIP BETWEEN HIGH LEVEL YOUNG HANDBALL GOALKEEPERS' PLAYING CHARACTERISTICS AND BODY COMPOSITION

Milvi VISNAPUU, Toivo JÜRIMÄE, Jaak JÜRIMÄE, Priit ALLIKIVI

University of Tartu, Tartu, Estonia

Summary: Aims of the study: Investigate the relationship between playing characteristics and anthropometrical parameters in young high performance goalkeepers. Subjects: 40 young male goalkeepers were studied at the 2006 European U18 Championships. Conclusion: According to the present study anthropometrical parameters are poor predictors of playing characteristics of young high-level handball goalkeepers.

Keywords: *young goalkeepers, body composition, playing characteristics*

1. Introduction

Short bursts of high intensity power production are typical in handball where high intensity physical activity separated by varying intervals of low and moderate intensity (Bencke et al. 2002).

The ability to run faster, to jump higher, to demonstrate greater agility and throwing velocity with great accuracy are the skills needed for successful play at all levels and all ages (Lidor et al. 2005). The actions of physical activity, which play a fundamental role in handball, are anaerobic in nature (Wallace & Cardinale 1997, Rannou et al. 2001). The goalkeeper's movements to make a save are explosive and anaerobic (Olsson, 2006, Oxyzoglou et al. 2008) as well.

Different sports require different motor abilities; in addition there are specific requirements on body composition and proportions (Bencke et al. 2002, Gabbett et al. 2006). Constitutional factors are important for the children's choice of sport (Pienaar et al. 1998, Damsgaard et al. 2001, Gabbett et al. 2006). The physique of players and anthropometrical characteristics may be the essential factors that guarantee success in sports games (van der Tillaar & Ettema 2004, Ostojic et al. 2006). Some studies have confirmed that body composition and some anthropometrical characteristics provide an advantage in certain sports (van den Tillaar & Ettema 2004, Gabbett et al. 2006). Within a sport, such as basketball, height is an advantage (Carter et al. 2005), and taller and more powerfully built players have an advantage in handball (Gorostiaga et al. 2005, Granados et al. 2007). In handball goalkeepers should be tall and have long body segments (Macovei, 2007). Similarly, it is easier to create a good goalkeeper from a tall person as they have a wider stretching range (Olsson, 2006).

The relationships between constitutional factors and anaerobic performance in handball have already been studied (Gorostiaga et al. 1999, Skoufas et al. 2003, Chaouachi et al. 2009, Mohamed et al. 2009, Zapartidis et al. 2009); however the relationship between the playing characteristics and anthropometrical parameters of handball goalkeepers has not been researched yet. The goalkeeper's role in a handball team is very specific and carries a high level of responsibility. The efficiency of the goalkeeper's actions plays an important role in the team's performance (Pori et al. 2009).

The aim of the present study was:

1. To investigate and compare playing characteristics in young high-level goalkeepers with different heights.
2. To investigate the relationship of playing characteristics with anthropometrical parameters in young high-level goalkeepers with different height.
3. To determine the impact of anthropometrical parameters on playing characteristics in young high-level goalkeepers with different heights.

2. Subjects and methods

In total 42 young male high-level goalkeepers participated at the 2006 European U18 Championships in Tallinn with the total average height of 190.5 cm out of whom 40 were studied. Two goalkeepers had no playing time at the tournament and thus they were not included in the sample of the study.

The subjects were divided into different height groups based on the aims of the study:

- * Goalkeepers with body height 189 cm or shorter (n = 18),
- * Goalkeepers with body height 190 cm or taller (n = 22).

2.1. Measurement of anthropometrical parameters.

Body height was measured to the nearest 1.0 cm; body mass was measured to the nearest 1.0 kg. The body mass index (BMI kg/m²) was calculated.

2.2. Measurement of playing characteristics

The following playing characteristics were measured:

- * The total number of shots, saves and % of saving;
- * Long distance shots - done, saved, % of saving;
- * 6 m shots - done, saved, % of saving;
- * Wing shots - done, saved, % of saving;
- * 7 m penalty shots - done, saved, % of saving;
- * Shots from fast break - done, saved, % of saving;

Data was gathered by official monitoring and recording during matches at the Championships.

2.3. Statistical analysis

The analysis was conducted using SPSS version 10.0 statistical software program (SPSS Inc., Chicago, IL). Standard statistical methods were used to calculate mean (\bar{X}) and standard deviation (\pm SD). Statistical comparisons between the groups were made using independent t-tests. Pearson correlation coefficients were used to determine the relationships between dependent variables. The stepwise multiple regression analysis was used to determine the effect of general anthropometrical parameters on the playing characteristics. The α level of 0.05 was used for all statistical tests.

3. Results and discussion

3.1. Anthropometrical parameters and playing characteristics of the high-level young goalkeepers with different heights

Mean anthropometrical parameters of the two groups (with height 189 cm or shorter and 190 cm or taller) of goalkeepers are presented in table 1. The results of the present study demonstrated that the playing characteristics of taller goalkeepers were more efficient in saved wing shots (39.9±20.0% and 35.3±16.0% respectively), defended long distance shots (46.1±13.9% and 43.9±11.3%) and defended fast break shots (43.9±11.3% and 18.9±7.0% respectively) but not significantly. At the same time the shorter goalkeepers' group demonstrated significantly better ($p < 0.05$) results in the percentage of saved 7m penalty shots, in number of saved 7m penalty shots and in number of 7m penalty shots performed them. In other playing characteristics shorter and taller goalkeepers showed similar results. Some earlier studies with handball (Olsson, 2006, Macovei, 2007) and soccer players (Matkovic et al. 2003, Hazir, 2010) confirm that goalkeepers are taller and heavier than players of other positions. The comparative study (Mansi, 2007) with Arab and European goalkeepers founded that taller goalkeepers demonstrated better playing characteristics. The present study didn't confirm this.

Table 1

Anthropometrical and playing characteristics in shorter and taller groups of goalkeepers

	Goalkeepers' height <189 or = 189 (n = 18)			Goalkeepers' height >190 or = 190 (n = 22)		
	$\bar{X} \pm SD$	Min	Max	$\bar{X} \pm SD$	Min	Max
Height(cm)	185.1±3.1	178.0	189.0	193.5±3.3	190.0	201.0
Mass (kg)	80.9±8.0	72.0	105.0	88.2±10.9	74.0	125.0
BMI	23.5±2.1	21.1	29.4	23.5±2.6	19.8	31.2
6m shots	29.8±11.5	10.0	59.0	24.1±16.0	0	70.0
6m saved	7.2±3.7	1.0	13.0	6.1	0	21.0
6m % save	23.6±9.0	10.0	41.7	23.0±10.7	0	41.0
Wing shots	18.9±10.9	5.0	41.0	14.6±7.4	5.0	33.0
Wing save	6.6±4.6	1.0	19.0	6.1±4.4	1.0	16.0
Wing % save	35.3±16.0	11.1	80.0	39.9±20.0	5.6	83.3
9m shots	39.2±22.1	11.0	88.0	39.1±19.6	10.0	77.0
9m saved	17.7±11.1	2.0	46.0	19.1±12.1	0	47.0
9m % save	43.9±11.3	18.2	58.6	46.1±13.9	0	64.3
7m shots	11.7±4.7*	4.0	20.0	8.3±4.5	1.0	18.0
7m saved	2.9±2.0*	0	7.0	1.6±1.8	0	8.0
7m % save	26.5±13.5*	0	50.0	19.3±16.3	0	50.0
FB shots	14.9±9.5	3.0	36.0	15.9±10.4	3.0	40.0
FB saved	3.1±2.1	0	7.0	3.9±3.3	0	13.0
FB % save	18.9±7.0	0	50.0	24.6±12.8	0	50.0
PL_time	139.6±96.8	33.0	353.0	204.3±120.2	18.0	386.0

* $p < 0.05$ between shorter and taller goalkeepers groups

3.2. Relationship of playing characteristics with basic anthropometrical parameters in two goalkeepers group.

Relationship between playing characteristics and anthropometrical parameters are presented in Table 2. The results of the present study demonstrated that no significant correlation existed between playing characteristics and body composition in the shorter goalkeepers group. In the taller goalkeepers group significant correlation existed between a few playing characteristics and anthropometrical parameters. Only 6m shots done and 6m shots saved had significant relationship with body mass ($r = 0.588$ and $r = 0.519$) as well as BMI ($r = 0.550$ and $r = 0.504$). It is interesting to note that there were many negative insignificant relationships between playing characteristics and anthropometrical parameters in shorter goalkeepers group, which probably explain negative effect of shorter body height on playing results. The sample of goalkeepers was too small to confirm this.

Table 2

Relationship between playing characteristics and basic anthropometrical parameters in shorter and taller goalkeepers groups

	Goalkeepers' height <189 or = 189 (n = 18)			Goalkeepers' height >190 or = 190 (n = 22)		
	Height	Mass	BMI	Height	Mass	BMI
6m shots	-0.320	-0.135	-0.032	0.282	0.588**	0.550**
6m saved	-0.247	-0.034	0.053	0.165	0.519*	0.504*
Wing shots	-0.156	-0.252	-0.216	0.335	0.334	0.249
Wing save	-0.269	-0.312	-0.240	0.112	0.130	0.073
9m shots	0.187	0.160	0.104	0.218	0.353	0.335
9m saved	0.098	0.217	0.191	0.227	0.312	0.275
7m shots	0.027	-0.266	-0.284	0.224	0.385	0.352
7m saved	-0.073	-0.172	-0.155	0.024	-0.176	-0.190
FB shots	0.001	0.050	0.059	0.293	0.466*	0.418
FB saved	0.269	0.019	-0.067	0.375	0.376	0.286

* $p < 0.05$; ** $p < 0.01$

The playing characteristics were selected as dependent variables and anthropometrical parameters as independent variables for stepwise multiple regression analyses (Table 3) to determine the impact of basic anthropometrical parameters on playing characteristics. There were few playing characteristics, which were significantly influenced by anthropometrical parameters. Only some of the playing characteristics in taller goalkeepers group were predicted by the anthropometrical parameters. Body mass influenced number of saved shots from 6m by 23.3% ($R^2 \times 100$; $p < 0.013$) and amount of fast breaks by 17.7% ($R^2 \times 100$; $p < 0.028$) in taller goalkeepers group. Body height influenced number of shots done from 6m by 34.6% ($R^2 \times 100$; $p < 0.004$) in taller goalkeepers group. The major finding of this study was that the anthropometrical characteristics are relatively poor predictors of playing characteristics of young high-level handball goalkeepers.

Table 3

Stepwise multiple regression where playing characteristics are dependent variables and anthropometrical characteristics are independent variables.

Dependent variable	Goalkeepers' group	Independent variables	R ² x100	F	P
6m shots	Shorter GK	Height	4.63	1.8	<0.195
	Taller GK	Height	34.6	10.6	<0.004
6m saved	Shorter GK	Height	0.24	1.0	<0.322
	Taller GK	Body mass	23.3	7.4	<0.013
Wing shots	Shorter GK	Body mass	0.52	1.1	<0.312
	Taller GK	Height, mass	6.95	1.9	<0.194
Wing save	Shorter GK	Body mass	4.69	1.7	<0.208
	Taller GK	-	-	-	-
9m shots	Shorter GK	-	-	-	-
	Taller GK	Body mass	8.09	2.8	<0.106
9m saved	Shorter GK	-	-	-	-
	Taller GK	Body mass	5.24	2.2	<0.157
7m shots	Shorter GK		2.32	1.4	<0.253
	Taller GK	BMI, mass	10.5	3.5	<0.082
7m saved	Shorter GK	-	-	-	-
	Taller GK	-	-	-	-
FB shots	Shorter GK	-	-	-	-
	Taller GK	Body mass	17.7	5.5	<0.028
FB saved	Shorter GK	Height	1.42	1.2	<0.280
	Taller GK	BMI, mass	12.2	2.5	<0.113

4. Conclusions

In conclusion we suggest:

1. Anthropometrical characteristics are relatively poor predictors of the results of playing characteristics of young high-level handball goalkeepers.
2. Only shots from fast break and 6m shots in taller goalkeepers group were predicted by the anthropometrical parameters.
3. Shorter goalkeepers' group demonstrated significantly better ($p < 0.05$) results in the percentage of saved 7m penalty shots and in the number of saved 7m penalty shots.
4. Taller goalkeepers were insignificantly more efficient in saved wing shots, defended long distance shots and defended fast break shots.

 milvi.visnapuu@ut.ee

LOAD INTENSITY COMPARISON OF WOMAN PLAYERS AGED 17-18 IN COMPETITIVE AND WARM-UP MATCHES IN HANDBALL

Jan BELKA, Karel HULKA, Zdenek SVOBODA, Vaclav KOSTELNIK

Faculty of Physical Culture at Palacky University in Olomouc, Czech Republic

Summary

The study analyzes load intensity of woman players aged 17-18 in competitive and warm-up matches in handball – team DHK Zora Olomouc. The load intensity results from both competitive and warm-up matches that are here compared. Three competitive and three warm-up matches were analyzed. 12 players were monitored in each game. The goalkeepers were not involved. The maximum heart rate (HR_{max}) was defined by the help of Beep test.

Keywords: *Handball, heart rate, match, load intensity*

Introduction

Performance in sport games is influenced by several factors. According to Táborský et al. (2007, 21), sport performance is a special kind of athlete's behavior in specific competitive conditions. This behavior is determined by two sets of causes – inner state of athlete's organism, which can be labeled as performance preconditions, and outer state of environment, which we define as performance causes. Game performance can be understood as some kind of set collecting all kinds of movements and it is formed of specific subsets of different levels: physical – biomechanical, chemical – biomechanical, biological – anthropomorphical, physiological, psychological, and social (Táborský, 2007, 21).

Authors (such as Dobrý and Semiginovský, 1988; Moravec, 2004; Votík, 2005; Psotta, et al. 2004; Sús, et al. 2009) who deal with game performance (HV) during a match, claim that one of the important part of a game performance is also a functional preparation in the meaning of player's specific adaptation to load intensity during a match.

Several authors (Ramsey et al. 1970; Cohen, 1980; Beam, 1994; McInnes et al.1995; LópezCalbet, 1997; Janeira & Maia, 1998; Zen Lin, P. et al. 1998; Refoyo, 2001; Capranica et al., 2001; Rodriguez-Alonso, 2003; Barbero-Alvarez et al., 2008; Vaquera et al. 2008; Matthew & Delextrat, 2009; Bělka et al., 2010; Castellano & Casamichana, 2010) focus on heart rate monitoring during competitive matches in sports such as basketball, football, volleyball, beach football, inside five-a-side football and rugby. Based on the gathered data, most of the authors formulated their recommendations for training process for certain sport games. More concretely, in which load intensity zones should players be during a training process. A few foreign authors (Lupo & Seriacopi, 1996) have presented their results about heart rate monitoring from warm-up matches relatively recently.

Methodology

Monitored group

The monitored group consisted of women players (n=17) from DHK Zora Olomouc from the Czech Republic; the team plays 1st junior league. In the season 2010/2011, the team was placed on 5th (out of 12) place. This team has trainings five times a week and has one competitive match at the weekend. The monitored group consisted of 17 players (8 wings, 2 pivots, 7 center, right and left backcourts). At each match, there were 12 players except the

goalkeepers. Goalkeepers were not included in the monitoring because of the post specificity. The results from former research (Bělka, Hůlka, Elfmark, & Trubačová, 2010) confirmed the post specificity and load intensity difference during a match in comparison with other posts.

Table 1. Specification of monitored group

	Age	Playing position	Height (cm)	Body mass (kg)	HR _{max} (beats/min ⁻¹)	VO ₂ max	BMI (kg/m ²)
Participant 1	18	Wing	162	60	195	40,87	22,86
Participant 2	18	Wing	173	60	191	32,89	20,04
Participant 3	17	Wing	161	64	196	56,84	24,69
Participant 4	17	Wing	160	52	195	47,41	20,31
Participant 5	17	Wing	160	55	204	44,93	21,48
Participant 6	17	Wing	165	60	200	47,72	22,04
Participant 7	17	Wing	169	61	192	50,26	21,36
Participant 8	17	Wing	165	56	198	47,41	20,57
Participant 9	17	Pivot	164	64	200	43,18	23,79
Participant 10	17	Pivot	170	63	196	43,65	21,79
Participant 11	17	Center	165	60	205	49,24	22,04
Participant 12	17	Center	183	85	204	52,61	25,38
Participant 13	17	Center	182	83	196	49,55	25,06
Participant 14	17	Center	162	56	201	43,34	21,34
Participant 15	17	Center	172	60	192	36,20	20,28
Participant 16	17	Center	179	64	201	39,52	19,97
Participant 17	18	Center	182	60	196	37,80	18,11
Mean	17,8 ±0,38		169,05±7,88	62,52±8,48	197,76±4,20	44,91±6,01	21,83±1,93

Research description

The research was done in three warm-up matches (August 2010) which were a part of tournament, and another three competitive matches played in the season 2010/2011. The duration of warm-up matches was 2 x 25 min with 5 min break and the duration of competitive matches was 2 x 30 min with 10 min break. To be able to analyze data about periods of time spent on a court, substitution of players and breaks, all the matches were recorded on a digital camcorder Panasonic SRD – H80 and also recorded into a match report. The temperature was in all sport halls between 23 – 26 °C. The results from warm-up matches were following 20:20, 21: 7, and 13:16. The results from competitive matches were 33: 17, 41:18, and 20:26. The defensive systems 0:6 and 1:5 were played alternately in all of the matches (both warm-up and competitive). In a sequential offense, a system with only one center forward was used. During each match, the players drank ionic drinks.

The heart rate was monitored by the means of Team Polar sporttesters. This sporttesters do not have a wristwatch, which is their biggest advantage. The received data were after each match saved into a computer and evaluated afterwards. SW PolarPrecision Performance software was used to evaluate the data. 60 records from six matches were evaluated. Six records were from an unknown cause empty, and therefore not used. These intervals were chosen in preference to 5-s intervals to reduce sampling error without compromising the quality of interpretation (McInnes et al., 1995). The stop watch on the heart rate monitor was synchronized with the starting time of the game and heart rates were averaged to calculate the mean value during total time and the mean value during live time, respectively. Total time was defined as the time during which the player was on the court (i.e. excluding breaks between half time, and time on the bench) including breaks such as 7-meter throws (if the time was intermitted), out of bounds, and time-outs. Live time comprised only the time that the ball was in play and the clock was running (McInnes et al., 1995).

Maximal heart rate was monitored by Beep test, which was practiced during one training process in a sport hall. VO₂max was determined based on the results from Beep test. Anaerobic zone was computed mathematically.

Statistics

All basic statistic quantities for a single type of match and players' position were computed. ANOVA Kruskal-Wallis test (3 players' positions) and Wilcoxon pair test were used to compare each position. The significance level was $p < 0.05$. Descriptive statistics was also used (percentage, absolute and relative frequency, arithmetic mean).

Results and Discussion

Analyzed results of load intensity of the present study are clearly presented and explained (with necessary comments) in the following graphs.

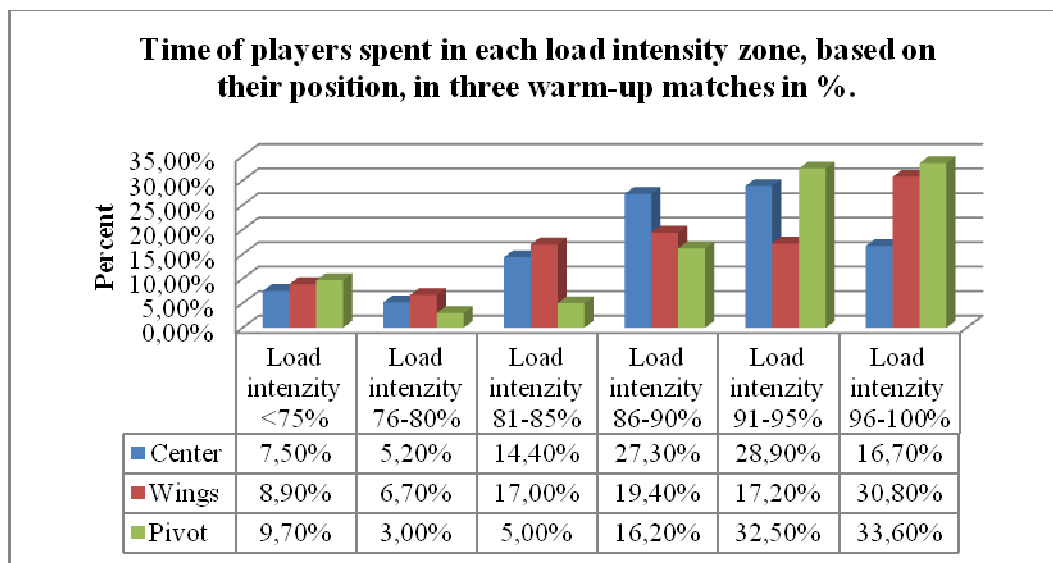

Picture 1. Time of players spent in each load intensity zone, based on their position, in three warm-up matches in %.

Based on the heart rate, centre backs were the most loaded. 82 % of the total time the players spent above the anaerobic zone (picture 1.). During the match, the centre backs were in a constant contact with competitive players, both in offensive and defensive actions. From the perspective of the game system, the center backs participated on fast breaks too. The combinations were often based on the cooperation of center back and pivot. Most of the signals were cooperated with pivot. The least loaded players were wings. In anaerobic zone, they spent only 67 % of the total time. Mainly in a progressive attack, their activity was very low because of their tactic role to widen the game and make positional movements in the corner of the court. On the other hand, in the fast breaks, wings were in the first wave. In this phase, wings spent 31 % in the load intensity zone of 96 - 100 % HR_{max}. The average time spent by all players above the above aerobic level was 74 %, 44 minutes respectively. In the warm-up matches, there were 43 goal attacks within a match. High amount of errors (15 errors per a match) such as technical errors (steps, attack faults, double dribbling, wrong pass, entering goal perimeter etc.) appeared during all matches.

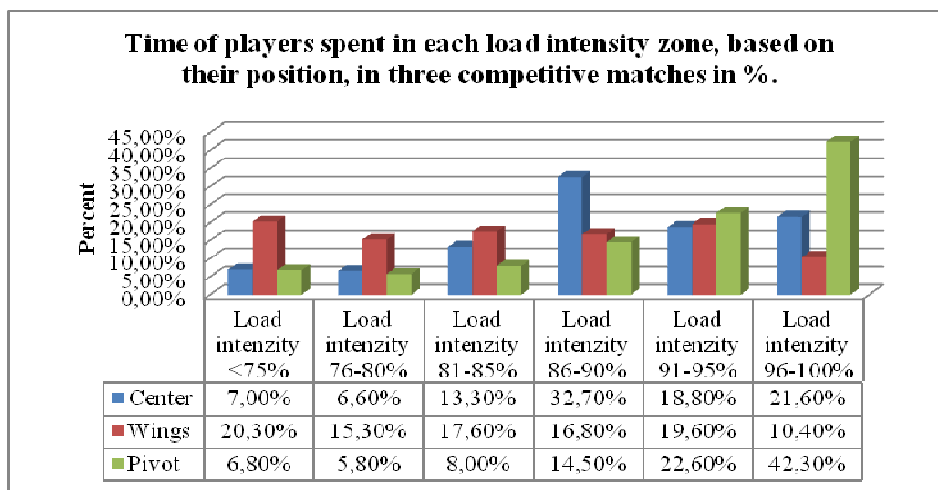

Picture 2. Time of players spent in each load intensity zone, based on their position, in three competitive matches in %.

Based on the heart rate, centre backs were the most loaded. 79 % of the total time the player spent above the anaerobic zone, 47 minutes respectively (picture 2.). There was a significant difference of $p=.043$ between center backs and wings. The centre backs were very initiative in both offensive and defensive actions. The results may be influenced by the fact that one of the center backs participated as a forward defensive in the system 1:5 and also very often participated on fast breaks. On average, the players spent 25 % in the load intensity zone of 96 – 100 %. 66 % of the total time the players spent above 85 % of HR_{max} . In competitive matches, there were 48 goal attacks and 9 technical errors within a match (steps, attack faults, double dribbling, wrong pass, entering goal perimeter etc.).

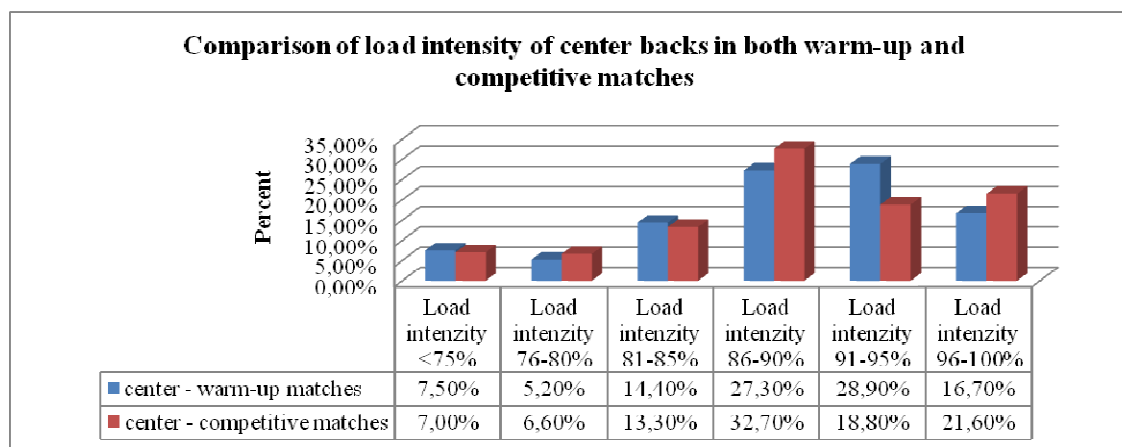

Picture 3. Comparison of load intensity of center backs in both warm-up and competitive matches

The difference between load intensity in each zone below the anaerobic level of centre backs in warm-up and competitive matches is minimal (picture 3.). The difference of statistical importance has not appeared even in the zones above the anaerobic level. The difference in the load intensity between 91 – 95 % was the closest to be statistically important ($p=.233$). The difference below the anaerobic zone was minimal. There was no significant difference between the warm-up and competitive nature of the match. The centre backs succeeded in warm-up matches in 26 % in shooting, whereas in competitive ones it was 30 %. The difference between shooting (5 tries) was in the advantage of competitive matches. As a result of the beginning of a training process, lower success can be caused by not doing enough positional shooting before the tournament started. All the supportive determiners are the same in both types of matches.

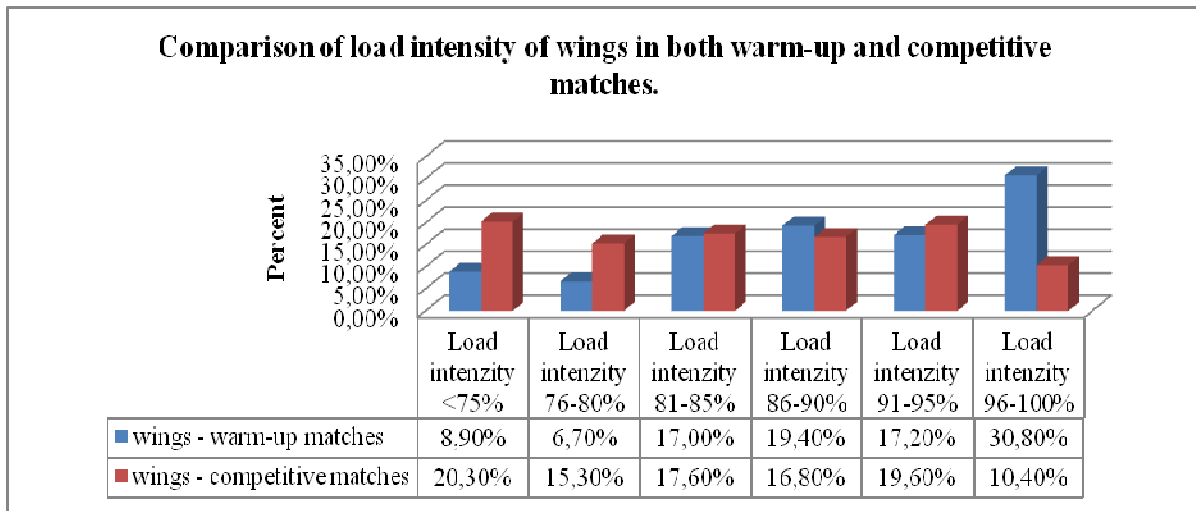

Picture 4. Comparison of load intensity of wings in both warm-up and competitive matches.

In warm-up matches, the wings stayed longer in the zones of higher load intensity (picture 4.). In the warm-up matches, the load intensity was above the anaerobic level 67 % in comparison with 47 % from the competitive ones. The difference is not of statistical importance ($p=0.379$). The difference results from fast breaks, where wings took part in, which were not completed. Afterwards they had to run back to their defensive positions as fast as possible. In the competitive matches, the shooting success was higher and after scored goal, the competitors threw-off the ball very slowly. Hence, the wings did not have to run back in a high intensity. This fact is also one of the reasons that influenced the heart rate. The shooting success of wings in the warm-up matches was 35 % in comparison with 42 % from the competitive ones.

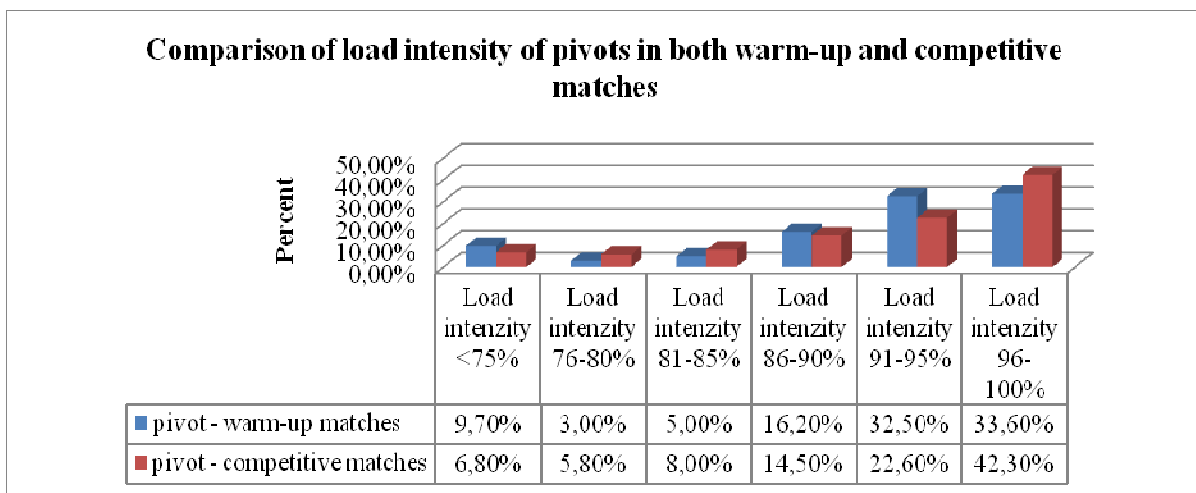

Picture 5. Comparison of load intensity of pivots in both warm-up and competitive matches

The difference in each load intensity zones is not of statistical importance (picture 5). The pivots had in both matches quite similar game tasks. Only in some phases during the match, pivots appeared targeting the center forwards in the defense formation 1:5. Due to this fact the percentage difference is higher in the load intensity zone of 96 – 100 % HR_{max} . As stated before, we have again come to conclusion that pivots are the most loaded players in the match. In warm-up matches pivots appeared above the anaerobic level in 82 % in comparison with 79 % in competitive ones. The shooting success of wings in the warm-up matches was 57 % in comparison with 71 % from the competitive ones. On average, pivots shot in both matches seven times on the goal.

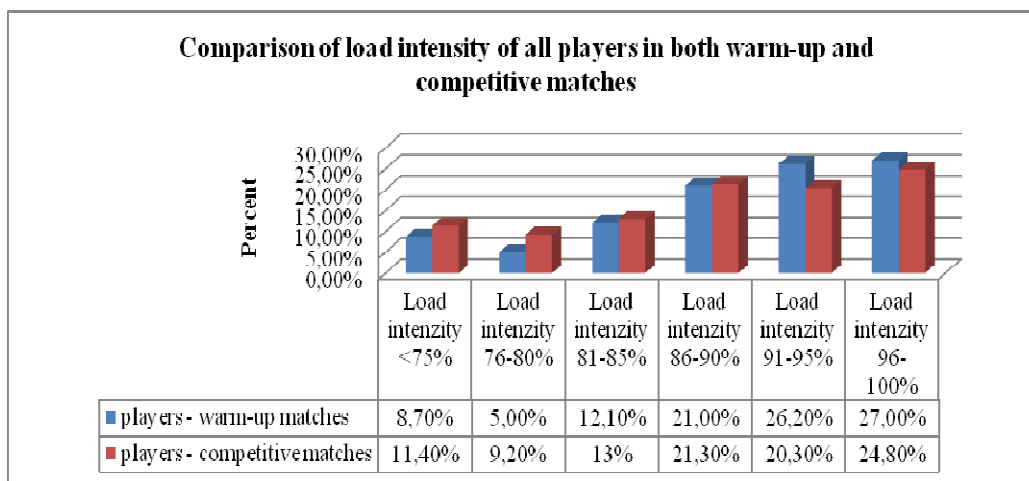

Picture 6. Comparison of load intensity of all players in both warm-up and competitive matches

The picture 6 interprets all results received from all monitored players during both warm-up and competitive matches. Again, there was no difference of statistical importance between single zones. The players spent 42 minutes above the anaerobic level. Higher (of 8 %) load intensity was reached during the warm-up matches. However, this difference was not again statistically important ($p=.579$). One of the factors can be the similar physical and technical level of players from the competitive team, as one of the matches was a semi-final match on the tournament. Motivation is one the most important factors.

Primarily, people do sport for collective fun, for the feeling to be needed and for success. In the connection with motivation we can find a term “rewarding” – inner and outer. Trophies, medals, money or simple praise belong to the outer rewards. On the other hand, inner satisfaction such as fun, happiness from success belongs to the inner one (Martens, 2006). When the match is already won, the success satisfaction can appear before the match ends. It can lead to the reduction of one’s effort and the decrease in players’ load intensity.

In our study the players appeared above the anaerobic level in 74 % (warm-up match) and 66 % (competitive match) of the time spent on the court respectively. Similar study was done on players from 1st and 2nd women’s league in competitive matches (Bělka et al., 2010). The players spent 84 % above the anaerobic level, 82 % of the time respectively.

Conclusion

This study indicates the suitability of warm-up matches to be integrated into the training process because of the similar load intensity with competitive matches. Between both warm-up and competitive matches and their single zones, for all posts there was no difference of statistical importance. The players spent above the anaerobic level 74 % (warm-up match) and 66 % (competitive match) of the time spent on the court. It is important to mention “motivation” as one of the leading factors that could partially influence the results. The study confirmed pivot to be the most loaded player in both types of matches. In warm-up matches pivots appeared above the anaerobic level in 82 % in comparison with 79 % in competitive ones. One of the positive advantages of this study is the possibility of using sport testers without any motional limitations. The biggest advantage is that wristwatch is not a part of sport testers, which is banned by handball rules. The results of this study are limited by different playing time and low number of analyzed matches. To interpret this result, it is necessary to simultaneously take into account the court motion analysis. Hence, the presented results cannot be generalized.

jan.belka@upol.cz

SOME PATHS OF MIGRATION IN HANDBALL – TERRITORY CHARACTERISTICS

Marta BON, Mojca DOUPONA TOPIČ, Marko ŠIBILA, Primož PORI, Bojan LESKOŠEK

Faculty of Sport, University of Ljubljana, Slovenia

Summary

In this study, some characteristics of the transfers of handball players in the European market are analysed. Particular attention is devoted to an analysis of the proportion of individual countries according to the group of countries. Countries were divided according to geographical location or historical features. Additionally, the research presents the changes in the nature of transfers and trends of transfers in handball to the year 2006. All data were obtained from the European handball federation (EHF), which assumes the responsibility for all transfers of contract players within Europe in accordance with the International Handball Federations' (IHF) "Player Eligibility Code" and the "IHF Regulations for Transfer between Federations". The data include transfer characteristics (start and finish release, country from and country to) and socio-demographical characteristics (age and gender). For the purposes of this research, χ^2 and one-way ANOVA analyses were carried out (SPSS 10.1 for Windows). The sample of measured subjects included 3,602 women and 5,433 men who have moved from a club in one country into another club in a different country between the years 1996 and 2006. Altogether, 20,650 transfers were made in this period; (13,103 (63.5%) men and 7,547 (36.5%) women). The dynamic of transfers was nearly equal in Western (12.8%) and Eastern (12.5%) Europe; it was especially strong in Scandinavian countries (11.1%), and in the former Yugoslavia (9.2%). The ages of handball players were between 10 and 48 years ($M=25$ yrs). In the analysed period, male handball players transferred more frequently (60.1% of all transfers) than female players. The proportion of transfers according to gender is nearly equal in Western and Scandinavian countries. In other areas (ex-Soviet Union, E. Europe, ex-YU), we found significant differences in gender; female players transferred less frequently than male.

Introduction

Most researchers agree that athletic talent migration involves processes that are evolving and developing. As with athletic labour migration in general, and specifically in handball, it is a dynamic subject involving country, club/team and athletes in a complex chain of negotiations over rights and responsibilities. The global migrations of athletic workers have increased dramatically in magnitude, composition, and direction in recent years.

As national stories are increasingly told through popular culture and the media, some people turn to sport, sport events, sport venues, and athletes as representations of their nation and national values (Doupona Topič, Coakley, 2010). Sport stories regularly glorify chauvinism and militarism, but regardless of their specific focus, they tend to spark an awareness of the nation and inspire public discourses that create at least temporary unity among citizens, feelings of pride, and opportunities to assert and seek affirmation of national identity claims on broader geopolitical stages (Bairner, 2001, 2009;; Fox, 2006; Elliott & Maguire (2008) Hogan, 2003; Lechner, 2007; Maguire, 1999; Maguire et al, 2009; Merkel, 2008; Poulton, 2004; Rowe, 2003; Shobe, 2008; Tuck, 2003).

The migrations of athletes have become a prominent feature of global sport (Maguire, 1999; Maguire, Jarvie, Mansfeld, & Bradley, 2002). In many sports, athletes are migrating within nation states, between nation states on the same continent, and beyond their own continents.

The result is a contemporary sporting culture in which athletic labour flows across increasingly distant geographical, political, cultural, ethnic, and economic boundaries.

On are of Handball some researches was done till today to (f.e. Agergaard, 2008; Bon, Doupona Topič, 2008 & 2010; Bon, Leskošek, Doupona Topič, 2011).

Methods

The data include transfer characteristics (start and finish release, country from and country to) and socio-demographical characteristics (age and gender). For the purpose of the research, χ^2 and one-way ANOVA analyses were carried out (SPSS 10.1 for Windows). The sample of measured subjects included 3,602 women and 5,433 men who have had moved from their club in one country into another club in a different country between the years 1990 and 2006. For 373 people there are no data about the start of the first release.

Results



Figure 1: All transfers to year 2006

To 2006, a total of 20,650 transfers were made; (13,103 (63.5%) men and 7,547 (36.5%) women.

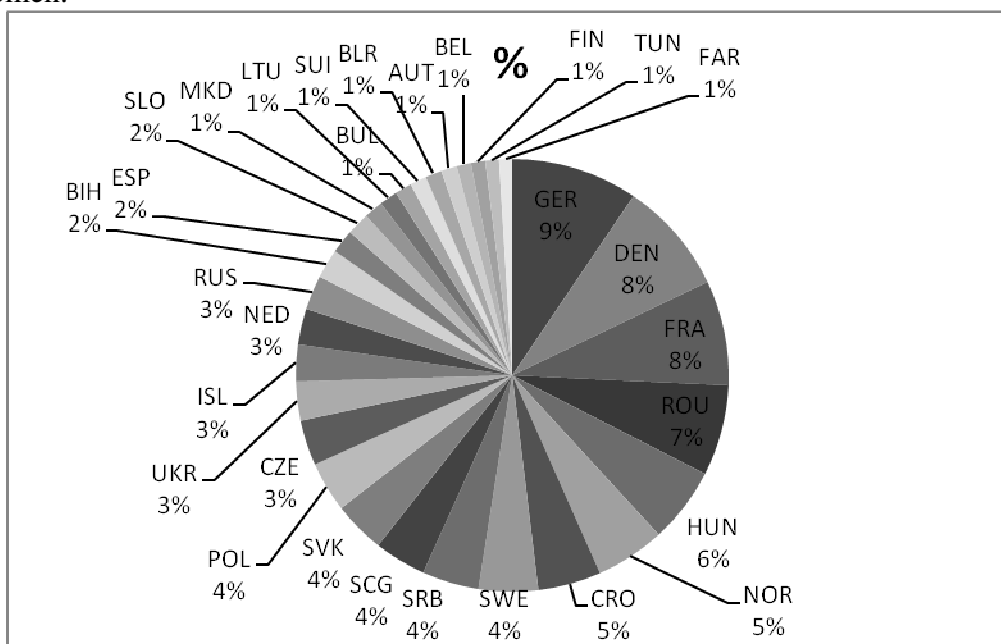

Figure 2: Overview of transfers in Europe

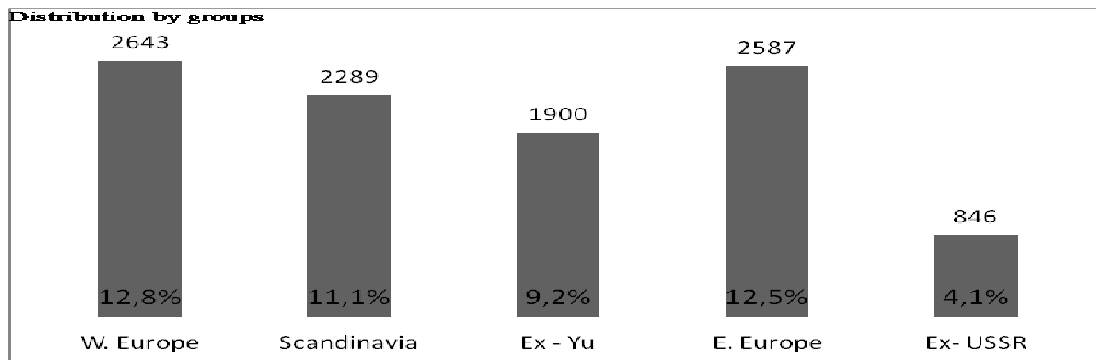

Figure 3: Amount of transfers (%) by groups of counties

Germany is the leading country in frequencies of transfers (Figure 2): 9% of all transfers in handball were done there. If we analyse the group of countries' transfer dynamic (Figure 3), Western (12.8%) and Eastern (12.5%) Europe were nearly equal; Scandinavian countries (11.1%), and ex-Yugoslavia (9.2%) also had intense activity. The ages of handball players were between 10 and 48 years (M=25 yrs). In the analysed period (Figure 1), male handball players transferred more often (60.1% of all transfers) than female players. The proportion of transfers according to gender is nearly equal in Western and Scandinavian countries (Figure 3).

Concerning the frequencies of transfers in western Europe (W. EU), Germany (37%) is the leading country (Figure 4); Romania (29%) in E. Europe (E. EU) and Ukraine (37%) in the ex-USSR group. In the Scandinavian group Denmark is the most frequently country (39%), and in the ex-Yugoslavia, Croatia (37%). In both countries handball is one of the most popular sports.

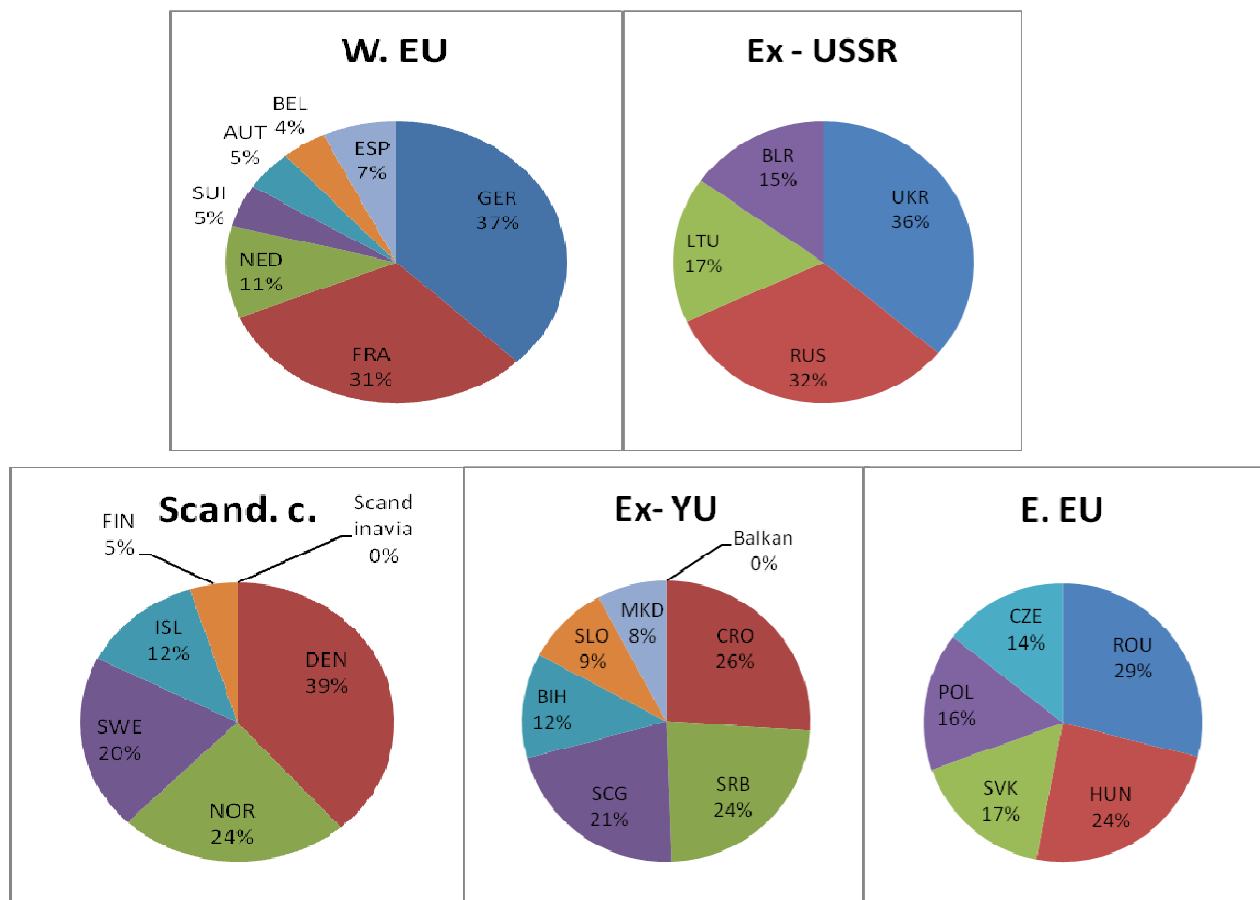

Figure 4: Distribution by groups of countries for five groups

Discussion

During these early years of the twenty-first century, sports constitute sites at which nation-states and their representatives can make highly visible identity claims that resonate with citizens and receive at least implicit reaffirmation on regional and global stages. Few other activities offer such opportunities. Therefore, many nations turn to sports when there is a desire to promote national pride and identity in the service of achieving important goals (van Hilvoorde, Elling, & Stokvis, 2010).

It is also clear that player migration is fundamentally an institutional response to economic crises and opportunities. Of course in handball, as in other sports, economic power does not automatically translate into sports supremacy. Nonetheless, it is apparent that sports labour migration, and those who are fortunate enough to engage in it, is an important reflection of prevailing economic relations.

Migration research has mainly dealt with the forces that affect migration and how strongly they have affected it, but little has been done to determine the influence of migration as an equilibrating mechanism in a changing economy. The movements of migrants clearly are in the appropriate direction, but we do not know whether the numbers are sufficient to be efficient in correcting income disparities as they emerge. There is a strong presumption that they are not (Sjaastad (2011). We have the very similar question in sport or/and in handball.

Conclusion

We are trying to systematically analyse some paths of migration handball. Many open questions remain in migration politics in sport. The question of who gains the greatest benefits is worth future study. Economists and others are generally dissatisfied with the past performance of migration in narrowing geographic income differentials, in spite of the tremendous amount of internal migration taking place in sport in European handball.

One very special area is that of ex-Yugoslavia; the frequencies of transfers are very high, and dynamic. In a small area, there are major differences.

The migrations of handball athletes are an example of heightened globalisation, regionalisation or internationalisation. But also sign of the further development of handball as an important, improving and dynamic sport discipline. Our data were to the year 2006. For further research, it would be good to analyse new trends and new models of transfers with more current handball data.

Marta.Bon@fsp.uni-lj.si

GOALKEEPER – SPECIFIC TRAINING FOR YOUNGSTERS: CHARACTETIZATION OF THE IMPORTANCE AND STRUCTURE IN THE FORMATION PROCESS OF HANDBALL GOALKEEPER

Joao António Pereira Rodrigues de CASTRO,
Pedro Jorge Richheimer Marta de SEQUEIRA, Carlos Manuel Cerqueira CRUZ

Lusofona University of Humanities and Technologies, Lisbon, Portugal

Summary

The study aims to characterize the training of the Handball Goalkeeper, identifying the purpose of the exercises performed and the structure of training for athletes between 11 and 18 years in 24 training sessions. The exercises were considered in the study according to their objective, and the Goalkeeper specific exercises for developed components, moment of occurrence and mode of organization, and classified under the validation of 6 specialists.

Keywords: Goalkeeper, Training, Specific, Youngsters, Handball

Introduction

Currently, it appears that the changing trends of the game show that the Goalkeeper take an increasingly important role in achieving victory in Handball, so it is vital that the various structures and types of preparation take place in the Goalkeeper sports training.

The role of the goalkeeper is the most specific in the game and has its own characteristics in the game of handball. This specificity leads Bárcenas & Roman (1991); Rosal Asensio (2004) and Olsson (2006) to consider **the goalkeeper: an individual athlete but within the collective**, whose ultimate objective is to prevent the opposing team's goal.

Regarding the importance that the coaches dedicated to Goalkeeper preparation in the observed training sessions, it collects a tendency on the training process of young Handball team. We seek to verify the sustainability of the current paradox reported in the theoretical references between the importance of the Goalkeeper in Handball and the training time dedicated to the Goalkeepers in Portugal, and specially in his formation process (Ribeiro, 2002; Volossovitch *et al.*, 2002; Casimiro, 2003; Olsson, 2004; Olsson, 2006), verifying if all the observed training sessions of the several young age groups had training activities to developed General and the Specific preparation of the Goalkeeper.

The position of goalkeeper is considered a specific post with a late maturation compared to other specific positions in Handball. The pedagogic theoretical references (Alvarez, 2003; Bermúdez & Chaurra, 2003) say that Goalkeeper specific training should be developed with a higher volume in the training sessions with youngsters after the age group U-14. We try to confirm, in the observed training sessions, if the GK specific training time is higher in the age groups U-16 and U-18, whereas the GK general training time is higher in the age groups U-12 and U-14.

We also try to make a characterization of the structure of the Goalkeeper Specific Training in the formation process of the athletes, regarding the more developed training components; the distribution of those training activities through different moments of occurrence during the session and also, in with modes of organization.

In this characterization of the specific training structure we will see if in the observed training session, this type of preparation is developed covering all training, because the importance they have in the Goalkeeper preparation (Zeir, 1981; Pinheiro, 1993; Ribeiro, 2002; Olsson, 2004 and 2006).

Further pretend to confirm if the specific training activities for the Goalkeepers occurrence in the different moments of the training session (Warm Up, Main part, Final part), not occurring mainly in one of those moments, since, as for the training of field players, all the moments are important to work the Goalkeeper preparation.

Finally, this study pretend to review the modes of organization, verifying if the collective organization is often more used in older age groups, and if, younger age groups the coaches mainly use the individual modes of organization, accordingly with the theoretical references (Equisoain, 2001; Ribeiro, 2002). The use of incorrect training modes of organization with young Goalkeepers is one of the key-ideas of RFEBM (1988) regarding this subject. They say that the Goalkeeper specific training time is often reduced and inadequate.

For the different types of training in the preparation of the inicial training for young Goalkeepers, Pinheiro (1993), Ribeiro (2002) and Olsson (2006) refers to **physical preparation** as the most important. The emphasis is justified because without an adequate level of physical preparation, the remaining components of the training and in particular the technical preparation, but also, the tactical preparation are compromised. As the stages of the inicial formation of the GK advances, the specific physical preparation will increase as the general preparation should decrease.

The Goalkeeper can realize technical exercises to develop the phases of Pre-Save, the Save of shots and Post-Save. The **technical preparation** developed in the right way leads to a high efficiency, and has an individual character. Several authors develop the technical questions of the preparation according to the “Goalkeeper School” addressed. M. Olsson (personal communication, October 13, 2006) also states that the work that favors the characteristics of the Portuguese Goalkeeper, is the methodology based on open-defense techniques, not stereotypical, and the strong influence of physical fitness and technique, in order to bridge the physical and anthropometric *déficit*.

According to Ribeiro (2002), the high efficiency of a Goalkeeper requires a higher **tactical preparation** and percepcion, which allows him to know extensively the opponents types of shooting, by observing the video of the previous games; verbal communication to help the defense and to give wrong information to the oponents shooters, during the game. Olsson (2004) and (2006) states that, the tactical training objectives of the Goalkeeper have contents of individual (situation 1xGK) and collective preparation (collaboration between the Goalkeeper and the field players).

It is recognized as theoretical principle that, **psychological preparation** is very important for an athlete, but even more in Goalkeeper position. The Goalkeeper position needs higher levels of concentration and attencion than the filed players. Thiel & Hecker (1993) corroborates this opinion, refering that the GK is the most requested player during a game from a psychologic point of view. Equisoain (2001) referes that a Goalkeeper with high personality use a psychologic superiority over his or the opposite team, that can be decisive.

The **theoretical preparation** should be structured in straight relation with the tactical preparation and the psychological preparation. The study of the opposite shooter padrons is an integral part of the theoretical preparation, trough: the information exchanged between coaches and GK; copying the opposite shooter padrons in the training sessions; and analysing the videos of the opponent team.

Regarding the objective of the GK training drills, the theorical references consider:

1- General Training for Goalkeeper – use of training activities related to general preparation, developing some specific and/or non specific behaviors of the Goalkeeper functions in Handball, such as technical aspects, but also of the physical and tactical preparation as an Handball player (Zeir, 1981). It also includes, GK training submitted to the team needs, dedicated to the tactical preparation of the team and the technical preparation of the players shooting abilities (Zeir, 1981; Alvarez, 2003).

2- Specific Training for Goalkeeper – use of training activities related to specific preparation, stimulating the different actions related to GK functions in Handball, such as:

- *Collective and Group training* – cooperation between GK and the defenders in training drills and game-exercise (Zeir, 1981; Equisoain, 2001);
- *Goalkeeper training using the field players* – Goalkeeper training with shooters, co-working for the GK specific training (Torres Tobio, 1998; Alvarez, 2003). It's important not to be confused with shooting drills;
- *Goalkeeper Individual or Group Training* – during the team training, the team GK realize training drills, establishing a relationship between the technique and the individual characteristics of each GK, making some technical corrections (Antúnez Medina, 2003);
- *Autonomy of the Goalkeeper* – Goalkeeper develop physical and technical specific drills in individual training sessions, independent of the other teammates (Torres Tobio, 1998; Antúnez Medina, 2003; Greco, 2003). M. Olsson (2006) says that, an important problem in Portuguese Goalkeeper training is the lack of autonomy training.

Regarding the characteristics of Goalkeeper training drills, Castelo (2002) and Koning (2005) *cit. in* Cruz (2007) define the structure of the exercises based on organization criteria:

Individual exercises or with a teammate, drills that stimulate the GK to exercise their training contents in an independent mode, with the purpose of fulfilling the training tasks autonomously, with different activities than the rest of the team (in articulation or not with the rest of the training session for the team) to developed the individual characteristics.

Group exercises or reduced game drills, are organized in small sub-groups. This drills are realized during the training session for the team, developing two modes or organization: 1- work with the several GK of the team (establishing a connection with the technique and the individual characteristics of each GK), or in other hand, 2- cooperation/collaboration and opposition between the GK and groups of defenders and attackers, prevailing distinct activities from other sub-groups adapted to each group.

Collective or team exercises, colaboration drills between the Goalkeeper and the organized defense sistem. This structure should involve a significative amount of players, or even the complete defense sistem. Exercises involving the activities of the Goalkeeper in a game situation during the training session, trough the training of their objectives during the game action, in which all the atheletes report to the equal exercises procedures.

Regarding the organization of specific preparation distributed for diferent moments of occurance, the theoretical references say that, the specific training should be developed in every moments of occurance (Warm Up, Main Part and Final Part).

Torres Tobio (1998) says that, the **Warm Up** must prepare accordingly the GK to the activities trough all the session. Torres Tobio (1998) states that, in the Warm Up each Goalkeeper should function autonomously. Fischer *et al.* (1988) corroborates this idea that, is important an individualization of the Warm Up, according to the characteristics of each GK. All the objectives of the Goalkeeper preparation can be developed in the **Main Part**. In the **Final Part** of the training session, Equisoain (2001) highlights the importance of realizing streaching after the specific training, to prevent muscular shortening, and still to take the opportunity to reflect together about the theoretical issues.

Methods

The sample is composed of eight teams of male young squads, distributed for different age groups (11-18 years) from four clubs that played in the first national division of their age group in season 2006-07. The selection of the clubs was also determined, by geographic reasons – affiliated in Lisbon Handball Association.

The number of units of training considered for this study was three training sessions, which sums twenty-four units of training for each team.

Regarding the duration of the trainings observed in the age groups U-14, U-16 and U-18, all of them with ninety minutes duration, suming two hundred and seventy minutes (four hours and thirty minutes) of trainings for each team and five hundred and forty minutes (nine hours) observed for each age group, in the preparation of the final round of the competition, which ensured a similar frequency of training

In U-12 age group two teams were observed in a different moment of the season (two weeks in the Preparation Period) suming three hundred and ninety minutes (six hours and thirty minutes) of observation.

Given this difference between the U-12 age group and the others, regarding the volume of training, we compare the relative values, defined by the percentage values.

A questionnaire was applied to specialist of goalkeeper training, to validate a classification of exercises for goalkeepers training depending on the objectives (Specific and General Preparation) and characteristics (Developed Components; Moment of Occurance and Mode of Organization).

Six specialists of goalkeeper training were consulted, including coaches that wrote papers about goalkeepers; current and former National Male and Female Coaches; Assistant Coaches of High Level teams responsible for goalkeeper training, assembling a panel of experts of goalkeeper training.

A questionnaire of specialists for goalkeeper training were used to register their classification to a representative set of thirty five exercises for goalkeeper training, that we register more frequently during the validation and fidelization process of the *Register Form of Observed Training*, and also that, the empiric knowledge show us as representative of the trainings with youngsters. The specialists give a classification depending on their experience and on the theoretical references.

After the goalkeeper specialist classification, we used the *Register Form of Observed Training*, in the choosen trainings of the participant teams of the study, trough the Direct Observation, and carried out simultaneously a Digital Registration for subsequent confirmation of these observed data collected.

The first phase of the data threatment was trough univariate analysis, with frequency verification and calculating the measures of central location and dispersion for each variable, and afterwords, confirming the statistical significance for each comparison: *Kruskal-Wallis* (compare variables considering the overall sample); *Friedman* (compare the same variable between age groups), for a degree of significance equal or inferior to 0,05.

Conclusions

The purpose of this study was to analyse the reality of Handball training, aiming for the preparation of young Goalkeepers. We try to prove the importance dedicated to the training of this specific position and make a characterization of the structure of the Goalkeeper specific training, as to the differences observed in the developed components; as to the training

moments of occurrence and through the different modes of organization, to apply the specific contents in the formation process of the Goalkeeper.

The importance dedicated to the Goalkeeper training in the formation process was confirmed by the observed training time (90,46%) with general and specific activities for the Goalkeeper. The time spent with the specific preparation had a slight predominance relatively to the time occupied with the general preparation of the Goalkeeper. Regarding the different age groups, the Goalkeeper specific preparation had higher values with younger age groups (U-12 and U-14).

Considering the overall sample, the training time dedicated with Goalkeeper specific training activities had predominance of technical preparation (and also a higher percentage of time spent with tactical preparation), was realized in the Main Part of the training sessions and specially through collective modes of organization.

Regarding the characterization of the structure of the Goalkeeper specific training in each observed age group:

- U-12 – this age group developed the technical preparation during more time; presented a higher amount of specific training in the Main Part and adopted more collective modes organization, but rather was the age group that spent less time in individual modes of organization.
- U-14 – this age group presented a higher difference between the technical preparation and the other training components; realized more GK specific training time in the Warm Up and the fewer time with exercises in group organization.
- U-16 – this age group (along with U-14) presented statistical differences between technical preparation and the other training components; show a wider distribution of specific training for three Moments of Occurrence in the training sessions.
- U-18 – this age group occupied less time with specific preparation of the Goalkeeper; presented a higher value of physical preparation and consequently reduced values of technical and tactical preparation; spent more specific training time during the Main Part (after U-12 age group) and the one that used less amount of time with collective modes of organization, and the age group that used more time the group organization.

In short, with the final conclusions it becomes evident, the results of this study show us that, in the observed training sessions realized by young age groups, the Goalkeepers performed training drills of General and Specific Preparation, in every training session.

However, in the characterization of the specific activities of the Goalkeeper is not clear that coaches respect the individualization training principle, because they utilized rather collective modes of organization in the training drills; there were no equivalent distribution of the GK specific exercises in the different moments of occurrence (Warm Up, Main and Final Part), and still an absence of an expanded development and properly supported in all the training components (physical, technical, tactical, psychological and theoretical).

castro.r.joao@gmail.com

DIFFERENCES IN SITUATION EFFICIENCY PARAMETERS BETWEEN TOP MEN AND WOMEN HANDBALL TEAMS

Nikola FORETIĆ¹, Nenad ROGULJ¹, Vatroimir SRHOJ¹, Ante BURGER¹, Kornelija RAKOVIĆ²

University of Split, Faculty of Kinesiology¹, Split – Croatia

University of Mostar, Faculty of Mathematics and Education Sciences², Mostar – BIH

SUMMARY

The objective of this study was to determine and explain differences in the standard parameters of situational efficiency between top male and female handball teams. It can be concluded that there are significant differences in some of the standard situational efficiency parameters between top male and female handball teams. The differences are primarily related to the frequency and successfulness of indicators and not on their performance efficiency.

***Keywords:** differences, men, situational efficiency, top handball, women*

INTRODUCTION

The structure of parameters applied in competition activities in contemporary sports is the basis for comparative analysis of the quality of sportspersons and teams, which is equally important for rational planning and programming of training process. Therefore we emphasize the importance of precise profiling of individual structure of situation efficiency indicator of a player and/or entire team. Besides, it is essential for expert coaches and scientists to evaluate the situation efficiency indicators and real players' quality (Foretić et al. 2011).

Handball, as well as other team sports using ball, requires an analysis which would evaluate competition success on the basis of variables of situation efficiency indicators within specific game phases. The latter is determined by the level of success of task completion that each player is assigned with, depending on his/her role and position and the team role within the framework of tactics applied (Foretić i sur 2011).

Relevant researches in the field undertaken so far have treated efficiency in relation to the player's position (Gruić et al. 2006, Ohnjec et al. 2008), the efficiency in relation to shooting zones (Pokrajac 2008, Rogulj 2000), and the efficiency relative to different shooting styles (Delija 1994, Vuleta et al 2003). The differences between shooting frequency and success in relation to the team success have also been researched (Apitzs et al 1997, Taborsky 2008), as well as the influence of tactics elements on the success, and the influence of variables of offensive ending on the final game result (Srhoj et al. 2001, Rogulj et al. 2004, Rogulj et al. 2009). However, an insight in contemporary literature shows the deficit of researches which would compare and analyse men and women handball players in sufficient detail.

Given the progress made in contemporary sport evolution, as well as the development trends which we witness, it arises that sex differences determine sport and/or sport discipline specifics (Deaner 2006). While handball, in terms of top sports, is being played by both men

and women by the same rules, there are many differences as far as structure, kinetics and other kinesiology factors. It is foreseeable that sex differences condition the way of game play whose results as well as sex divergence may be followed by the parameters of situation efficiency. The aim of this paper is to establish and explain the differences in standard parameters of situation efficiency between top men and women handball teams.

METHODS

Entity sampling

Sampling was made on the basis of 24 men teams, the participants in the World Cup held in Croatia in 2009 and 24 women teams participating in the World Cup held in France in 2007. Men teams played 9 to 10 matches and women some 6 to 10 matches per competition. Due to unequal number of matches, cumulative statistics and measures have been applied, relative to the number of matches played by a team. The data used for the analysis undertaken in this paper have been taken from the statistics of final actions that International Handball Federation (IHF) publishes on its web site at the end of each Championship.

Variable sampling

The total of manifesting variables consists of 3 groups: frequency of shootings, successful shootings (goals) and realisation percentage (the relation between frequency and realised goals). Within each group there are 6 variables: 6 m line shootings (6m/S), wing position shootings (Wing/S), outer position shootings (9m/S), 7 m shootings (7m/S), shootings from the offense transition (FB/S), shootings after passage (BT/S), 6 m line goals (6m/G), wing position goals (Wing/G), outer position goals out of 9 m line (9m/G), goals from 7 meters (7m/G), goals from the offense transition (FB/G), goals after passage (BT/G), efficiency from 6 m line (6m/%), efficiency from wing positions (Wing/%), efficiency from outer position of 9 m (9m/%), efficiency from 7 m (7m/%), efficiency of goals after offense transition (FB/%) and efficiency of goals after passage (BT/%). Except for the mentioned data, we have also used the data concerning the total number of received goals (GOLGET) and given goals (GOLSCO), complete efficiency of realisation (REAL%), and relative assistance number (ASIST), withdrawals (2MIN) and technical errors (TE) of a team.

Methods of data analysis

Based on the data available, we have calculated basic descriptive statistical parameters: arithmetical middle (AS) and standard deviations (SD). Kolmogorov-Smirnov test has shown normal result division per each variable. For the analysis of differences between the groups we have used one way analysis of variance (ANOVA). The analysis has been undertaken by the means of software package Statistica ver. 7.

RESULTS AND DISCUSSION

In table 1. we have shown the results of analysed variance of standard indicators of situation efficiency by top men and women handball players.

Table 1. Variance analysis of men and women teams efficiency

VARIABLE	MEN X±SD	WOMEN X±SD	F	p
GOLSCO	27,64±3,95	25,57±7,50	1,43	,24
GOLGET	27,76±3,48	26,92±6,02	,35	,56
REAL %	54,92±6,01	52,21±8,34	1,67	,20
6m/G	5,79±1,28	5,63±1,30	,18	,68
6m/S	8,79±1,86	9,54±2,08	1,78	,19
6m/%	66,08±6,14	59,00±6,44	15,22	,00*
Wing/G	3,96±1,19	3,47±1,26	1,93	,17
Wing/S	7,20±1,73	6,91±1,95	,29	,59
Wing/%	54,75±7,07	50,46±11,05	2,57	,12
9m/G	8,69±1,80	7,03±2,09	8,65	,01*
9m/S	21,93±3,57	19,80±3,58	4,25	,04*
9m/%	40,00±6,84	35,92±8,80	3,22	,08
7m/G	2,57±0,59	3,11±0,93	5,75	,02*
7m/S	3,60±0,71	4,28±1,15	6,11	,02*
7m/%	71,21±8,45	72,21±10,81	,13	,72
FB/G	4,97±1,41	5,22±2,43	,18	,67
FB/S	6,68±1,77	7,34±3,38	,71	,40
FB/%	73,29±7,86	70,92±9,16	,93	,34
BT/G	1,67±0,67	2,27±0,91	6,83	,01*
BT/S	2,09±0,77	2,90±1,15	8,11	,01*
BT/%	79,79±9,33	77,00±17,26	,49	,49
ASIST	11,50±2,54	11,31±4,17	,04	,85
TE	14,87±3,91	18,49±3,96	10,10	,00*
2MIN	4,01±1,06	3,49±0,77	3,80	,06

The first three variables (GOLSCO, GOLGET, REAL%) that tell us about summary indicators of efficiency between men and women handball players announce the similarity of final game results, i.e. the number of received and given goals and their realisation efficiency. Superficial observation would lead to the conclusion that men and women handball are identical, which is not by chance. When observing the remaining standards of situation efficiency we may see numerous differences, some of them being at the level of statistical significance.

Statistically significant difference is visible in eight variables: 6m/%, 9m/G, 9m/S, 7m/G, 7m/S, BT/G, BT/S i TE. Given that the aim of this paper is to detect and explain the differences between top men and women handball players, only the above mentioned variables that have shown certain statistical importance will be further discussed.

Handball players have proved to be more efficient during shooting from the position of cruising offence player and the reason for this possibly resides in the closeness of the goal gate during shooting. Namely, it is well known that the speed of shooting is linked to player's strength and as the distance from the goal is shorter, faster is the ball (Grandos et al 2007, Foretić et al 2010). As the distance from the goal gates gets bigger, the speed of ball and consequently the differences in the efficiency levels are smaller. It is obvious that the speed of handball player's ball conditions higher efficiency. Other variables prove the same because they have had higher efficiency than women handball players per all parameters although it was not statistically important.

Results have shown that handball players shoot much more (2,13 more shootings per game) and achieve more goals from outer positions (1,66 more goals per game). This is probably the consequence of faster and stronger shooting by handball players but also due to the game strategy. Contemporary researches have established that the difference between win and loss situation in men handball is conditioned by the efficiency of shooting towards goal from the outer positions (Rogulj 2000, Foretić i sur 2010). Therefore, it is logical that handball players will more often shoot towards goal gates from the outer positions, and consequently achieve better score.

The situation is quite different when shooting from 7 m is analysed. The results indicate that significantly higher number of shootings and consequent higher score by women handball players. Women handball teams shooting from 7m scored on average 0,54 goals more per game than men handball teams. Higher number of 7m shootings is the consequence of game tactics by women handball teams which more often than men teams decide to pass or feign. This happens in the jump zone of goal keeper's area, unruly stoppage of whom is being penalised by 7 m shooting.

When observing the parameters of situation efficiency of shooting after passage it is obvious that much more shootings (0,81) and goals (0,60) from passing is scored by women handball players. Explanation is simple and it is possible to link it with above mentioned phenomena of efficiency of penalty shooting. It is obvious that women handball players prefer passing, when compared to the men handball players' style. Weaker efficiency from outer positions forces them to play the game characterised by feigning, passage and actions close to goal keeper's area.

The results have shown that men handball teams make significantly less errors, i.e. 3,62 technical errors less per game than women teams. This information is not unexpected given that women teams effect more ball passings than men teams with the aim of positioning as close as possible for shooting. A higher number of passings closer to defence players may cause cutting of ball's path, imprecise ball passing, fouls during shooting towards goal gates or other technical errors.

CONCLUSION

Theoretically speaking, this research has opened some possibilities for discussion between men and women handball on the basis of tactics and strategy of the game which is conditioned by the anthropological difference between the sexes, and in this research it is being concretised by the differences in situation efficiency. We'd like to emphasise the differences in the playing style need to be observed in relative and not absolute terms, for it is obvious that morphological-motorical, as well as psycho-sociological structure of sex conditions the style of playing.

We may conclude that there are significant differences in some standard indicators of situation efficiency between top men and women handball teams. However, the differences relate primarily on the frequencz and successfulness of certain elements and not on the frequency of performance. Standard indicators are not the only measure of efficiency of men and women handball players, and the authors' standpoint is that further research and analysis of some other non standard indicators was possible and achieve success in a more quality way – describe the differences between top men and women handball players.

The results of this research need to be supplemented by examining differences in other anthropologigal segments (motorics, anthropometrics, psychological, sociological aspects,...) in order to further highlight the differences between men and women handball. It is possible to apply the above in coaching top handball teams, at which coaches who migrate from women to men handball or vice versa, have to know the specificities that each of the sexes generate in playing handball.

nikolaforetic@hotmail.com

USING DEA TO ASSESS THE EFFICIENCY OF HANDBALL TEAMS

Óscar GUTIERREZ AGUILAR, José Luis RUIZ GOMEZ, Jaime RAMIS CLAVER

University Miguel Hernández, Elche, Spain

ABSTRACT

This article shows how Data Envelopment Analysis (DEA) can be used to identify a model of effective team. Statistical data of the national teams participating in the Men's World Handball Championship held in Sweden in 2011 was analyzed.

The results showed that 9 of the 24 teams were efficient, revealing that each of them reached the efficiency model with a different pattern of game. Likewise, inefficient teams showed their weaknesses, and DEA indicated possible areas for improvement.

Finally, a comparison was made between the classification achieved by each team in the World Championship and the ranking prepared by the coefficient of efficiency obtained complemented with a cross-efficiency evaluation. With few exceptions, both classifications are very similar.

Keywords: Handball, efficiency, Performance, Data Envelopment Analysis.

INTRODUCTION

There are several articles designed to determine which indexes are more representative or which may be more significant for the analysis of tactics. A recurring line of research seeks distinctive performance variables of the winning teams, so they can be compared with the losing teams for efficient game models.

In this sense, different studies have been carried out on team sports such as basketball (Sampaio & Janeira, 2003), football or rugby (Ortega, Villarejo & Palao, 2009). In other cases, the differences between winners and losers has been evaluated taking into account the variable of gender, class or both (Sampaio, Ibáñez & Feu, 2004).

Similarly, in the handball there are several studies that evaluate the efficiency indices based on tactical tactical statistical or modulate these indicators by category studied.

However, analysis of statistics from several teams in a competition or a team in a match can lead to biased conclusions. Teams with different strategies, approaches and typologies produce different tactical indexes (Gruic, Dinko & Dragan, 2006). Therefore, a pre-set pattern of game cannot be imposed on all teams. An evaluation method that respects the game model established by each team is required.

In this context, the DEA analysis is confirmed as a valid methodology, and imposes no importance, or weight range preset on the inputs or the products. And besides, does not impose a specific function of the relationship between inputs and outcomes.

This analysis technique is frequently used to evaluate the efficiency of a producer. The producers are known within the DEA literature as decision units or DMUs, for its acronym (Decision Making Units). The evaluation of a decision unit is done by comparing a particular unit with the performance of similar units that provide the same service.

DEA can compare a DMU directly with a similar or a combination identifying those that require more attention and indicating where improvements can be made. That is, this analysis not only allows teams to asses adapting to his own pattern of game, but also points the tactical aspects that require improvement.

Thanks to these and other advantages, the DEA initiated by Charnes, Cooper and Rhodes (1978) has been increasingly applied in different fields. It should be noted that until 2007 there were more than 4000 research papers in journals and book chapters on this theme.

Applications of DEA in the sport are varied, such as the creation of rankings in competitions where exploiting the flexibility of the DEA to change the weights for each position in the classification to make it more appropriate (Soares de Mello, Angulo-Meza, Lacerda & Biondi, 2009).

Other studies aim to assess the performance in team sports, either to estimate the performance of the team or individual players. DEA has been used for assessing the overall efficiency of a team in a season or of different players taking into account the nature of the game (Cooper, Ruíz & Sirvent, 2009; Fried, Lambrinos & Tyner, 2004).

The aim of this paper was to assess the efficiency of national handball teams in the senior male category by applying the DEA.

METHOD

In order to study, data were obtained from the participating teams in the Men's World Handball Championships 2011 held in Sweden, therefore, the sample analyzed in this article are the 24 teams in the championship. The data used came from official statistics of the International Handball Federation (IHF).

In this study the statistics of goals and shots from different distances, situations and positions for the game has been considered. Likewise, other aspects such as goals from counterattacks, recoveries and blocks were also rated. Specifically, 8 variables have been used in the analysis and are described below: "Gwing" goals achieved from the wing position, "G6m" are the goals scored from 6 meters, "G9m" goals achieved from 9 meters, "G7m" the goals scored from 7 meters, "Gfastb" goals obtained by counterattack, "gbt" goals obtained by breakthrough, "Rec", recoveries made and "Bloc", the blocks made.

The application of DEA to these variables allowed the classification of teams as efficient and inefficient, and to establish the patterns of game used by each team. Thus, knowing the patterns of play of each team and the efficiency level of each of the different variables studied facilitates an analysis of the characteristics of participants of the Men's World Handball Championship of 2011.

The index of relative efficiency provided by the DEA agglutinates into a single value the efficiency data obtained in the different variables. To obtain this index the following formula is applied:

$$I = \omega_1 \times G9m + \omega_2 \times G6m + \omega_3 \times G7m + \omega_4 \times Gwing + \omega_5 \times Gfastb + \omega_6 \times Gbt + \omega_7 \times Rec + \omega_8 \times Bloc.$$

Thus, a team is efficient if and only if, its efficiency ratio is equal to 1, otherwise it is inefficient, and the lower your score is lower efficiency. The DEA benchmarking analysis has been complemented with a cross-efficiency evaluation, which provides a peer-evaluation of the players that makes it possible to rank them.

It is worth emphasizing that DEA allows a complete liberty of choice of weights: if a team is free to choose their pattern of game (and therefore the weights of the different variables) and other teams have a greater efficiency score on those weights, then the statement of inefficiency is reinforced as it is not based on imposing a predetermined model.

The coordination of these reference models allows to study the directions of improvement of inefficient teams, being them a useful tool to improve teams game.

DEVELOPMENT

DEA revealed that 9 teams out of 24 teams participating were efficient (Table 1). In the assessment of each team, DEA respects its characteristics in the sense that these are allowed to choose weights that are team-specific, which means that the relative importance attached to the variables involved may vary from team to team. So the contributions to the efficiency of every aspect of the game for each team were registered.

Table 1. Efficient teams and relative contribution of the game variables analyzed.

	N	G6m	Gwing	G9m	G7m	Gfastb	Gbt	Rec	Bloc	Total
FRANCE	13	11,04%	11,04%	11,04%	13,38%	13,38%	13,38%	13,38%	13,38%	100,00%
DENMARK	9	22,79%	22,79%	22,79%	6,32%	6,32%	6,32%	6,32%	6,32%	100,00%
SPAIN	13	6,32%	14,40%	6,32%	26,99%	6,32%	6,32%	26,99%	6,32%	100,00%
CROATIA	2	5,28%	23,80%	5,28%	24,90%	5,28%	24,90%	5,28%	5,28%	100,00%
ICELAND	5	3,13%	3,13%	3,13%	3,13%	40,61%	3,13%	40,61%	3,13%	100,00%
HUNGARY	0	1,95%	1,95%	1,95%	35,42%	48,64%	1,95%	1,95%	6,18%	100,00%
NORWAY	6	68,03%	1,80%	1,80%	1,80%	1,80%	1,80%	1,80%	21,17%	100,00%
KOREA	0	6,64%	1,18%	1,18%	54,79%	1,18%	32,65%	1,18%	1,18%	100,00%
SLOVAKIA	4	34,46%	8,43%	4,75%	33,39%	4,75%	4,75%	4,75%	4,75%	100,00%

The contributions are the product of the weights obtained and the actual data. The contributions to the efficiency represent the contribution of each factor to the overall efficiency. Therefore, provide information on the importance of each aspect of the game has to evaluate each team.

Thus, the existence of highly specialized teams that achieve efficiency by putting all the weight on a single aspect has been revealed. In contrast, other teams have more balanced patterns in which all the different aspects of the game have a more distributed weight.

Many times the validity of a strategic or tactical approach of a team is based solely on the achievement of the victory, being the winner rated as the best. But this idea should not blind us to assess the efficiency of other participants, as has been shown that there may be other teams that can serve as a model of efficiency.

DEA also incates the number of times each efficient equipment has acted as a reference in the evaluation of other teams. This data shows which teams have played an important role in the analysis of relative efficiency. There are teams that have acted as a reference multiple times, and others not.

DEA shows the directions of improvement for inefficient teams (Table 2) by comparing the real data of each team and their coordinates of efficiency. The directions of improvement, expressed in percentages, facilitates recognize those teams that are almost efficient and those wich should improve many aspects of their game.

Table 2. Directions for improvement of inefficient teams.

	G6m	Gwing	G9m	G7m	Gfastb	Gbt	Rec	Bloc
SWEDEN	40,37%	17,35%	22,83%	47,87%	17,35%	17,35%	17,35%	42,90%
POLAND	4,22%	18,83%	24,74%	12,66%	4,22%	17,15%	4,22%	4,22%
SERBIA	42,76%	9,82%	9,82%	9,82%	82,63%	9,82%	89,11%	32,12%
GERMANY	1,44%	1,44%	1,44%	46,71%	50,75%	14,14%	1,44%	28,77%
ARGENTINA	40,29%	18,24%	88,04%	18,24%	18,24%	18,24%	21,86%	34,05%
EGYPT	35,74%	23,61%	96,99%	34,06%	58,75%	34,30%	23,61%	39,53%
ALGERIA	48,53%	48,53%	48,53%	336,20%	90,39%	48,53%	48,53%	74,15%
JAPAN	66,69%	5,21%	191,49%	129,84%	5,21%	5,21%	37,79%	229,42%
AUSTRIA	0,14%	48,71%	12,65%	29,53%	0,14%	101,51%	31,28%	0,14%
ROMANIA	35,85%	16,31%	16,18%	17,66%	18,22%	67,84%	5,81%	5,81%
TUNISIA	33,45%	33,45%	39,30%	102,06%	91,19%	33,45%	33,45%	33,45%
BRAZIL	1,34%	1,34%	68,12%	1,34%	53,15%	14,31%	9,60%	11,05%
CHILE	50,55%	28,40%	110,76%	135,47%	15,30%	10,09%	10,09%	54,59%
BAHRAIN	96,04%	155,65%	62,75%	40,57%	26,82%	26,82%	26,82%	138,33%
AUSTRALIA	87,42%	176,56%	87,42%	87,42%	161,13%	87,42%	107,65%	152,38%

Note that these directions of improvement have been selected taking into account the pattern of the game of each team and not to copy a fixed model or the game model of another team. The directions of improvement are team-specific.

Finally, a cross-efficiency evaluation was applied in order to obtain a ranking of efficiency. A comparison was made between the classification achieved by each team in the World Championship and this ranking. With few exceptions, both classifications are very similar.

CONCLUSIONS

DEA can be a powerful tool for coaches. Recognize different efficiency models can ease the task of the coach in selecting wich aspects of the game improve. The election of a plausible model of efficiency can lead to greater levels of efficiency, and therefore high levels of performance.

The index of relative efficiency provided by the DEA agglutinates into a single value the efficiency data obtained in the different variables. As stated earlier, DEA imposes no specific pattern of game, respecting the game model defined by each team. Therefore, each team can exploit their strengths in the assessments. For that purpose, patterns of game of inefficient teams are established based on the modeling weights of efficient teams.

DEA can identify directions for improvement. Coaches with information on the strengths and weaknesses of their team can implement development plans that will lead their teams to success.

PROPOSAL FOR COACHES

DEA can be applied in different situations: Late season: To recognize weaknesses and select correctly the players needed to reinforce the team; during the season, to correct the errors and to establish which tactical aspects should be prioritized to improve the team; before a new competition: with an adequate amount of matches in other competitions, DEA can be used to determine the status of the team.

ogutierrez@umh.es

THE TEAM MATCH PERFORMANCE INDICATORS AND THEIR EVALUATION IN HANDBALL

Ján HIANIK

The Faculty of Physical Education and Sport, Comenius University Bratislava Slovakia

ABSTRACT

The aim of the paper was to find out the connection between the success in team match performance indicators and the final match result. A remarkable connection to the match result has been noticed between the unsuccessful realization of the field players' indicators and successful realization of goalkeeper's indicators, especially in winning matches.

Keywords: handball, assessment of performance, offensive phase of game, defensive phase of game, goalkeeper

INTRODUCTION

The basic criterion of a team's sport performance is its top performance in a particular sport. Therefore, crucial performance of a handball team is that which is achieved in a regular match. We call it a team's playing performance in a match. Based on this, it is imperative for a coach to thoroughly analyze a team's playing performance as it shows the results of his training efforts.

A team's performance in sports games, specifically its identification and evaluation has been a long-term matter in the world of sports. The team is being monitored by their activity, which can have a substantial influence on the course of a match and especially on its final result. The evaluation of a team's playing performance is based on a method of evaluating crucial cases of successful and unsuccessful game situations. A crucial case (indicators) is considered as one that markedly enables or prevents reaching an aim in the match. Even though a crucial case in handball is evaluated by a highly qualified specialist, it should be able to be monitored relatively easily and defined clearly.

The issue of evaluating a team's playing performance in handball is included in the works of many authors: Slovík (1979), Táborský (1989), Langhof (1996), Zaťková, Hianik (1995), Hianik (2004), Hianik (2009).

Hianik (2004, 2009) monitored the relation between successful offensive and defensive game activity and the final match result. In his works a criterion for success was stated as depending upon either a successful or unsuccessful solution of offensive and defensive game action. One of Hianik's findings (2004, 2009) was a higher partial influence of unsuccessful offensive and defensive game actions for the final match result.

THE OBJECTIVE

The objective of this work is to find the relationship between the success of evaluation indicators of the playing performance of men's handball team and the final match result.

WORKING HYPOTHESIS

We expect greater impact of unsuccessful realization of the performance monitoring indicators on the final match result.

METHODS

To obtain the results of the work we used a retrospective research on ex post facto. The research was conducted in natural conditions in men's team sports training. Viewed team played top

competition in Slovakia. The observation we made during the three years of competition. We analyzed 108 handball matches. Team SKP Bratislava won 39 games, drew 7 and 62 lost. Assessment game team performances, was analyzed by the video. We used a computer program "Assessment game performance in team handball" to evaluate these results. The program was created in Microsoft Excel spreadsheet. Every match was evaluated by the same pair of experts: coach and his assistant.

To observe the match performance indicators we concentrated on “techniques of critical incident” this theory elaborated Flanagan (1954). Match performance in team handball is simply expressed by winning the match, a draw and lose. However, it is expressing its relative value. It is different to play against strong opponents and weaker ones. In handball is therefore more advantageous to create a sub-match performance, so-called team match performance indicators (critical case) which have decisive importance for the match performance team.

Indicators the team match performance in handball

Offensive phase of game

The team’s match performance in offensive phase of the game we followed through 22 indicators, including 12 positive and 10 negative (Table 1).

Table 1 Indicators in the offensive phase of game and their quantification

Offensive phase of game	Positive point	Negative point
Back area shooting	4	-2
Wing area shooting	4	-2
Pivot area shooting	4	-2
Breakthroughs shooting	4	-3
Fast Breaks shooting	4	-3
7 metre Shots	4	-3
Assistance	3	-
Received 7m-Fouls	3	-
Rebound in attack	3	-
Turnover	-	-3
Attack Interruption	2	-1
2 Minute Suspensions: opponent-own	3	-3
Disqualified: opponent-own	4	-4

Defensive phase of game

The team’s match performance in defensive phase of the game we followed through 17 indicators, including 9 positive and 8 negative (Table 2).

Table 2 Indicators in the defensive phase of game and their quantification

Defensive phase of game	Positive point	Negative point
Individual improvement activities defending	2	-4
Basic attack combinations defending	3	-3
Special attack combinations defending	4	-2
Blocked Shots	3	-1
Rebound defending	3	-3
Steal Ball	4	x
7 metre foul	x	-3
2 Minute Suspensions: opponent-own	3	-3
Disqualified: opponent-own	4	-4
Unenforced opponent’s turnover	1	x

Match performance of goalkeeper

Match performance of goalkeeper we followed through 27 indicators, including 14 positive and 13 negative (Table 3).

Table 3 Indicators of the match performance of goalkeeper in the game and their quantification

Goalkeeper	Positive point	Negative point
7 metre Penalty Shots	4	-1
Fast Breaks Shots	4	-1
Breakthroughs Shots	4	-1
7-9 metre Shots	3	-2
9 metre Shots	2	-3
Wing Shots	3	-2
Pivot Shots	3	-2
Make Fast Breaks	1	-1
Assistance	3	x
Steal Ball	4	x
Turnover	x	-3
Goalkeeper defending in Field	4	-3
Goalkeeper Shooting	4	-2
2 Minute Suspensions: opponent-own	3	-3
Disqualified: opponent-own	4	-4

The criterion of success indicators have been successful for us (+) or unsuccessful (-) solution of game situations.

The processing and evaluation of the work we used the following methods:

frequency analysis of observed match performance indicators (contingency tables) and testing the level of association between the success of match performance indicators to the final match result [chi - square (X^2)] in tabular and graphical representation,

- with statistically significant results, we determined the proportion of the total value of X^2 ,
- we evaluated the significance of differences at 5% and 1% level of statistical significance.

RESULTS

We watched the handball match performance of teams of men in the top league in Slovakia in three competition seasons. In total we recorded 30.037 indicators including the offensive phase of the game was 12.129, in the defensive phase of the game 12.653, in the match performance of goalkeepers 5.255.

Table 4 Relationship between success indicators match performance team and the final match result.

<i>Indicator</i>	<i>Number</i>	X^2		
		<i>Total</i>	<i>Unsuccessful</i>	<i>Successful</i>
Offensive phase of game	12.129	108,15**	60.17	47.98
Defensive phase of game	12.653	81,74**	51.59	30.15
Goalkeeper	5.255	42,14**	17.66	24.48

The relation of team match performance indicators in offensive phase of game on the final match result

In the offensive phase of the game the final match result was significantly ($p < 0.01$) depended on the indicators of the reference of the observed team (Table 5). We note the superiority of successful solutions for the indicators (55.6%). The highest proportion was in winning matches (62%). The highest impact on the final result of the match we registered in unsuccessful realization of performance monitoring indicators ($X^2 = 60.17$).

Table 5 The relation of team match performance indicators in offensive phase of game on the final match result

%	Unsuccessful	Successful	Number	X^2	Unsuccessful	Successful	Total
Lose	48%	52%	7.038	Lose	21.92	17.48	39.4
Draw	46%	54%	746	Draw	0.25	0.2	0.45
Win	38%	62%	4.345	Win	38	30.3	68.3
Number	5381	6748	12.129	Total	60.17	47.98	108.15

The relation of team match performance indicators in defensive phase of game on the final match result

In the defensive phase of the game the final match result was significantly ($p < 0.01$) depended on the indicators of the reference observed team (Table 6). In the defence phase we have see up to 63% of successful solution in the indicators. The highest proportion was in winning matches (68%). The highest impact on the final result of the match we registered in unsuccessful realization of performance monitoring indicators ($X^2 = 51.52$).

Table 6 The relation of team match performance indicators in defensive phase of game on the final match result

%	Unsuccessful	Successful	Number	X^2	Unsuccessful	Successful	Total
Lose	40%	60%	7.117	Lose	17.23	10.01	27.24
Draw	37%	63%	833	Draw	8.25	4.83	13.08
Win	32%	68%	4.703	Win	26.11	15.31	41.42
Number	4676	7977	12.653	Total	51.59	30.15	81.74

The relation of match performance indicators of goalkeeper on the final match result

In the match performance of goalkeeper the final match result was significantly ($p < 0.01$) depended on monitored indicators of the goalkeepers (Table 7). Relationship of success of the match performance to the final result of the goalkeepers was different comparing field players. We note the predominance of the unsuccessful solution in monitored indicators (58%). In the defence phase we have see up to 63% of successful solution in the indicators. The highest influence on the final result of the match we registered in successful realization of the performance monitoring indicators ($X^2 = 24.48$).

Table 7 The relation of match performance indicators of goalkeeper on the final match result

%	Unsuccessful	Successful	Number	X^2	Unsuccessful	Successful	Total
Lose	62%	38%	3.091	Lose	7.27	10.07	17.34
Draw	52%	48%	342	Draw	1.95	2.71	4.66
Win	53%	47%	1.822	Win	8.44	11.7	20.14
Number	3.053	2.202	5.255	Total	17.66	24.48	42.14

CONCLUSION

Summary

The match performance of field players (offensive and defensive phase of the game), we have seen significant relationship unsuccessful realization of monitored performance indicators on the final match result. The match performance indicators of goalkeeper confirmed the significant relationship of successful solutions in the monitored indicators on the final match result.

Based on the findings of the significant relationship with indicators of successful realisations in team goalkeepers' comparing them on the final match result we considered the hypothesis to be unconfirmed.

Importance for practice

The paper solved the problem of evaluation of the match performance in men's top handball teams. Based on the results of the work we recommend that diagnoses of the unsuccessful realization of performance indicators in the field players and successful solutions in match performance indicators according to goalkeepers. When planning the content of their sports training it is necessary to give an adequate space and thereby reducing the frequency of their occurrence in the matches.

hianik@fsport.uniba.sk

ANALYSIS OF EVALUATIVE METHODS OF THE EXTERNAL LOAD ON PLAYERS DURING A MATCH IN SPORT GAMES: REVIEW ARTICLE.

Karel HULKA & Jan BELKA

Faculty of physical Culture, Palacky University Olomouc, Czech republic

The goal of this paper is to analyse and afterwards to describe the methods which evaluate the external load (distance and velocity) on players during a match by the means of modern technology equipment available on the trade. Presently, the research of load on players during matches (analysis of external loading) is based on GPS technology, systems based on ultra-sound and infra-red waves and airwaves, systems based on movement monitoring via video (Tracking system).

Keywords: load, analysis, match, sport game.

INTRODUCTION

The last two decades took place the progressive changes in the game performance approach. The increase of game performance depends on training session quality which comes out from match performance simulation in sports games. That is why the most basic instrument is the analysis of external and internal load during a match which enables to apply match intensity to practices.

According to Rodriguez-Alonzo et al. (2003) and Thomassen a Skille (2000) is very important to combine evaluative methods to comprehensive description of external and internal load during the match. Except for heart rate monitoring (internal load) the present top clubs use the distance and velocity analysis systems (external load) on that account. We can describe the match performance by distance, velocity, mean and relative heart rate, work/rest ratio and agility parameters (starts, stops, accelerations, decelerations, etc.), which we consider to be essential to intermittent performance description.

Measured (Burgess et al., 2006; Carling et al., 2008; DiSalvo et al., 2007; Erčulj et al., 2008; Rudkin et al., 2008) data from the match can be used by coach

- to detailed description of match performance of his players as a starting point for match performance simulation in the practice to maximize the loading specificity,
- to get basic information for creating of pre-season conditioning plans,
- to individualize the loading in the practice,
- to get feedback about performance of his players during the match.

The goal of this paper was to find strengths and weaknesses of modern evaluative methods of external loading on player's during the match or training process.

RESULTS AND DISCUSSION

Modern cartographical methods

Modern cartographical methods connected to old ones, which were based on spotting player's movement trajectory during the match to the map of the court prepared in advance. The distance was calculated by using Cartesian coordinate system. SportSec Company (Australia) developed modern cartographical system TrakPerformance® (<http://www.sportstec.com/>). TrakPerformance® utilized the electronic pen and tablet and worked on the same principles as old ones.

Strengths. Hartwig et al. (2007) presented relatively good validity of distance measurement $r=.98$. In comparison with further methods this system the price was fairly low (€1 750 for software). The third strength was the measurement does not affect the performance of players during the match.

Weaknesses. Duration of collecting data was the biggest weakness because one observer could collect data about one player directly during the match.

Methods based on ultrasound, radio and infrared vibration

The players had fixed a receiver of vibration on their body and the transmitters of vibration with known positions were placed around the court. Methods were based on tracking the players' distance by vibration from transmitters. Subsequently the distance and velocity were calculated by principle of triangulation. Current systems and studies are presented in Table 1.

Table 1. Methods based on ultrasound, radio and infrared vibration

Company/system	vibration	Used of	Web
Inmotio (NED)/ 3D Soccer	Radio	Soccer	http://www.inmotio.eu/ http://www.abatec-ag.com/
Digital sports information (UK)/ Trakus	Radio	Ice hockey	http://digitalsportsinformation.com/ http://www.trakus.com/

Strengths. Reinhold et al. (2008) presented very high accuracy of Inmotio-3D Soccer® (radio vibration) ± 5 centimetres. The possibility to track players online during the match was second strength.

Weaknesses. The necessity to wear the receiver during the match which could impact the match performance was the problem of this methods.

Methods based on GPS technology

Methods used GPS (Global Positioning System) which attend to position and time determination of units on the Earth. Method required players to fix GPS receivers on their bodies. According to Carling et al. (2008) and Townshend et al. (2008) GPS receiver was added by 3D pedometers and 3D accelerometers for higher accuracy. Current systems and studies are presented in Table 2.

Table 2. Methods based on GPS technology

Company/system	Used of	Web
GPSports (AUS) / SPI10	Cricket (Hill-Haas et al., 2009)	http://gpsports.com
	Soccer (Barbero-Alvarez et al., 2009)	
	Rugby (Hartwig et al., 2008)	
	Australian football (Edgecomb et al., 2006)	
CAPTAIN, CPA, UWIC, Cardiff (UK) (Computerised All-Purpose Time-motion Analysis Intergated)	Cricket (Rudkin et al., 2008)	
Catapult Innovations (AUS)/MinimaxX	Beach soccer (Castellano et al., 2010)	http://www.catapultinnovations.com.au
Real Track Football	Fotbal (Pino et al., 2007)	http://www.realtrackfutbol.com
Citech research Pty Ltd / Biotrainer		http://www.citechholdings.com/index.html

Strengths. Edgecomb et al. (2006) published the distance measurement validity $r=.998$. Barbero-Alvarez et al. (2010) presented the test-retest reliability $r=.94$. According to Hill-Haas et al. (2009) the error of distance measurement was 3.6% with movement velocity to seven kilometres per hour and 11.2% with movement velocity to fourteen kilometres per hour.

Weaknesses. The necessity to wear the receiver during the match which could impact the match performance was the problem of this method. In addition GPS signal had problems with sports in the gym.

Methods based on video tracking systems

Methods used the digitalized video from two to several cameras, for example Prozone® needed from eight to ten cameras and Tracab® even eighteen cameras for one soccer court. Current systems and studies are presented in Table 2.

The match analysis had four phases:

- taking an record a his digitalization,
- the record processing by removing of noise and increasing of contrast,
- segmentation – players identification by automatic tracking or manually, raw pixel data were the result of segmentation,
- data interpretation – conversion of raw pixel data to distance and velocity of players.

Table 3. Systems and stuides based on video tracking systems

Company/system	Used of	Internetový odkaz
ProZone (UK)	Fotbal (DiSalvo et al., 2006)	http://www.prozonesports.com/index.html
Sports Universal (Amisco)	Fotbal (DiSalvo et al., 2007)	
SportsCode v8; Sportstec	Fotbal	http://www.sportstec.com/Products_Sportscode.htm
Digital Soccer	Fotbal	
ORAD	Všechny typy	http://www.orad.tv
Tracab	Soccer	http://www.tracab.com/
SAGIT (SLO)	Handball (Perš et al., 2000; Šibila et al., 2004)	http://vision.fe.uni-lj.si/index.html
	Basketball (Erčulj et al., 2008)	
Feedback football, Feedback Cricket	Soccer, cricket	http://www.feedbacksport.com/
DVideo	Soccer (Barros et al., 2007)	
ASPOGAMO Technology	Soccer (Gedikli et al., 2009)	http://www9.cs.tum.edu/projects/aspogamo/

Strengths. The measurement does not affect the performance of players during the match. The possibility to track players online during the match was second strength. High reliability was a natural thing, DiSalvo et al. (2007) presented $r=0.960-0.999$.

Weaknesses. Still not completely solved problems were the cameras calibration and occlusions, that implies places, where the trajectories of players were overlapped each other (Settervall, 2003; Townshend et al., 2008). Next problem was the price of system. According to Settervall (2003) the price is £ 100 000 for system installation. In addition the companies communicated with national federations only.

CONCLUSIONS

We found out high number of evaluative methods of external loading. We could divide it to commercial and non-commercial methods. Non-commercial methods were interesting for our future research but we did not found suitable one for us. We determined to construct a new system on the base of performed S-W analysis and following requirements:

- high accuracy, reliability and objectivity,
- non-affecting the performance of players during the match,
- wide usage of raw data for good interpretation,
- data collection and evaluation as short as possible,
- affordable for the research.

karel.hulka@upol.cz

QUANTIFICATION OF SHOOTING PLAY POSITION AND SHOOTING COURSE FROM PICTORIAL HANDBALL MATCH STATISTICS REPORT

Shiro ICHIMURA¹, Issei OGASAWARA², Yoshikuni NAKATA³,
Takayoshi INAFUKU⁴, Shintaro SAITO⁵, Manabu TODOROKI⁶, Shuji TAMURA⁷,
Tetsushi MORIGUCHI⁸, Mamoru TANAKA⁹

¹Tokyo University of Science, Chiba, JAPAN 278-8510; ²Mukogawa University; ³Meio University; ⁴Sendai University; ⁵Daido University; ⁶Fukushima high school; ⁷Tokai University; ⁸Kagoshima University; ⁹Fukuoka University

Summary

The purpose of this study was to analyze shooting play position and shooting course using quantified data pertaining to the results of handball games played by the teams of China, Japan, South Korea and Norway and to determine whether there were the differences in the shooting play. We demonstrated that shooting play position and shooting course could be quantified using angular data. The quantified data clarified the differences of the angles of shooting among the teams during failed shots.

Keywords: notational analysis, shooting play position, shooting course

Introduction

Recent studies have used notational analysis to analyze performance in ball sports. In handball, the number of scored goals^{1, 2, 3} and the distribution of successful shooting play spaces^{4, 5, 6} have been studied. To the authors' knowledge, however, there are no published reports in which shooting play position and shooting course were quantified. In this study, we propose a means for the quantification of shooting play position and shooting course using the 2-dimensional direct linear transformation (DLT) method with data obtained from Pictorial Handball Match Statistics reports, which are published after matches by the International Handball Federation⁷. We also determined whether there were differences in shooting play using quantified data from the results of the handball games played by China (CHN), Japan (JPN), South Korea (KOR) and Norway (NOR).

Methods

A total of 1374 shooting plays, from 4 teams in 34 games during the 17th Women's Junior Handball World Championship, 2010 were analyzed. The x and y coordinates of the shooting play position and of the location from which the ball was shot toward the goal mouth were determined using Pictorial Handball Match Statistics reports. The angle between the left and right goalposts at the time of the shooting play and the angle of the shooting course were calculated using these data, which were then analyzed by the 2-dimensional DLT method. We also recorded the results of the shooting play (scored goal or failed shot). The shooting play spaces were classified into the following positions: left 6m shooting space (L6M), center 6m shooting space (C6M), right 6m shooting space (R6M), left backcourt shooting space (L9M), center backcourt shooting space (C9M), right backcourt shooting space (R9M), left wing shooting space (LW), and right wing shooting space (RW) using the derived x and y coordinates of the shooting play position (Table 1).

Table 1 Criteria for the classification of shooting space

L6M	left goal area line shots - y axis is less than 12m and the angle between left and right goal posts is more than 15 degrees.
C6M	center goal area line shots - y axis is from 8m to 12m.
R6M	right goal area line shots - y axis is more than 12m and the angle between left and right goal posts is more than 15 degrees.
L9M	failed shots from left backcourt positions - y axis is less than 12m.
C9M	failed shots from center backcourt positions - y axis is from 8m to 12m.
R9M	failed shots from right backcourt positions - y axis is more than 12m.
LW	left wing shots - the angle between left and right goal post is less than 15 degrees.
RW	right wing shots - the angle between left and right goal post is less than 15 degrees.

Calculation of the angle between left and right goalposts at the shooting play position and the angle of shooting course

The x and y coordinates of the left goalpost, the right goalpost, the location of shot the ball toward goal mouth, and the shooting play position were defined as A, B, C, and D, respectively. From A, B, and D points, the angle between left and right goalposts at the shooting play position were calculated using the formula of inner product. The equation that was used is as follows:

$$\cos\theta = \frac{ax \times bx + ay \times by}{\sqrt{(ax^2 + ay^2)(bx^2 + by^2)}} \dots (1)$$

The vector of edge DA and edge DB were defined as a and b, respectively. The calculated $\cos\theta$ was converted to θ using inverse trigonometric function (\cos^{-1}).

The angle of shooting course was calculated from the points of A, C, and D. Next, the difference between the angle of shooting course and half of the angle between the left and right goalposts at the shooting play position was calculated. The equation is as follows:

$$\cos\theta = \frac{ax \times cx + ay \times cy}{\sqrt{(ax^2 + ay^2)(cx^2 + cy^2)}} \dots (2)$$

$$\cos\theta = (2) - (1) / 2 \dots (3)$$

The vector of edge DA and edge DC were defined as a and c, respectively. The calculated $\cos\theta$ was converted to θ using inverse trigonometric function (\cos^{-1}). Here, θ , was the angle of the shooting course was from center of goal.

Statistics

Descriptive data were presented as the mean and SD. Two-way analysis of variance (ANOVA) with post hoc comparisons was used to assess the differences of the angle between left and right goalposts at the shooting play position and the angle of shooting course among each team and among the results of shooting plays using the calculated variables. The dispersion of variables on the angle between the left and right goalposts at the shooting play position and the angle of the shooting course were determined using the Bartlett test. Linear correlation analysis was used to assess the relationship between the angle between left and right goalposts at the shooting play position and the angle of the shooting course. Analysis of covariance (ANCOVA) was performed to test the difference between scored goals and failed shots in terms of a dependent variable adjusted by an independent variable. Statistical significance was set at $P < 0.05$.

Results

Table 2 shows the total number of the scored goals, failed shots, and efficiency from the different playing spaces (left, center, and right and 6m, 9m and wing). The total number of failed shots and scored goals was similar among the teams. However, shooting efficiency tended to be greater in NOR and KOR than in CHN and JPN.

The angle between left and right goalposts at different shooting play spaces

The angle between the left and right goalposts was significantly smaller in NOR than in other teams at C6M and C9M (Table 3). The angle between the left and right goalposts in NOR at L6M and R6M tended to be larger than in other teams. The coefficient of variation (CV) was significant between scored goals and failed shots in all shooting play spaces. In comparison to other teams, the CV at C9M and L6M was smaller in NOR (Table 3).

The angle of shooting course at different shooting play spaces

Table 3 Average and coefficient of variation of the angle between left and right goalposts at different shooting play spaces

		average				coefficient of variation				
		CHN	JPN	KOR	NOR	CHN	JPN	KOR	NOR	F value
L6M	failed shot	16.6 ± 2.6	15.7 ± 1.2 n	15.6 ± 0.4 n	17.3 ± 1.1	15.8	7.6	2.8	6.3	7.04
	scored goal	15.1 ± 3.9 k, n	16 ± 1.3 n	17 ± 1.7	17.9 ± 1.3	25.8	8.3	9.7	7.4	11.62
C6M	failed shot	23.9 ± 1.3 n	22.6 ± 0.9 k, n	23.8 ± 1.2 n	19.2 ± 0.9	5.3	4.2	5.1	4.6	6.03
	scored goal	24.1 ± 1.5 n	23 ± 1.4 k, n	24 ± 1.3 n	19.5 ± 0.8	6.4	6.2	5.4	4.3	
R6M	failed shot	14.8 ± 3.5 n	15.5 ± 1.4 n	16.5 ± 1.8	17.6 ± 1.4	23.3*	8.7	10.9	7.9	4.89
	scored goal	17 ± 1.5	16 ± 1.1 n	16.8 ± 1.3 n	18 ± 1.4	8.8	7.2	7.5	8	
L9M	failed shot	14.2 ± 2.2	14.3 ± 2.1	14.4 ± 2.7	14.2 ± 2	15.8	14.4	18.7	14.2	
	scored goal	15.8 ± 2.4	16.7 ± 1.6	15.4 ± 2.2	16.3 ± 2.3	14.9	9.4	14.3	14.3	
C9M	failed shot	16.2 ± 2.2 n	15.9 ± 1.7 n	15.5 ± 1.6	14.6 ± 1.3	13.4	11	10.2	9.3	2.57
	scored goal	17.3 ± 2 j, n	16.1 ± 1.3 n	16.8 ± 1.8 n	14.8 ± 1.4	11.3	8.3	10.6	9.7	
R9M	failed shot	15.4 ± 2	14.4 ± 2.4	13.5 ± 2*	15 ± 2	13.3	16.6	14.7	13.5	
	scored goal	16.6 ± 2.9 k	15.9 ± 2.1	16.3 ± 2.2 n	15.6 ± 2.4	17.4	13.5	13.4	15.4	
LW	failed shot	10.4 ± 1.7	11.3 ± 2.5	11.8 ± 1.9	10.3 ± 2.7	16	21.9	15.9	26.6	
	scored goal	11.7 ± 2.2	10.3 ± 2.4	11.1 ± 2.2	10.2 ± 2.6	18.9	23.8	19.9	25.8	
RW	failed shot	11.4 ± 2.3	10.6 ± 1.7	10.9 ± 2.2	12.1 ± 2.1	20.6	15.9	20.5	17.2	
	scored goal	11.4 ± 1.7	11 ± 2.4	11.1 ± 2.6	11.1 ± 2.9	14.9	22.1	23.2	25.9	

n: vs. NOR, *j*: vs. JPN, *k*: vs. KOR, *: vs. scored goal, *p*<0.05.

Table 4 shows the angle of the shooting course from the center of the goal at different shooting play spaces and the shooting results. Regarding shooting results, the angles of shooting course at C6M, R6M, and C9M in CHN and at L6M, R6M, L9M, C9M, R9M, RW in JPN and at shooting play spaces excluding LW in KOR were larger in scored goals than in the failed shots. In contrast, the angle of shooting course in NOR did not significantly affect results in any of the shooting play spaces. The CV at all shooting play spaces tended to be larger in failed shots than in scored goals. In JPN, the CV at shooting play spaces tended to be larger than in other teams and the CV at L9M, C9M, and R9M in NOR tended to be smaller than in other teams during failed shots.

Table 2 Number and efficiency of shot

		CHN	JPN	KOR	NOR
L6M	failed shot	1.4	2.1	0.8	1.1
	scored goal	2.0	2.9	2.2	3.9
	shooting efficiency	58.3	57.1	73.3	78.0
C6M	failed shot	1.7	1.1	1.6	2.2
	scored goal	4.7	2.7	3.2	5.9
	shooting efficiency	73.3	70.4	66.7	72.8
R6M	failed shot	1.6	2.1	1.1	1.5
	scored goal	1.9	2.7	2.1	3.3
	shooting efficiency	54.2	55.9	65.6	68.8
L9M	failed shot	4.0	2.7	2.8	2.1
	scored goal	2.3	2.9	2.6	3.7
	shooting efficiency	36.4	51.3	48.1	63.8
C9M	failed shot	3.7	5.7	3.1	4.3
	scored goal	2.0	2.0	4.5	4.8
	shooting efficiency	35.0	25.9	59.2	52.7
R9M	failed shot	2.1	2.9	1.8	3.5
	scored goal	1.7	4.0	3.2	3.5
	shooting efficiency	44.4	58.3	64.0	50.0
LW	failed shot	0.7	3.0	1.4	1.2
	scored goal	1.7	2.0	2.3	2.6
	shooting efficiency	70.6	40.0	62.2	68.4
RW	failed shot	1.4	2.1	1.8	0.8
	scored goal	1.6	2.1	2.7	1.4
	shooting efficiency	52.4	50.0	60.0	63.6

Table 4 Average and coefficient of variation of the angle of shooting course at different shooting play spaces

		average				coefficient of variation				
		CHN	JPN	KOR	NOR	CHN	JPN	KOR	NOR	F value
L6M	failed shot	5.1 ± 2.2	4 ± 2*	3.9 ± 3.3*	6.5 ± 2.3	43.1*	50.8	85.3*	35.4	
	scored goal	5.9 ± 2.3	6.1 ± 2.2	6.4 ± 1.4	7.2 ± 3.1	39	35.3	21.3	43.1	
C6M	failed shot	6.3 ± 2.6*	7.8 ± 4.7	6.9 ± 3.5*	6.8 ± 3.2	41.5	59.9	50.8*	47.7*	
	scored goal	9.3 ± 1.9	8.8 ± 3.2	9.3 ± 1.7	7.4 ± 1.9	20.4	35.6	18.4	25.8	
R6M	failed shot	5 ± 1.6*	3.6 ± 2.4*	4.4 ± 2.7*	6.7 ± 3.3	31.7	64.9	62.2	49.6*	
	scored goal	6.7 ± 1	6.2 ± 2	6.4 ± 1.6	7.5 ± 1.4	14.2	32	24.3	18.2	
L9M	failed shot	5.2 ± 1.4	3.7 ± 2.5*	4.6 ± 2.5*	5.9 ± 2.5	25.8	67.7*	53.7*	43.3	3.85
	scored goal	6.1 ± 1.8	7 ± 1.3	5.9 ± 1.6	6.6 ± 2.1	29.4	18.2	27.4	31.5	
C9M	failed shot	5 ± 2.4*	4.4 ± 3.2*	4.9 ± 3.2*	5.4 ± 1.8	47	73*	66*	33.1	5.71
	scored goal	7 ± 1.3	6.1 ± 2.1	6.6 ± 1.7	6 ± 1.4	19.1	34.1	26.2	22.7	
R9M	failed shot	6 ± 2.6	4.1 ± 2.6*	4.6 ± 2.4*	6 ± 2.4	43.3*	62.5	52.1*	39.6	
	scored goal	6.4 ± 1.4	6 ± 1.9	6.2 ± 1.7	6.1 ± 1.8	21.8	32.3	26.1	29.4	
LW	failed shot	3.5 ± 2	4.1 ± 2.5	3.4 ± 1.4	4 ± 1.7	57*	61.5*	41.3*	42.5*	2.80
	scored goal	4.9 ± 0.9	4.2 ± 1.1	4.1 ± 1.5	4.2 ± 1.2	18	26.6	36.2	28.8	
RW	failed shot	3.7 ± 1.5	2.6 ± 1.9*	3 ± 1.5*	3.7 ± 2.2	41.3	75.9*	49.1	59.4	2.74
	scored goal	4.5 ± 1	5 ± 1.1	4.3 ± 1.5	4.2 ± 1.3	22.4	22.2	36.2	30.1	

n: vs. NOR, j: vs. JPN, k: vs. KOR, *: vs. scored goal, p<0.05.

The relationship the angle between left and right goalposts and the angle of shooting course

Figure 1 demonstrates the relationship between the angle between the left and right goalposts and the angle of shooting course at different shooting play spaces. The slope of the angle between left and right goalposts against the angle of the shooting course during scored goals were 0.15, -0.63, -0.05, and -0.60 in CHN, JPN, KOR, and NOR, respectively. The slope of the angle between left and right goalposts against the angle of shooting course in CHN, JPN, KOR, and NOR were -1.66, -0.41, -1.09, and -0.40, respectively. There were no significant differences among them during scored goals and failed shots. On the other hand, the slope of the angle between left and right goalposts against the angle of shooting course in CHN and KOR was significantly smaller in failed shots than in scored goals.

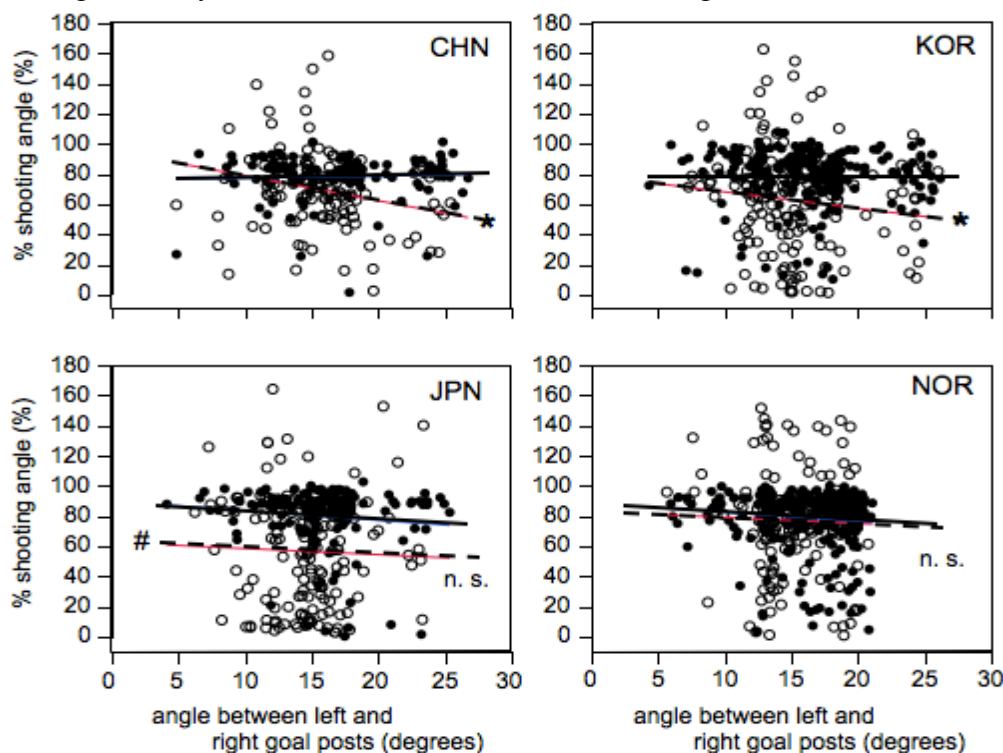

Figure 1 Relationship the angle between left and right goalposts and the angle of shooting course
* P<0.05 difference in slope between shooting results, # p<0.05 difference in intercept between shooting results

Discussion

We proposed that the shooting play position and shooting course were quantifiable as the angle between left and right goalposts and the angle of the shooting course. The quantitative data clarified that there were differences among CHN, JPN, KOR and NOR in the angle of shooting course during failed shots.

There were no differences between shooting results in the average and the CV of the angle between left and right goalposts from each shooting play space. Thus, it was thought that the shooting position in each shooting play space did not affect the shooting results. The averages of the angle between left and right goalposts in NOR were larger than in other teams at L6M and R6M and smaller than in other teams at C6M and C9M. The CVs of the angles between the goal posts at L6M, C6M, R6M and C9M, were also smaller in NOR than in other teams. In NOR, these results demonstrated that the shooting play at center playing space performed at the outside space and that at left and right playing spaces performed at the inside space, compared to other teams. In addition, compared to other teams, NOR showed less variation in shooting positions from the shooting play spaces.

The angle of shooting course during scored goals was larger than that during failed shots for most shooting play spaces. The CVs during scored goals were smaller than that during failed shots for most shooting play spaces (Table 2). Additionally, the shooting course of scored goals was often found to be near the goalposts (Figure 1). We identified that a high precision shooting course was important for scoring goals. In NOR, there were no significant differences in the angle of shooting course between shooting results and the differences of CVs of the angle of shooting course between shooting results were smaller than in other teams. With the exception of the wing shot, the angle of shooting course during failed shots was larger in NOR than in others. NOR had a good performance on the shooting play compared to others if we assume that the shooting around goalpost is high precision shooting play. Furthermore, for NOR, the CVs during failed shots were significantly smaller from L9M and C9M than from other spaces. These data show that NOR was involved in more high precision shooting play in the backcourt space than other teams. It is thought that the performance of this high precision shooting play related to the high shooting efficiency of the NOR team.

We analyzed the relationship between the angle between left and right goalposts and the angle of shooting course in both scored goals and failed shots and found no significant differences among the teams in the slope of the angle between left and right goalposts against the angle of shooting course during scored goals and failed shots. In comparison between shooting results, the slopes of the angle between left and right goalposts against the angle of shooting course during failed shots were significantly smaller than those when goals were scored in CHN and KOR. In addition, the CVs during failed shots for those countries were larger in 6m and 9m shooting plays than during scored goals. This result means that the difference of precision shooting play between shooting results was larger at backcourt and 6m spaces even though there were no differences in that at wing space. In JPN, the intercept of slope during failed shots was significantly smaller than during scored goals even though the slope of the angle between left and right goalposts against the angle of the shooting course was similar in between scored goal and failed shots. This suggests that there was a large difference in the precision of shooting play in between shooting results irrespective of the shooting play space. In NOR, there were no differences in the intercept and slope of the angle between left and right goalposts against the angle of shooting course between scored goal and failed shots, suggesting good performance in shooting plays from NOR even when the shots failed. This precision shooting play during failed shots might relate to their high shooting efficiency.

Conclusion

In this study, we demonstrated that shooting play position and shooting course could be quantified using angular data and that the quantified data clarified the differences in the angle of shooting course among the teams during failed shots.

Using our method, these quantified data could easily be used to make a database of shooting play positions and shooting courses from a large number of matches. Furthermore, we would be able to identify tendencies of an individual or team to make particular shooting plays and observe development of individual or a team shooting plays in a time-series using the quantified data. There were a number of factors that were not considered in the data analyzed in the present study (game time, difference of score between teams, etc.). In the future we may be able to obtain more beneficial information by analyzing data from time-series events, direction of movement of a player just before a shooting play, game time and the difference of score between teams.

shiro@rs.noda.tus.ac.jp

PREDICTION OF BALL VELOCITY DURING STANDING THROW AND GAIN OF VELOCITY OBTAINED BY CROSS-OVER STEP

Guillaume LAFFAYE & Thierry DEBANNE

Department of Sport Sciences, Université Paris-Sud, Orsay, France

Summary

This study compared handball throwing velocity in two handball groups: an elite player group and a skilled player group. The gain obtained by the 3-step running is $2.24 \pm 0.75 \text{ m.s}^{-1}$ and is independent of the expertise. Elite players are taller (13cm, +6.85%) and heavier (17 kg, +18.91%), have better upper-limb strength than skilled ones (+18%). The high-velocity throwing technique is quite similar for a same population but slightly differs between both samples.

Keywords: detection, power, strength, leg stiffness, reactivity.

Introduction

Over-arm throwing is a complex motor skill which generally concludes an offensive phase of game by allowing a shot on the target. A review of the literature published on the subject shows that this topic has previously been investigated in four different ways.

Firstly, many authors have investigated the effect of skill on ball throwing velocity and noticed a significant difference in ball velocity between novices and skilled players during shots in standing position and with 3-step running. Secondly, anthropometric parameters have been assessed to explain a part of ball velocity. General anthropometric variables were better predictors than specific ones (e.g. hand perimeter, finger span, arm span). Thirdly, isotonic tests seem to be linked to ball velocity. Indeed, studies have shown that ball velocity is related to physical fitness characteristics, especially power and strength, assessing them either with general strength tests (e.g. bench press) or with more specific tests (medicine ball throw). Lastly, a few studies have combined predictive models with anthropometric and motor ability parameters in order to cross the influence of general anthropometric parameters and motor ability parameters on ball velocity in standing throw. These studies confirmed that physical fitness had greater influence than anthropometric variables. Thus, the goal of this study is to (1) investigate the gain obtained by the 3-step running; (2) investigate the effect of expertise on this gain and (3) predict the ball-throwing velocity in these three conditions (standing, with 3-step running, and difference between both) with both techniques by combining the best predictive variables.

Method

Sixteen independent variables were divided into three groups: 1) six anthropometric general parameters: body mass, lean mass, fat mass (FM), body height, body mass index (BMI) and Sheldon somatotyping index (SSI), 2) seven variables recorded during a hopping on place test (reactivity index, leg stiffness and vertical performance), a squat jump test (velocity, force, power output and vertical performance) to assess the lower-limbs strength and power; and 3) three physical fitness parameters: medicine-ball throwing with different loads (1, 2 and 3 kg) to assess the lower-limbs strength and power. The dependent variables were 1) ball velocity in standing position, 2) ball velocity with 3-step running, and 3) the difference between both velocities [m.s⁻¹].

Thirty-eight male handball players participated in this study. The sample group was divided into two sub-groups: the first one composed of twenty-five players playing in the professional Elite French championship (Elite), the second one composed of thirteen players playing in the Regional French championship (skilled players).

We measured participants to record their body height, we weighed them on bioelectric impedance scales (Weinberger model DJ-156), with 0.1% accuracy. Then, after a five-minute warm-up, participants performed a series of medicine-ball throws (1, 2 and 3 kg). After a 30-minute rest, they performed a series of five ball throws which were recorded using a radar gun. The three best performances (maximum velocity) were saved for further analysis to calculate mean velocity. The following week, we measured power, strength, vertical performance, reactivity index, contact time and leg stiffness for each athlete during three jumping tests: a hopping on place test, a squat jump test and a countermovement jump test.

Body height was measured using an anthropometer, with 0.1 cm accuracy. Body mass was measured using bio-electric impedance scales, with 0.1% accuracy. The BMI and the SSI were assessed by calculating the height/weight ratio. The SSI was calculated as followed: $\text{Height/Weight}^{1/3}$.

Upper-limb power measurement

To estimate muscle power, we chose an isotonic test, which has been showed in the published articles on the subject as strongly reliable to assess throwing velocity (e.g., Debanne & Laffaye, 2011). The upper-limb explosive power was assessed using a series of medicine-ball-throwing tests. In these tests, participants were instructed to throw a medicine ball of different mass (1kg, 2 kg,3 kg) as far as they could in a kneeling position, holding the ball over their heads. This position was chosen to evaluate upper-limb strength alone (Pineau et al., 1989). Each subject performed five trial throws with a one-minute rest between each.

Lower-limb power and strength measurements

To estimate lower-limb power, strength and reactivity, subjects performed two kinds of jumping tests: a hopping place jumping test with five repeated jumps (5H) and a squat jump test (SJ). Measurements were recorded using an isoinertial dynamometer (Myotest S.A., Switzerland) with a frequency of 500 Hz. For 5H, the players were asked to hop in place 5 times by maximizing the jump height and reducing the ground contact time. Altogether, each subject performed this procedure three times. The best result for this test was kept on the criteria of the best reactivity index (RI) for analysis. For SJ, subjects were instructed to (1) start from a standing position and to reach and (2) hold a semi-squat position (~ 90° knee flexion) until a beep was given by the device. Then, they had (3) to jump as high as possible without performing any countermovement before jumping.

Throwing velocity measurement

Ball velocity was evaluated by an over-arm throw in a standing position(i.e. stationary) and with a 3-step running. After a 10-minute warm-up, the subject was instructed to throw a standard handball (mass: 0.480 kg; circumference: 0.58 m) at maximal velocity at a 0.5 x 0.5 m target located in the middle of a standard handball goal (2 x 3 m) located seven meters away . Each subject performed five trials with a one-minute rest between trials. The three best performances were saved and averaged for further analysis. Ball velocity was recorded using a Doppler-radar gun (MATSPORT TRAINING, Radar ATS) with a frequency of 250 Hz and $\pm 0.027 \text{ m.s}^{-1}$ accuracy. The radar gun was located three meters behind the player, in the thrower-target axis at

a height corresponding to the player's height. In order to be as accurate as possible, only throws hitting the target were recorded for further analysis.

Statistical Analysis

The analyses were done using STATISTICA 7 software. Firstly, A 2 x 2 (Type of over-arm throwing X expertise) mixed-model analysis of variance (ANOVA) with repeated measures on the second variable was performed to determine if the use of 3-step running affected throwing velocity. The level variable (elite vs. skilled players) is a between-subject factor, and the type of over-arm throwing is a within-subject factor (standing position vs. 3-step running). Secondly, a Student T-test for independent groups was performed to determine if the values obtained on the independent variables were different for both groups. The level of significance chosen for the statistical analysis was $p=0.05$.

Lastly, Pearson correlation coefficients were used to determine the relationship between independent variables. Then, a multiple-regression analysis technique was applied to identify the most predictive models. The best model was kept for each population (elite, skilled players and all and then discussed.

Results

The mean value of ball velocity was 24.03 ± 2.05 m.s⁻¹ (21.91 ± 1.11 m.s⁻¹ for skilled players and 25.13 ± 1.49 m.s⁻¹ for elite players) in standing position and 26.26 ± 2.15 m.s⁻¹ with 3-step running (23.96 ± 1.40 m.s⁻¹ for skilled players and 27.46 ± 1.36 m.s⁻¹ for elite players). The gain obtained by the 3-step running is 2.24 ± 0.75 m.s⁻¹ [2.05 ± 0.72 m.s⁻¹ (8.56%) for skilled players and 2.33 ± 0.75 m.s⁻¹ (9.39%) for elite players]. The ANOVA revealed a significant effect of expertise [$F(1,35) = 55.7$; $p < 0.001$] and of type of over-arm throwing [$F(1,35) = 291$; $p < 0.0001$].

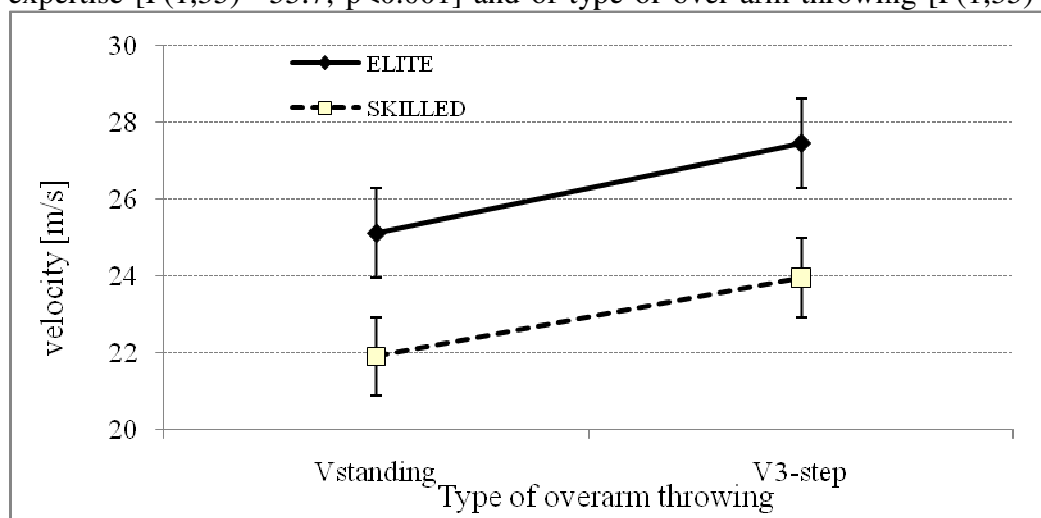

Figure 1. Effect of the type of over-arm throwing on ball velocity in elite and skilled handball players

Anthropometric parameters

Elite players are taller ($T=5.80$; $p < 0.001$, + 13cm or 6.85%) and heavier ($T=4.24$; $p < 0.001$; + 16.86 kg or 18.91%) than skilled players. Additional anthropometric variables (fat mass, lean mass and free fatty mass) showed the same significant difference (all $p < 0.05$). However, none of the somatotypic variables (BMI, SSI) showed a significant difference between both samples. Few anthropometric variables were correlated with the dependent variable. For elite players, only height was correlated with V3-step ($r=0.39$; $p < 0.05$) and SSI with ΔV ($r=0.43$; $p < 0.05$). For skilled players, only SSI was correlated with ΔV ($r=0.41$; $p < 0.05$).

Isotonic tests

Firstly, values of lower-limb strength and power seem very close for both groups. Secondly, values of upper-limb strength were higher in elite players for all the loads of medicine-ball (1 to 3 kg), with a difference of 1.59% from 17.35% to 18.94% (all $p < .001$). Lastly, the correlations observed between isotonic strength tests and the three dependent variables are quite similar for both samples. Indeed, all the values observed in both samples in the 3 MB tests were correlated with V_{standing} with r -values ranging between .56 and .76 (all $p < .05$). The best predictor for skilled players was MB_{2kg} ($r = .76$) whereas it was MB_{3kg} for elite players ($r = .63$). Moreover, none of the lower-limb tests were able to predict V_{standing} . The same prediction profile was noticed for $V_{\text{3-step}}$. MB tests were correlated with $V_{\text{3-step}}$ with r -values ranged between .45 and .68 (all $p < .05$). Once again, the best predictor for skilled players was MB_{2kg} ($r = .68$) whereas it was MB_{3kg} for elite players ($r = .54$). Only one variable recorded during the upper-limb tests was correlated with $V_{\text{3-step}}$ (SJvel with $r = .60$; $p < .05$). Concerning ΔV , few variables were able to predict the recorded values. Only SJvel was correlated with ΔV ($r = .70$; $p < .01$) in skilled players.

Multiple regression models

The best predictive model was kept for one of each dependent variable (V_{standing} , $V_{\text{3-step}}$ and ΔV) for elite players, skilled players and for all players. So, in total 9 predictive models were created (Table 1).

		Equation	r^2	p	ET (m/s)
	Elite	$0.861\text{MB-3kg} + .264\text{SII} + 5.84$.43	.002	1.19
V_{standing}	Skilled	$4.06\text{SJ-perf} + 0.79\text{MB-2kg} + 12.64$.63	.006	.76
	all	$6.56\text{HEIGHT} + 5.04\text{H5perf} + 0.84\text{MB3kg} + 2.7$.67	<.001	1.23
	Elite	$0.046\text{SSI} + .75\text{MB3kg} + 5.16\text{H5perf} - 1.08$.50	.002	1.04
$V_{\text{3-step}}$	Skilled	$0.24\text{SSI} + 8.35\text{SJ-perf} + 1\text{MB-2kg} + 0.48$.66	.01	.98
	all	$9.69\text{HEIGHT} + 8.94\text{H5-perf} + 0.47\text{MB2kg} - 0.2$.68	<.001	1.28
	Elite	$0.259\text{SSI} + 3.08\text{H5perf} - 9.83$.25	.04	.69
ΔV	Skilled	$-0.07\text{FM} + 1.48\text{SJv} - 1.17$.62	.007	.50
	all	$0.21\text{SSI} + 3.72\text{H5perf} - 8.25$.27	.004	.67

Table 1. Multiple regression model for ball velocity. ET= error terms

Discussion

The throwing velocities observed in the present study ($24.03 \pm 2.05 \text{ m.s}^{-1}$ in standing position and $26.26 \pm 2.15 \text{ m.s}^{-1}$ with 3-step running) are to our knowledge the highest ones recorded with adult male samples of elite handball players. In the present study the gain obtained by the 3-step running is $2.24 \pm 0.75 \text{ m.s}^{-1}$ [$2.05 \pm 0.72 \text{ m.s}^{-1}$ (8.56%) for skilled players and $2.33 \pm 0.75 \text{ m.s}^{-1}$ (9.39%) for elite players]. It is very close to the one found in previous studies [9% in Mikkelsen and Olesen (1976); 2.76 m.s^{-1} , 10.12% in Bayios & Boudolos, 1998 and 1.50 m.s^{-1} (5.9%) Gorostiaga et al., 2005]. However, we failed to find out an effect of expertise on this gain. So, the gain of velocity is independent of expertise.

Anthropometric parameters

Only height is significantly correlated with V3-step ($r=.39$, $p=.05$), with a value in conformity with the published articles on the subject (r between $.24$ and $.35$). That means that being tall allows to accelerate the ball on a longer distance, and so the velocity when the ball leaves the hand is greater. This suggests that the height is a crucial factor of expertise. Indeed, our study shows a difference of 13 cm between elite and skilled players whereas Gorotsiaga et al. (2005) found a smaller difference (+5cm). Actually, being taller brings kinematic advantages and also brings physical advantages during the offensive phase to jump high and to avoid the defenders' wall.

Isotonic tests

As expected, upper-limb tests are better predictors of the standing velocity than lower-limb tests. All MB tests have significant correlations with Vstand (r -values between $.54$ and $.76$). It is interesting to notice that the best correlation was obtained with MB2kg for skilled players and with MB3kg for elite players. This confirms that these tests are accurate to predict ball velocity and could be a good way to increase upper-limb strength (Pineau et al., 1989). Concerning ΔV , none of these tests are able to predict the gain of velocity.

None of the recorded variables during the lower-limb tests are correlated with Vstand, confirming that the velocity given to the ball in standing position is linked only to anthropometric factors and upper-limb strength (Debanne et Laffaye, 2011, Eliatz et Witz, 1996, Gorotsiaga et al., 2005). Concerning the ball velocity with 3-step running, low correlations were found for both samples. The comparison between elite and skilled players did not reveal differences between both groups, except for $SJ_{rel.force}$ (+14.10% for elite players), showing a better level of force during this jumping test.

In conclusion, elite players are taller (13cm, +6.85%), heavier (17 kg, +18.91%), have better upper-limb strength than skilled ones (+18% averaging on the three MB tests), but no difference has been recorded concerning the lower-limb strength and the somatotype.

Gain of velocity

Only H5 is significantly correlated with ΔV ($r=.38$, $p=0.02$) for both samples. H5 is the performance obtained during the hopping on place test. This kind of test has been previously assessed as a good indicator of plyometric qualities and leg stiffness (Farley et Morgenroth, 1999). Such a behavior during the 3-step running means that the player can run with short contact time, go forward very quickly and accelerate the ball with great efficiency. Such a link between the gain of velocity and the performance during the bouncing test implies that plyometric training could be a good way to increase this gain. SSI is the only anthropometric parameter to be significantly correlated with ΔV ($r=.41$., $p=0.01$). That means that a player with a high value of ectomorphism (i.e. thin morphology and long body segments) is more able to gain velocity by using the 3-step running.

Multiple regression analysis

For Vstand, models include at least a MB performance. The model for all subjects includes height and H5, i.e. one anthropometric factor and two isotonic tests. The MB3kg contributes to 90% and is the best predictor in the equation. That means firstly that upper-limb strength and power have greater importance than anthropometric factors. Secondly, Medicine ball seems to be an accurate way to predict ball velocity and to increase upper-limb power. Finally, the best predictive anthropometric factor depends on the sample. Indeed, in Elite players, SSI is the best predictor whereas height is the best predictor when gathering both samples, and body mass when the sample is more heterogeneous (Debanne et Laffaye, 2011).

For V₃-step, models include at least an isotonic test (MB or/and H5) and an anthropometric factor (SSI for both samples and height for all subjects). The best predictor is the medicine ball (from 75% for elite players to 84% for skilled players), but the contribution of the anthropometric factors increases slightly (from 7,4% for height in the model for all subjects to 19% for SSI in elite players).

For ΔV, models include the result of an isotonic test (SJv H5) and an anthropometric factor (SSI for both samples and elite; and Free Fatty mass for skilled players). The main result of the models for gain of velocity is that the greater contribution switches to anthropometric factors. Indeed, SSI contributes to 80% in the model for all subjects (respectively 86% for elite players), showing that being ectomorphic, with long upper-limb segments allows to accelerate the ball more easily. However, the accuracy of the model found on the gain of velocity is very low for elite and all subjects (25 to 27% of the variability).

Conclusion

To conclude, this study shows that the technique of throwing the ball with high velocity is quite similar for a same population but slightly differs between both samples. Moreover, the results of isotonic tests greatly contribute to this velocity whereas, anthropometric factors contribute only a little. Anthropometric factors are very important to discriminate population, but this difference reduces dramatically when zooming on a sample, especially the elite one. In other words, playing in elite level requires being tall, heavy (e.g., +13cm and + 17 kg in our study), with a wide arm span, being mesomorphic (Shroj et al., 2002; Sibila et Pori, 2009), but within this population, being taller or heavier does not guarantee throwing the ball quickly.

Finally, the gain in ball velocity obtained by the 3-step running is 2.24 ± 0.75 m.s⁻¹ [2.05 ± 0.72 m.s⁻¹ (8.56%) for skilled players and 2.33 ± 0.75 m.s⁻¹ (9.39%) for elite players]. The ball velocity in standing position and with 3-step running is significantly different between both samples, but without interaction effect, showing that the gain of velocity obtained by the 3-step running is independent of the expertise.

guillaume.laffaye@u-psud.fr

TRAINING PROGRAMS USED BY FRENCH PROFESSIONAL COACHES TO INCREASE BALL THROWING VELOCITY OF ELITE HANDBALL PLAYERS

Guillaume LAFFAYE & Thierry DEBANNE

Department of Sport Sciences, Université Paris-Sud, Orsay, France

Summary

The goal of this study is to understand through a survey how professional French handball players build their training program (TP). Results show that: 1) the time allotted to ball throwing velocity is a large part of the TP, 2) they based their TP on an accurate analysis of the ball throwing technique and 3) without academic background, coaches used beliefs rather than scientific knowledge to build their TP.

Keywords: *academic, workout, beliefs, knowledge.*

Introduction

Many authors (Gorostiaga et al., 2006; Debanne & Laffaye, 2011) have indicated that ball velocity is an important factor in throwing skill (performance) in team handball. The aim of this study is to understand how professional handball coaches build their training programs (TP) to increase ball throwing velocity in male elite handball players. Firstly, a short review of the literature on the subject will explain the biomechanical analysis of ball throwing and secondly studies on handball training programs will be discussed.

Joint movements during over-arm throwing

Some studies focus on the contribution of the angular velocities of the upper-limb joints (shoulder, elbow, wrist and hip) concerning over-arm throwing (e.g. Chagneau et al., 1992). This complex motor skill involves a quick shoulder internal rotation (e.g. Chagneau et al., 1992; Van den Tillaar & Ettema, 2004, 2007) combined with a rapid elbow extension. Both movements greatly contribute to ball throwing velocity (Van den Tillaar & Ettema ; 2004, 2007). However, the contribution of the wrist and fingers is still under debate. For some authors (e.g. Hore et al., 1996; Van den Tillaar & Ettema, 2004, 2007) the relationship between wrist flexion and ball velocity is uncertain. For others (Jöris, 1985 ; Wit, 1998) in former studies with indirect measure recording, a positive correlation has been found with these articulations and ball velocity. Van den Tillaar and Ettema (2007) showed a significant correlation for the timing of the maximal pelvic angle with ball velocity, indicating that the best throwers started to rotate their pelvis forward earlier during the throw. This may mean that the abdominal muscles are stretched earlier and more extensively during the movement and can build up more tension early on in the movement.

Effects of training programs on ball throwing velocity

Many authors have assessed the efficiency of TPs based on throwing velocity increase (Van den Tillaar, 2004 for review). These programs allows a gain in velocity of 2 to 6.9%. However, no consensus emerged from these studies. Van den Tillaar (2004) conclude by saying that no real answer has been given and only advices could be followed for example: (1) throwing velocity could be enhanced only if the TP consists of at least three trainings per week for five weeks ; (2) to be efficient, the TP must be based on individual parameters such as a player's experience. For

novices, the global TP generally increases throwing velocity. However, for high skilled players, a throwing velocity increase has been noticed after a program based on light ball throwing. In a recent study, Debanne et Laffaye (2011) have shown a high correlation coefficient ($r=.80$) between the performance of a medicine ball (2kg) throw in a kneeling position and throwing ball velocity in a standing position. This suggests that such a training could increase ball velocity. Moreover, the throw appears as a stretch-shortening cycle (SSC) movement that involves a high-intensity eccentric contraction immediately after a rapid and powerful concentric contraction. As shown in the model of muscular strength of Zatsiorsky (1995), plyometric training seems to be the most appropriate program to improve these movements (Malisoux et al, 2006). This short review confirms that there is no consensus about handball strength programs, which could generate confusion among handball coaches. To our knowledge, no study has investigated the content of strength TPs in high skilled players based on ball velocity increase.

Based on the articles written on the subject, we hypothesize that 1) the time allotted to the ball throwing velocity is a large part of the TP; 2) in order to increase this velocity, coaches focused on the shoulder internal rotation, elbow extension and abdominal oblique muscles and 3) coaches preferentially used concentric and plyometric muscular contractions.

Method

Participants and procedure

Considering the difficulty to reach the twenty-eight professional coaches, dispatched all over France, we decided to choose a classical survey rather than a semi-directive interview. The confidentiality of the answer was guaranteed to the participants. The survey was built in accordance with the review of literature exposed above. It is composed of three parts : 1- coach characteristics (age, number of years of experience, academic degree); 2- general strength program (kind of muscular contraction, physical qualities to be increased, exercises used for upper-limbs, tests used to check the validity of the TP); 3- handball specific strength program for upper limbs and trunk (part of strength TP allotted to the throw ; cognitive representation of the TP impact on ball velocity; TP specifically used to increase ball throwing velocity [wrist flexion, elbow, shoulder internal rotation; percentage of ball load used]). These parts are composed of closed questions. After each question, participants were allowed to write some additional comments. The closed questions use a Likert (1932) scale with 6 response categories to produce an ipsative (forced choice) measure where no indifferent option is available and ranging from strongly disagree=1 to strongly agree=6, or ranging from never=1 to always=6, or ranging from very low=1 to very important=6.

The surveys were sent by mail to the presidents and coaches of the twenty-eight professional clubs in November, 2010. In January 2011, eleven surveys were returned, and after two reminders, we finally received nineteen surveys (67,86%) from the professional coaches.

Statistical Analysis

Likert scales fall within the ordinal (Blaikie, 2003), because although the response degrees do have relative position, we cannot presume that participants perceive the difference between adjacent degrees to be equal. For each question, median (M) and inter-quartile range (IR) were noticed. We used non-parametric tests (Wilcoxon) for unpaired groups for all the questions and a student T-test for standard value for the question about the cognitive representation to determine if the answer mentioned by the coaches is in keeping with the value of the reviewed literature. The independent variable is the academic degree reached by the coaches.

Results

General Strength program

- type of muscular contractions used
A significant difference has been noticed concerning the kind of muscular contractions. Indeed, concentric (M=5 ; IR=1) and plyometric (M=4 ; IR=1) contractions are more used than eccentric (M=3 ; IR=2) ones (Z=3.3, p<.001 ; Z=3.24, p=.001 respectively), or isometric (M=3 ; IR=1) ones (Z=3.52, p<.001 ; Z=3.18, p=.001 respectively) or by electromyostimulation (M=1; IR=1) (Z=3.82, p<.001 ; Z=3.72, p<.001 respectively). The electromyostimulation is less used than the others. No difference has been found between eccentric and isometric contractions and between concentric and plyometric contractions. Moreover, a positive correlation has been noticed between the coaches' academic degree and the use of plyometric training. (r=.48 ; p=.037).
- goal to reach with the TP
Among the seven goals to reach (hypertrophy, flexibility, endurance, velocity, maximum force, power, prophylaxis), four are preferentially sought (p<.001) (velocity, maximum force, power, prophylaxis) rather than the three others.
- exercises used for upper-limbs
Some exercises are preferred to others for upper-limbs like bench-press and pullover. Indeed, 94.74% and 89.49% of coaches use « often », « very often » or « always » as regards the bench-press and the pullover for upper-limbs training, respectively. However, bench-press is more used than pullover (Z=2.54 ; p=.011)]. Results are summarized in table 1.

	Median	Mode	Range	Inter-quartile range
Bench-press	5	5	3	1
Incline Bench Press	2	2	5	2
Seated barbell military press	3	3	5	1
Pec-deck	3	2	4	2
Pullover	4	4	3	1
Pull-ups	3	3	4	2
Dips	3	2	3	2
Bar triceps extension	3	3	5	2
Curl	3	3	5	2

Table 1. Importance allotted to the main movements during handball upper-limbs TPs tests used to check the validity of the TP

Some devices and/or procedures are used to check the validity of the TP (e.g. one maximum repetition; use of an isoinertial dynamometer to check the kinematic parameters during squat or countermovement jump, bench press; optojump; photoelectric cellular...). The number is significantly correlated with the coaches' academic degree (r=.49 ; p=.03).

Handball specific strength program for upper limbs and trunk.

- Concerning the part of strength TP allotted to the throw
The time allotted to ball velocity increase is considered to be quite large or important by 61.11% of the coaches and low for 38.89% of the coaches.
- Cognitive representations of training impact on ball velocity

This question shows a lot of different answers, and 68.4% of coaches overestimate the impact of the TP on the increase of ball velocity ($t=4.42$; $p=.0004$)

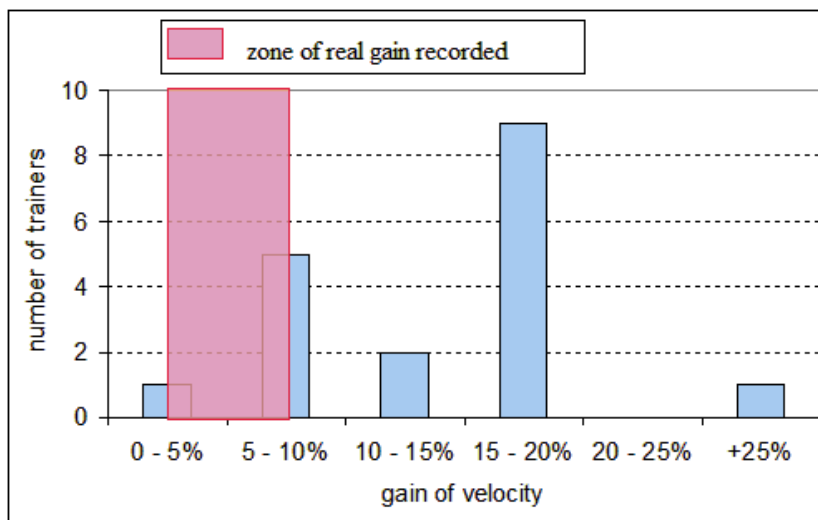

Figure 1. coaches' beliefs assumptions (blue) and knowledge (real gain recorded during experimental procedure) about gain of ball throwing velocity obtained after an appropriate TP.

- TP specifically used to increase ball throwing velocity

For upper-limbs, the increase of wrist flexion, shoulder extension and shoulder internal rotation is included in the goal of the TP « often », « very often » or « always » by 78,95%, 94,74% and 78,95% of the coaches respectively (see table 2). However, no significant difference has been noticed among these three joint movements ($Z=.34 - 1.12$; $p=.26 - .74$). The importance of the shoulder internal rotation is correlated with the coaches' academic degree ($r=.48$; $p=.04$).

	Median	Mode	Rang	Inter-quartile
Wrist flexion	4	4	3	1
Elbow extension	4	4	3	1
Shoulder internal rotation	4	4	3	1

Table 2. Upper-limb joint movements used by coaches

Concerning the trunk movement, all coaches use trunk rotation « often » « very often » or « always » and 94.74% of them use trunk flexion « often », « very often » or « always ». However, trunk rotation is more practised than trunk flexion ($Z=2.20$; $p=.028$).

- percentage of ball load used

In order to increase ball throwing velocity, coaches use overweight balls [0.800kg (178%) and 0.700kg (156%)] and underweight balls [T2 m=0.350kg (78%) or T1 m=0.310kg (69%)]. When coaches seek to increase ball velocity, 64.71% of them use overweight balls "often", "very often" or "always" , and 52.94% underweight balls, but the difference is not significant ($Z=1.48$, $p=.14$). However, a significant difference has been found between overweight balls (0.8kg) and underweight balls (T1=0.310kg) ($Z=2.00$; $p=.045$). The coaches' academic degree is significantly correlated with the use of underweight balls (T2=0.35kg) and overweight balls (T3=0.8kg) ($r=.60$; $p=.011$ and $r=.50$; $p=.039$ respectively).

	Median	Mode	Range	Inter-quartile range
Heavier balls (0.8kg + 0.7kg)	4	5	5	2
Lighter balls (0.35kg + 0.31kg)	4	1	5	4
Over-weight (0.8kg) balls	5	5	4	2
Over-weight (0.7kg) balls	4	4	5	2
under-weight (0.35kg) balls	4	5	5	4
under-weight(0.31kg) balls	2	1	5	4

Table 3. Ball loads used in the coaches' training programs

Discussion

The main goal of the present study was to understand how professional handball coaches build their TP to increase male elite handball players' ball velocity.

1) In accordance with our first hypothesis, the time allotted to ball throwing velocity increase is considered to be a large part of the TP. This confirms that the throw is a key moment of the offensive phase and that a gain in efficiency is a main concern for coaches. Indeed, several studies have shown that elite players have significantly higher ball velocity than high-skilled ones.

2) Our second hypothesis is validated. Indeed, as expected, coaches preferentially use movements of shoulder internal rotation, elbow flexion and trunk rotation in order to increase ball velocity. This is in accordance with the articles we have reviewed, especially with the kinematic analysis of the ball-throwing movement. There is only one exception with a belief about the importance of wrist flexion. Actually, coaches believe that the wrist flexion contributes to ball velocity but its real role is only to change the ball direction (Fradet et al., 2004) and to reduce the time of the arm acceleration in order to lower the time necessary to block for the defenders and to determine the good trajectory for the goalkeeper. This idea of TPs based on beliefs rather than knowledge will be discussed further.

3) As expected for the third hypothesis, coaches preferentially used concentric and plyometric muscular contractions. This is in accordance with the fact that the throw is a stretch-shortening cycle (SSC) movement that involves a high-intensity eccentric contraction immediately after a rapid and powerful concentric contraction. The electromyostimulation program is rarely used, maybe because trainers' experience in that area is insufficient.

4) Moreover, we found that the coaches' academic degree had an influence on different TP aspects, such as plyometric training, use of underweight and overweight balls, focus on shoulder internal rotation, use of tests to check the validity of the TP.

Indeed, two questions have clearly shown that some coaches use beliefs assumptions rather than scientific knowledge. The first one was about the gain that coaches could obtain after a cycle of strength increase. Actually, 68% of them greatly overestimate the effect of training. The second one was the part of each segment involved in ball velocity. 78,95% of them use a specific TP to strengthen the wrist flexion although this segment does not contribute to ball velocity. This kind of false beliefs rarely appears in coaches who have a high academic degree. Belief is a small

part of knowledge and is seen as a subjective idiosyncratic, personal characteristic which involves feelings (Alexander and Dochy, 95). Indeed, scientific knowledge is considered as objective as possible instead of beliefs which are a more subjective way of knowing, a personal truth. That is a main result of our study. This shows that it is necessary to have a high university degree in sport science to understand the complexity of the process of motor learning. A possible explanation of the effect brought on by the level of a coach's academic studies is that, a low academic level is compensated by beliefs based on the personal history of the athletes and the coach's own feelings.

Conclusion

This study shows firstly that the time allotted to ball throwing velocity is a large part of the TP. Secondly, coaches based their TP on an accurate analysis of the ball throwing technique. Lastly, without a proper academic degree, coaches used beliefs rather than scientific knowledge to build their TP.

Acknowledgements

We thank the Handball National League, the French Federation and the professional coaches union for their collaboration in this study.

guillaume.laffaye@u-psud.fr

INTERACTION IN 3D VIRTUAL WORLDS: AN INTEGRATED APPROACH OF EMERGING TECHNOLOGIES IN HANDBALL

* António LOPES¹, Pedro SEQUEIRA², Leonel MORGADO³, António MADEIRA², João ILDEFONSO⁴, Bruno PIRES³, Márcio CARDOSO³ & José DINIS⁴

¹Faculdade de Educação Física e Desporto da Universidade Lusófona de Humanidades e Tecnologias, Lisboa; ²Escola Superior de Desporto de Rio Maior do Instituto Politécnico de Santarém, Rio Maior; ³Universidade Trás-Os-Montes e Alto-Douro, Vila Real; ⁴Escola de Artes, Comunicação e Informação da Universidade Lusófona de Humanidades e Tecnologias, Lisboa, Portugal

Summary

Lifelong learning is a concept that is associated with changes in society as we know it. The new technologies of information and communication have contributed to the creation and development of various tools in the training, education and research in several areas. 3D virtual worlds are alternate realities in which people can interact with each other or elements present in it. In the field of education is recognized primarily by its potential ability to simulate complex situations, work collaboratively and also by "humanizing" the access and the transmission of knowledge asynchronously and synchronously.

The purpose of this communication is to present:

- the experiences acquired so far in handball, using the 3D virtual world of Second Life[®] as a training environment, and;
- an integrated view of various emerging technological resources to assist coach, coaching and competition situations.

Keywords: *Handball, Virtual Worlds, Artificial Intelligence, Interaction.*

3D virtual world as a training and coaching environment

3D multi-user virtual worlds are alternate realities where the people interact with each other and on elements present in it. In the field of training and education it recognized its potential, by a diversity of educational institutions. Virtual worlds are presented as alternative educational environments for the presentation of simulations, used to conduct experiments in adverse and expensive conditions, and sometimes impossible to be carried out in reality. 3D multi-user virtual worlds are technologies that present new possibilities for synchronous and asynchronous collaborative work, but also towards the improvement and humanization of access and transmission of knowledge through the Internet, and too having been playing an important role in developing strategies for innovative and effective teaching-learning (Morgado, in press; Warburton, 2009).

In sports context, an aspect of particular interest is the reproduction of dynamic aspects of the interaction of the game, allowing a better understanding of its characteristics. There is the ability to demonstrate the tactical issues in different perspectives and also on the modification of ongoing tactical procedures in real time. This technology has been tried out in the creation and simulation of 3D handball movements (Lopes, et al., 2009ab). The 3D virtual world Second Life[®] has been the choice since it has allowed an accessible way to study the process of teaching online, the software implementation

and the integration of motion captured handball movements in to bots in the virtual world.

In this regard have been developed: training activities to analyze the interaction between the trainees and the trainer; implemented software for the coach to interact with 3D virtual world simulator; and captured the movements and gestures of technical actions of players to produce handball animations to be simulated in the virtual world.

Training activities have been conducted in the virtual world Second Life ® in the form of synchronous classes (webinars), in which later took place content analysis of the chat logs of the participants, in order to verify the process of interaction between them and issues related to handball (Lopes, Sequeira & Rodrigues, 2009b; Lopes & Sequeira, 2010). Simultaneously, it has been developed software so that the future trainer/coach can use and control pre-programmed bots to perform 3D simulations of technical and tactical handball game situations (Lopes, et al., 2009). This will allow the trainer during to use the bots to simulate in real-time 3D tactical situations and adapt them to the educational and training needs, and that can be viewed from many perspectives (first person, blimp or bird eye view, coach/player by position view) and simultaneously interacting with them. For the simulation of handball gesture and movement to be closer to the real life ones, it has being captured the basic moves of the sport through MotionCapture ® (Lopes, et al., 2010).

An integrated view of emerging technological resources

The coach activity is essentially a social one, mainly constituted by the interaction between players and coaches (Jones, Armour & Potrac, 2002). During a game the coaches have to make several decisions, many of them critical and irreversible, with a high degree of uncertainty and on pressure (Salmela & Moraes, 2003; Sequeira, Rodrigues & Hanke, 2006). The use of specific knowledge of the sport appears to be consensus for successful coaches (Gilbert & Trudel, 2004). The proposal here presented plans to integrate and use a set of emerging technological innovations that simultaneously: record the actions of the game, simulate and analyze real-time in a sustainable way.

By studying the behavior of players and teams in the competition is possible to evaluate a team tactics and technically and transmit information back to the coaches and players, and to organize and develop databases for modeling (Hughes & Frank, 1997), thus define strategies to work.

The use and inclusion of technological means to collect information of the handball game has increased. The widespread use of gadgets such as smart phones and tablets enables us to foresee the need for adaptation and use of the potential of 3D virtual worlds in these devices. It is believed that the widespread use of such devices combined with 3D virtual worlds is a key factor in the process of communication and interaction of a team, either in a state of preparation, competition and/or training.

It is known the absence of a combined system, which allows a coach during a training session or game, ask playback of 3D sports movements, stop or resume as if it were a movie, involving the working group in the analysis of the game situation from different perspectives (Lopes et al, 2009).

Experience with VideObserver (www.videobserver.com) in systematic recording and simple statistic analysis of objective variables in real time, has demonstrated the feasibility of transmitting data in real time to an online platform. The VideObserver allows you to collect a wide range of technical and tactical data, which can be customized by the viewer, and to connect them in to match video. The major innovation and advantage is the simplicity of recording and the detailed data that can be obtained in real time.

The objective of wide data recording allows analyzing the complexity of the game of handball and even to simulate game situations. The simulation can be performed, for example by models of neural networks and their representation in a 3D virtual world online. This 3D simulation can be applied to training or competition situations, enhancing the development of solutions or the presentation of trends in game.

Once the needs and objectives of each of the sports agents are different the development of such technologies should consider the possibility of creating personal virtual environments.

antonio.m.lopes@ulusofona.pt

EXPERTISE EVALUATION OF TECHNICAL AND TACTICAL PROFICIENCY IN HANDBALL: DIFFERENCES BETWEEN PLAYING STATUS

Luís Miguel MASSUÇA

Faculty of Physical Education and Sport, Lusófona University, Lisbon, Portugal
ICPOL, Higher Institute of Police Sciences and Internal Security, Lisbon, Portugal

Summary

The aim of the present study was to analyse the “performance” of handball players (established on the basis of the subjective expertise assessment), in relation to playing status. In fact, it seems that the type of shots and the cognitive and game intelligence are discriminant variables of handball player proficiency.

Keywords: *Coaches, Evaluation, Handball-specific skills, Playing status*

Introduction

In handball (HB), players’ performance is an important subject to experts and coaches (Ökrös, 2006). The varieties of movement structures make HB one of the most complex sport games (Rogulj, Srhoj & Srhoj, 2004) and, to study the efficiency in HB game (see Gruić, Vuleta & Milanović, 2006; Ohnjec, Vuleta, Milanović & Gruić, 2008; Prudente, Garganta & Anguera, 2004), the assessment are usually based on: (1) evaluation sheets completed during matches (Taborky, 1991); or (2) video footage of the match (Vuleta, Milanović, Gruić & Ohnjec, 2005).

According to Trininić and Dizdar (2000), the set of criteria for the actual quality or performance evaluation in HB should focus on: the assessment of the situation-related or game efficiency of a single player in relationship to the phases of the game. So, it seems important to determine the significance (weighting factors) of each criterion in the performance evaluation.

In accordance, the present study was conducted to analyse the technical and tactical proficiency of adult male HB players from different Portuguese leagues (established on the basis of the subjective expertise assessment), and aim to identify the differences between playing status.

Methods

Study procedure and subjects

Seventeen expert HB coaches and 235 male HB players (age, 23.5±5.3 years) participated in this study. HB players were divided into five groups according to competition contexts, i.e., HB playing status groups: (1) Top elite (TE, n=35; age, 25.9±5.0 years); (2) Moderate elite (ME; n=72; age, 26.3±4.9 years); (3) Sub elite (SE; n=53; age, 24.4±4.3 years); (4) Moderate trained (MT; n=40; age, 24.2±4.9 years); (5) Under 21 (Next21, n=35; age, 18.8±0.9 years). Significant differences were found between groups in the chronological age ($F_{4,223}=34.735$, $p<0.001$), i.e., between under 21 all the other groups (all, $p<0.001$). All HB players were evaluated during the 2008-2009 Portuguese handball season (2009, February and March).

Handball-specific skills evaluation criteria

Despite the growing popularity and professionalism of HB in Portugal, the scientific literature, produced until this moment, does not include validated tools to assess the technical and tactical proficiency of HB athletes. So, was adopted the grid suggested by Blanco (2004)), and a set of ten criteria for evaluating handball-specific skills was used, namely:

- (1) Types of marking (TM);
- (2) Ability to retrieve balls (RB);
- (3) Ability to escape the opponent (D);
- (4) Pass and reception (PR);
- (5) Type of shots (R);
- (6) One vs one (1 vs 1);
- (7) Ability to create and fill up spaces (COE);
- (8) Offensive and defensive battle (MT);
- (9) Defensive collaboration (CD);
- (10) Ability to vary their actions (VA).

All HB players were evaluated by coaches (on a Likert type scale ranging from “very poor” - 1 to “excellent” - 5). Complementarily, four scores were calculated: (1) technical skill (Sum (item 1 to 6)); (2) tactical skill (Sum (item 7 to 10)); (3) offensive skill (Sum (item 3 to 8 and 10)); and (4) defensive skill (Sum (items 1, 2, 9)).

Statistical analyses

All calculations were performed using the SPSS statistical package (SPSS Science Inc., Chicago, Illinois, USA). Descriptive and comparative data of significant dependent variables were presented, and group data were expressed as means and standard deviations ($M \pm SD$). Two different sets of analyse were undertaken: (1) univariate analysis of variance (ANOVA One-Way) in which playing status was the between-participant variables (follow-up a multiple comparisons test, Tukey HSD Post Hoc); and (2) discriminant function analysis (Stepwise method) was used to determine which combination of measures best discriminated the playing status groups. For all analyses, 5% was adopted as the significance level.

Results

Significant difference were observed in: (1) type of shots ($F_{4,197}=4.266$, $p<0.001$); (2) ability to escape the opponent ($F_{4,198}=3.825$); (3) ability to create and fill up spaces ($F_{4,196}=4.065$); (4) offensive and defensive battle ($F_{4,205}=4.874$); (5) ability to vary their actions ($F_{4,206}=4.492$, all $p<0.01$); (6) pass and reception ($F_{4,212}=3.256$); (7) ability to retrieve balls ($F_{4,204}=3.013$); and (8) one vs one ($F_{4,197}=3.267$, all $p<0.05$). No significant differences were observed between playing status groups in: (1) types of marking ($F_{4,202}=1.073$); and (2) defensive collaboration ($F_{4,209}=1.939$).

Tukey HSD Post-Hoc tests indicated that top elite were significantly better than: (1) moderate elite in the ability to escape the opponent ($p<0.01$), pass and reception ($p<0.05$), type of shots ($p<0.001$), one vs one ($p<0.05$) and in offensive and defensive battle ($p<0.01$); (2) moderate trained in the ability to escape the opponent ($p<0.05$), ability to create and fill up spaces ($p<0.01$), offensive and defensive battle ($p<0.01$) and in the ability to vary their actions ($p<0.01$). Also Next21 scored better than: (1) moderate trained in the ability to vary their actions ($p<0.05$), and (2) moderate elite in type of shots ($p<0.05$). All these findings are presented in Table-1.

Complementarily, (1) significant differences were found in technical ($F_{4,212}=3.771$, $p<0.01$) and tactical ($F_{4,209}=4.827$, $p<0.01$) scores, and (2) no significant differences were observed in offensive ($F_{4,230}=1.467$, $p=ns$) and defensive ($F_{4,230}=1.020$, $p=ns$) scores. Follow-up, Post-Hoc tests indicated significant differences between the status group in technical and tactical skills. These findings are presented in Figure-1.

Table 2. Handball-specific skills evaluation and playing status.

Variables	Descriptive statistics												ANOVA		Tukey HSD Post-Hoc tests												
	Next21		MT		SE		ME		TE		F	Sig.	Next21		Next21		Next21		Next21		Next21		Next21				
	N	M±SD	N	M±SD	N	M±SD	N	M±SD	N	M±SD			MT	SE	ME	TE	MT	SE	ME	TE	MT	SE	ME	TE	MT	SE	ME
(2) Ability to retrieve balls	57	3.37±0.70	32	3.03±0.65	37	2.95±0.91	47	2.91±1.02	36	3.39±1.08	3.013	0.019															
(3) Ability to escape to opponent	54	3.44±0.77	32	3.09±0.69	34	3.38±0.89	47	3.00±1.14	36	3.72±1.06	3.825	0.005															0.005
(4) Pass and reception	59	3.54±0.68	34	3.38±0.74	38	3.71±0.93	50	3.34±0.94	36	3.94±1.04	3.256	0.013															0.013
(5) Type of shots	52	3.42±0.85	33	3.21±0.78	34	3.26±0.79	47	2.89±0.98	36	3.78±0.99	4.266	0.000			0.028												0.000
(6) One vs one	52	3.29±0.87	33	3.12±0.82	34	2.91±1.08	47	2.85±1.12	36	3.56±1.03	3.267	0.012															0.013
(7) Ability to create and fill up spaces	52	3.40±0.77	32	2.91±0.82	34	3.21±0.91	47	3.17±0.76	36	3.67±0.96	4.065	0.003															0.002
(8) Offensive and defensive battle	55	3.38±0.73	32	2.88±0.91	37	3.19±0.94	50	3.06±0.82	36	3.72±1.11	4.874	0.001															0.001
(10) Ability to vary their actions	57	3.35±0.72	32	2.75±0.76	37	3.19±0.94	49	3.04±0.84	36	3.53±1.00	4.492	0.002	0.013														0.002

Playing status: Next21, Under 21; MT, moderate trained; SE, sub elite; ME, moderate elite; TE, top elite.

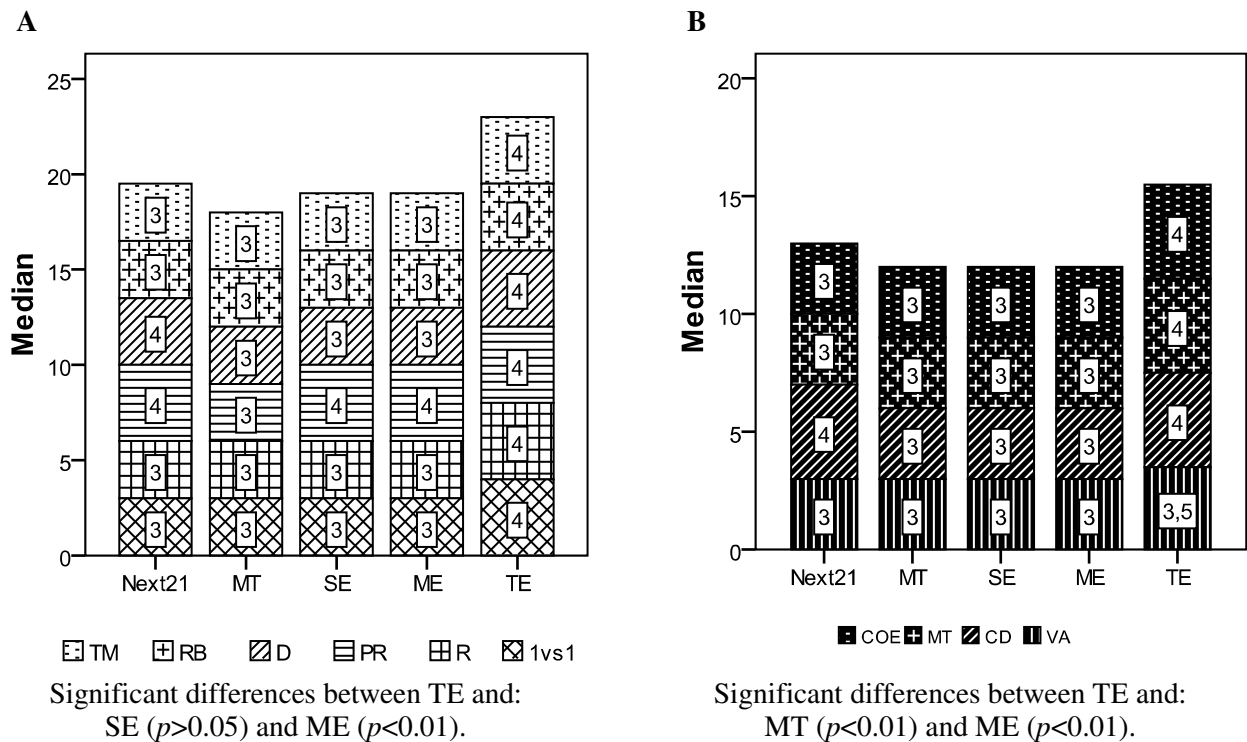

Legend:

Playing status: Next21, Under 21; MT, moderate trained; SE, sub elite; ME, moderate elite; TE, top elite.
 Variables: 1 vs. 1, one vs one; CD, defensive collaboration; COE, ability to create and fill up spaces; D, ability to escape the opponent; MT, offensive and defensive battle; PR, pass and reception; R, type of shots; RB, ability to retrieve balls; TM, types of marking; VA, ability to vary their actions.

Figure 1. Scores on technical (A) and tactical (B) skills by playing status.

Stepwise discriminant analysis

Results showed that a combination of two variables successfully discriminated the playing status groups, i.e., type of shot and tactical skills. First function (Wilks' Lambda=0.826; $\chi^2(8)=37.458$; $p<0.001$) discriminated the five groups and explain 54.9% of variance, and the second (Wilks' Lambda=0.917; $\chi^2(3)=16.970$; $p<0.01$) explain 45.1% of variance. Classification results showed that 29.9% of original group cases and of cross-validated grouped cases are correctly classified. These findings are presented in Table-3 and Figure-2.

Table 3. Standardized canonical discriminant function coefficients, eigenvalues and variance, by playing position groups, do discriminate playing status groups.

Variables	Function 1	Function 2
Type of shots	1.137	-0.843
Tactical Skills	-0.208	1.400
Eigenvalue	0.110 ^d	0.090 ^d
% of Variance	54.9	45.1

^d First 2 canonical discriminant functions were used in analysis.

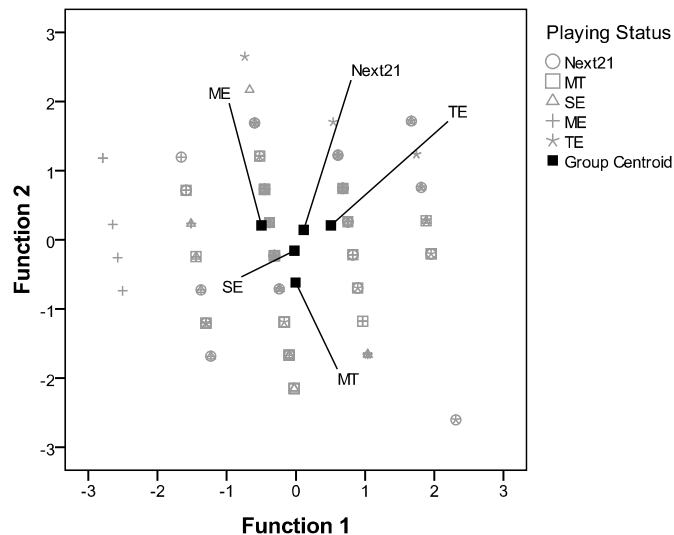

Playing status: Next21, Under 21; MT, moderate trained; SE, sub elite; ME, moderate elite; TE, top elite. Variables: 1 vs. 1, one vs one; CD, defensive collaboration; COE, ability to create and fill up spaces; D, ability to escape the opponent; MT, offensive and defensive battle; PR, pass and reception; R, type of shots; RB, ability to retrieve balls; TM, types of marking; VA, ability to vary their actions.

Figure 2. Canonical Discriminant Funcions (N = 235).

Discussion

The technical and tactical proficiency of adult male HB players from different Portuguese leagues were indirectly measure by handball experts and coaches, on the basis of a suggested set of criteria proposed by Blanco (2004). The results showed that there is a strong relation between technical and tactical proficiency with HB playing status. Furthermore, were found that two dimensions successfully discriminated between the five playing status groups, namely: (1) type of shots, and (2) cognitive and game intelligence. In other words, it seems that the tactical activity is a crucial feature of elite HB game. Defined by Rogulj, Srhoj and Srhol (2004) as “a planned and premeditated management of all system dimensions to reach the goal (i.e., to win), within the frame of current conditions and opposed activity of the contestant”, the tactical activity have as essence to usefully employ the potentials available. This is the main focus! However, remember that in this small study, the tactical skills score results from the sum of four items (only!). We believe therefore that must be studied and built a more complete instrument for this purpose. In my opinion, the assessment of an HB player proficiency is one of the most fundamental and responsible aspects of coaching. Moreover, its information can be used for the decision making when selecting players.

Conclusion

To the author knowledge, this study provides the most comprehensive expertise evaluation of technical and tactical proficiency in Portuguese handball players and, this is one of the largest studies in regard to sample size (n=235). In conclusion, the type of shots and the cognitive and game intelligence are discriminant variables of handball player proficiency. Moreover, expertise evaluation of HB player is relevant to the teaching-learning process, because provides him (HB player) the opportunity to be faced with features of his game and, will inspire players' and coaches reflection.

GOALKEEPERS' HRV INCREASE BEFORE HANDBALL COMPETITIONS

Andris MOLOTANOVŠ, Renārs LICIS, Jānis ŽIDENS

Latvian Academy of Sport Education

Summary

The aim of this research is to state the condition of goalkeepers' autonomic nervous system (ANS) before a handball game and to investigate whether some indicators that reveal ANS activities are linked with goalkeepers' activity effectiveness during competitions. The parameters of the heart rate variability (HRV) were registered, the Time-domain method and Frequency-domain method were used.

Keywords: *competition, goalkeeper, handball, heart rate variability*

Introduction

In order to deflect the ball in handball a goalkeeper should follow it, at the moment of the shot he should focus his attention on the forward's shooting hand, evaluate the possible variants of the shot, taking into account the forward's place and position in regard to defenders, make a decision where to execute the ball deflecting movement, quickly perform the movement and deflect the ball which is shot into the goal with the speed 30 m/s [1].

Too big excitement before the competitions, stress or fatigue can impede a goalkeeper to make the right tactical decisions during competitions.

Clinical research shows that psychological, mental or emotional fluctuations are closely connected with the autonomic nervous system (ANS) [2]. If there are changes in physiological variables, it can cause chronic influence on the psychological factor [3]. If during the load these variables are accurately controlled, it will be an effective method to improve study quality [4]. Among many physiological parameters concerning ANS, the heart rate (HR) is the simplest and the most easily accessible, while other parameters like the skin resistance, breathing and blood pressure are not so easily applicable in everyday practice.

Studies show that alterations in autonomic balance under physical load can be examined non-invasively by evaluating HRV [5-7]. Other studies about modifications of the cardiovascular system what is regulated by the ANS and fatigue caused by exercise or training for endurance athletes used HRV analysis [8-11]. The aim of our research is to quantify the changes in the ANS function associated with psychological and emotional fluctuations of the handball goalkeepers before the competitions and to try to state if some spectral indices that reflect the activity of the ANS are related to sports result in competitions.

Methods and Materials

A. Subjects

Three handball goalkeepers (male) participated in the study, all three of the Latvian Higher League LSPA team goalkeepers. One goalkeeper (elite athlete) is the Latvian team goalkeeper, two goalies (amateur athletes) played in the youth and junior teams. All goalkeepers are physically healthy, free of heart disease and diabetes. Their age ranges from 23-29 years of age, and experience lasting from 11 to 20 years.

B. Data Acquisition

Two-channel heart beat signal capture device (Omega - M produced in the laboratory "Dynamics", Russia) was used to collect ECG signals from the subjects. Sampling frequency is 1000 Hz and the converter resolution is 12 bits. ECG data collection took place with subjects sitting at rest 60-90 minutes before the event. Omega - 300 M recorded cardio cycles.

During the competition we registered deflected balls by the handball goalkeeper and successful balls - shots on goal from long range 8 - 9m, close range 6 - 7m and the percentage of the deflected balls.

During the study, goalkeepers participated in different levels of competition in the Baltic League, Tallinn and the Latvian Cup championship. In the Baltic League and Cup Tallinn (high level - a superior team, or the equivalent rating) the best handball teams of the Lithuania, Estonia, Latvia and Finland participate. Latvian Championship (medium level) 2 from 9 teams were equivalent and 7 were of lower level.

C. Methods

HRV analysis is based on the RR - interval measurements. Electrocardiography (ECG) signals were filtered from the artifacts. Then Time-Domain Methods and frequency-domain method were used.

Time-domain Methods thesis are based on the beat-to-beat or NN interval, which are analysed to give variables such as: SDNN, the standard Deviation of NN interval. Often calculated over a 24-hour period, SDANN, the standard Deviation of the average NN interval calculated over short period usually 5 minutes. SDANN is therefore a measure of change in heart rate due to cycles longer than 5 minutes, RMSSD, the square root of the mean squared difference of successive NNS. Frequency-domain method. Then a method of fast Fourier transform was used to calculate the power spectra of different frequency bands for all the data. It was resolved in three major spectral power: very low frequency (VLF: 0,003-0.04 Hz), low frequency (LF: 0,04-0.15 Hz) and high frequency (HF: 0.15 0.40Hz) indicators. HF power is associated with the parasympathetic nervous system, the sinus node, linked to respiratory activity, whereas LF power reflects mixed sympathetic and parasympathetic activity, or modulation of sympathetic activity only. The correlation between the sympathetic and parasympathetic nervous system was evaluated LF / HF. VLF, LF and HF components of power measurement is usually carried out in absolute values of power (milliseconds squared). LF and HF can be measured in normalized units (usually called LFnorm and HFnorm, respectively), reflecting the relative value of each power component in proportion to the total power minus the VLF component. LFnorm HFnorm and stresses in a controlled and balanced behaviour of both ANC. Output parameters primarily include the average heart rate (HRAve), VLF, LF, HF, LF / HF, RRNN, SDNN, SDANN, RMSSD.

In the study, we paid attention to the relationship closeness on average close correlation of 0.4 – 0.7 and a close correlation > 0.7.

Results

By calculation, statistical analysis and correlation analysis, we have found that the elite athlete in the Baltic league competition (10 games) For the Latvian National Team goalkeeper the average competition activity index is 29.3% from 6m, from 9m is 46.9 and 34.8% in total. There is a medium close interrelationship (correlation) between the competition indicators and heart rate variability parameters: AVE% and

HRAve ($r = -0.477$); AVE% and RRNN ($r = 0.439$); AVE% and VLF ($r = 0.575$), 9m%, and VLF ($r = 0.532$). In the Latvian Championships (16 games), the average competition activity index is 44.8% from 6m, from 9m is 55.9% and the total (AVE) is 52.1%. There is a medium close interrelationship (correlation) between the competition indicators and heart rate variability parameters: 6m% and HRAve ($r = 0.500$); 6m% and RMSS ($r = 0.439$); 6m%, and VLF ($r = -0.444$); AVE% and HF% ($r = -0.428$); 6m% and LF % ($r = 0.606$); AVE% and LF% ($r = 0.464$); AVE% and HFnu ($r = -0.499$); AVE% and LFnu ($r = 0.408$); 6m% and LF / HF ($r = 0.456$). In the Tallinn Cup competitions (5 games) the average competition activity index is 29.5% from 6m, from 9m 47.4% and the total (AVE) is 38.9%. There is close interrelationship (correlation) between the competition indicators and heart rate variability parameters: 9m% and HRAve ($r = -0.722$); 9m% and RRNN ($r = 0.736$); 9m% and RMSSD ($r = 0.839$); AVE% and RMSSD ($r = 0.734$); 9m% and HF ($r = 0.869$); 6m% and LF ($r = 0.808$); AVE% and LF (**$r = 0.994$**).

For medium-level goalkeepers (amateurs) in high-level competitions (Baltic League) the correlation between the competition indicators and HRV parameters were not observed, as the goalkeeper had participated in four games.

For the medium-level goalkeeper Nr 2 (amateur) in middle-level competition results (in Latvian Championship) the average competition activity index is 29.3% from 6m, from 9m is 46.9 and 34.8% overall. There is medium close interrelationship (correlation) between the competition indicators and heart rate variability parameters: HRV% and HRAve ($r = -0.436$); AVE% and RRNN ($r = 0.456$); AVE% and SDNN ($r = 0.602$); AVE% and CV ($r = 0.536$); AVE% and HF ($r = 0.444$); AVE% and VLF ($r = 0.598$).

For the medium-level goalkeeper Nr 3 (amateur) in middle-level competition results (in Latvian Championship) the average competition activity index is 41.2% from 6m, from 9m is 58.3 and 49.2% overall. Medium close interrelationship (correlation) between the competition indicators and heart rate variability is not observed.

Conclusions

Our initial findings show that for a higher level (Latvian National Team) handball goalkeeper the correlation between HRV and the competition indicators is **medium close** in the Baltic league competitions (very high level) and in the Latvian Championship competitions (intermediate level), while in Tallin Cup **close** correlation is observed.

For medium-level goalkeepers (amateurs) medium close **correlation 0.4 to 0.7** between HRV indices and middle-level competition result was observed.

HRV results obtained shortly before the competitions allow us to predict the performance of goalkeepers in handball competitions.

HRV analysis should be used following the principle of individualization, HRV parameters which correlates with the competition result or control exercises (test indices) should be stated individually for each athlete.

HRV analysis may be a new approach in sports science in handball goalkeepers' pre-competition control process before the competition. HRV may be of practical value in assessing the quality of training, psychological stress before competitions.

andris.molotanovs@gmail.com

BASIC ENDURANCE PERFORMANCE IS HIGHLY CORRELATED TO MEAN HEART RATE IN FEMALE TOP LEVEL HANDBALL PLAYERS

Petra PLATEN¹ & Carmen MANCHADO²

¹Ruhr-University Bochum, Bochum, Germany; ²University of Alicante, Alicante, Spain

Summary

Players of the German female national team wore heart-rate- (HR-) monitoring belts during 7 matches of the EC in 2004. The players had a mean action time of 41.4 ± 15.2 min, mean HR was 161.7 ± 11.9 bpm, corresponding to 85.8 ± 3.2 % of HR_{max} . Velocity corresponding to 4 mmol/l lactate (v_4) was negatively correlated with mean % HR_{max} . This is a clear indicator for the necessity of the development of a high aerobic capacity in international female top level handball.

Keywords: *Women's handball, endurance, heart rate, aerobic capacity, action time*

Introduction

International female handball has increased dramatically in its dynamics and intensity in the last years. The exact demands of modern female top level handball, however, have not been investigated systematically so far. This is especially true for the time period of the past few years, after changes in rules were developed that impact game intensity. Statistics from the 1999 and 2003 World Championships for women show that the total number of attacks increased by nearly 10 % after this rule change (Spencer et al. 2005). In general, for sports science and professional disciplines, it is interesting and useful to investigate the demands imposed on players in sports games.

It is astonishing that the handball-specific physiological demands have not been investigated systematically, neither in the past, nor during the years following the rule changes described above. This may be due to a lack of methods that can be used during competition in order to analyze physiological reactions. Individual heart rate, however, is a relatively easy-to-use parameter, especially since the development of the "Polar® Team System," which allows the storage of heart rate data in a transmitter that can be worn during competition without risk of injury. Continuous measurement of heart rates allows analysis of individual physiological demands during intermittent exercise, including team sports (Miyamura et al. 1996), because variations in heart rate during exercise correlate with a small time delay with alterations in exercise intensities (Achten et al. 2003). The aim of this investigation was to analyse physiological demands of elite women's handball matches using heart rate monitoring as indicator of individual physiological stress response and to analyse the effect of higher aerobic performance on these demands during matches.

Methods

7 matches of the German female national team during the European Championship in 2004 were recorded. 14 of 16 players of the German team (age: 26.6 ± 3.8 yrs, height: 176.0 ± 7.4 cm, weight: 70.4 ± 6.8 kg) agreed to wear heart-rate-monitoring belts (Polar, team system) during the matches. For further analysis, mean HR of the real playing phases of each player were calculated in 12 players. Individual maximal HR had been determined prior to the tournament during a shuttle-run test (Grant et al. 1995). Velocity corresponding to 4 mmol/l lactate concentration (v_4) had been determined in a preceding incremental field test (Mader et al. 1976, Billat et al. 2003). Total playing time, time of attack and defence periods, real playing time (e.g. the time when the ball was on the field and time was running), and time of highly intensive attacks of the matches of the German team were analysed by video capturing.

Results

Mean maximum HR was 186.7 ± 8.3 bpm and varied remarkably between 173 and 199 bpm. Mean v_4 was 3.34 ± 0.31 m/s and varied between 2.7 and 3.7 m/s. Mean total duration of the matches was $72:14 \pm 2:92$ min:s (69:15 to 75:55 min:s). Real playing time, however, only was $43:06 \pm 2:53$ min:s (38:08 to 45:55 min:s). Number of attacks was 57.5 ± 3.8 (53 to 63) per match and 28.2 ± 2.8 per half time. Mean time of one attack from all matches was 23.0 ± 1.9 sec. High intensive phases of attack had a mean duration of 5.8 ± 0.4 sec.

Playing time of the players varied widely between 2 and 74 min (41.7 ± 5.1 min). Mean HR also varied remarkably between 140 and 189 bpm (161.1 ± 3.3 bpm) (table 1). Maximum HR reached 171 to 200 bpm during the matches. Mean individual percent HR_{max} was 85.8 ± 3.2 % and varied between 74.7 and 91.7 % (table 2). 8 of the field players had a mean playing time higher than 30 min. In this subgroup mean percent HR_{max} correlated highly and significantly with aerobic performance (v_4 , $r=0.96$, $p<0.01$, figure 1).

Table 1: Mean (mean) playing time (in minutes) and heart rate (HR, in bpm) of the players, standard deviation (Sd), minimum (Min) and maximum (Max) values) during all 6 matches; DEN: Denmark, ROM: Romania, HUN: Hungary, AUT: Austria, FRA: France, UKR: Ukraine

			DEN	ROM	HUN	AUT	FRA	UKR	Mean	Sd
Mean	Playing time	min	41.2	41.7	39.9	37.1	38.9	51.5	41.7	5.1
Sd		min	27.8	24.9	21.1	17.2	21.7	26.7		
Min		min	8	10	9	11	2	12		
Max		min	70	74	73	68	71	74		
Mean	HR	bpm	166.5	159.8	157.9	159.4	159.3	163.9	161.1	3.3
Sd		bpm	32.9	40.7	31.1	34.8	36.8	36.5		
Min		bpm	151	144	140	146	142	150		
Max		bpm	189	167	173	180	184	186		

Table 2: Mean (mean) and standard deviation (Sd) of percent use of maximum heart rate (%) of the single players and mean and standard deviation of the whole group during all 6 matches; DEN: Denmark, ROM: Romania, HUN: Hungary, AUT: Austria, FRA: France, UKR: Ukraine

Player		DEN	ROM	HUN	AUT	FRA	UKR	Mean	Sd
1	%	76.5	74.5	75.0		76.5	78.1	75.6	1.4
2	%	88.4	92.5	93.0	93.0			91.7	2.2
3	%	87.9	84.4	82.7	86.7	80.9	83.2	84.5	2.6
4	%		81.8	75.9		85.6	87.7	81.1	5.2
5	%	82.1	85.3	84.8	82.1	80.4	87.5	82.9	2.6
6	%					84.5		84.5	
7	%	89.3	88.8	85.7	80.1	88.3	88.8	86.4	3.5
8	%	100.0	86.9	87.4	89.1	90.3	84.6	90.7	5.4
9	%	90.2	83.7	81.0	89.1	89.7	88.0	86.7	3.7
10	%	91.0	87.0	91.5	94.4		93.2	91.0	2.8
11	%	93.5	83.7	87.0	89.1	90.2	90.8	88.7	3.4
12	%					74.7		74.7	
13	%	90.7	87.4	89.6	85.7	87.9	87.9	88.2	1.7
14	%	97.9	93.3	95.3	96.4	87.6		94.1	4.0
Mean	%	89.8	85.8	85.7	88.6	84.7	87.0	85.8	3.2
sd	%	6.5	4.9	6.3	5.2	5.4	4.2	5.7	

Figure 1: Correlation between mean percent of maximum heart rate ($\% Hf_{max}$) and v_4 in the subgroup of field players who played at least 30 min per match ($\% HR_{max}$, $r=0.96$, $p<0.01$; $n=8$).

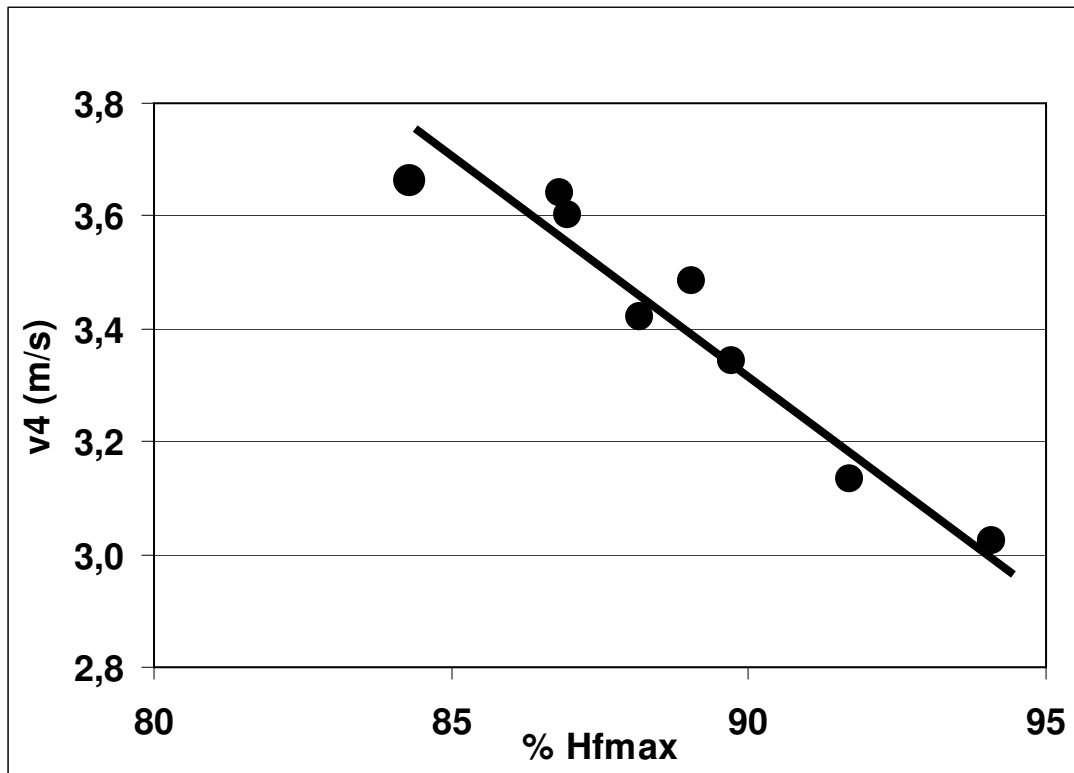

Discussion

Total demands during a handball match are determined mainly by the real active playing time. However, under the aspect of total energy expenditure, also the low intensive phases of a match which summed up to about 29 min in this investigation, and the time of warming up (about 30 min) are important. Active playing time (43 min in this investigation) was nearly the same as had been reported in men's handball more than 10 years ago (Czerwinnski 1993). Former values in women's handball are not available. During a tournament with many successive matches, total active playing time during the whole tournament is also important. In an investigation of the Norwegian national team, mean total active playing time in 3 consecutive matches in a friendship tournament was 85 ± 33 min (44 – 134 min), according to 28 min (15-45 min) per match (Ronglan et al. 2006). Mean active playing time in our investigation was 42 min per match in the German team during the European Championship, indicating, that the trainer focussed on a relatively small number of established and experienced players in this important tournament. Such a tactical measure results, however, in quite a high total demand of these players.

The match of the German team was relatively slow (only $n=58$ attacks) as compared to the final and bronze-medal matches during the World Championship (WC) in 2005 with $n=78$ and $n=69$ attacks, respectively (statistics of the International Handball Association (IHF)). During the finals of the men's WC in 2007 number of attacks was 69 (IHF). This indicates the necessity of relatively faster matches with more attacks for reaching a good placement during an international tournament.

Most of the goal-relevant actions in handball are the result of short, high-intensive moving patterns. Therefore, these phases are of major importance for the match. We counted nearly $n=80$ of these phases with a mean duration of 6.0 ± 0.3 s and a high variability in duration of 2 - 15 s per high-intensive phase. One older study in men found a mean duration of 4 - 5 s of high-intensive phases during attacks (Espar 1988). Therefore, high performance in handball as in

other game sports includes the capacity to compensate for repetitive, short, and high-intensive movements without fatigue for the duration of a whole match. This requires a fast creatine-phosphate resynthesis (Glaister 2005). Moreover, the somewhat longer lasting intensive phases require a fast and efficient ATP resynthesis from the glycolic energy pathway, which is accompanied by a physiologically relevant lactate production. In earlier years, studies reported lactate concentrations in handball players of 8 mmol/l (Haralambie et al. 1981). The higher the aerobic capacity of a player, the faster and stronger lactate elimination occurs (Billat et al. 2003). Acidosis of the organism including negative effects on performance (e.g. reduced muscular performance, reduced concentration, a possibly higher injury risk etc.) is probably reduced even during high intensive phases in those players who have a better development of aerobic performance (Platen 1989).

Heart rate during a match might be used with some restrictions as indicator of the intensity of intermittent exercises like sport games. Oxygen consumption and real individual energy demands might be estimated using mean heart rates, when individual HR behaviour and oxygen uptake are known (Achten et al. 2003, Lothian et al. 1995, Miyamura et al. 1996). This is approximately also true for intermittent exercises (Lothian et al. 1995). Only few data on heart rates during handball matches are available in the literature. In male players mean heart rate during a whole match was reported to be between 75 and 80 % HR_{max} (Chirosa et al. 1999). In female field hockey, players HRs were between 82 and 87 % HR_{max} (Sunderland et al. 2006). An older investigation in women's soccer showed HR values between 89 and 91% HR_{max} (Brewer et al. 1994). Altogether, mean percent HR_{max} values did not differ remarkably between the different sport games, although muscular energy supply clearly differs between the sport-specific moving demands like intermittent, shorter or longer sprinting (Glaister 2005, Spencer et al. 2005). To get more insight into the relevant metabolic reactions, further studies combining the analysis of movement patterns and individual physiological reactions including heart rates in the different sport games are necessary.

In our investigation, intra-individual variation in % HR_{max} between the different games was - with only few exceptions - much lower as compared to inter-individual variation in % HR_{max} . Intra-individual variation in % HR_{max} is probably mainly due to opponent- or tactic-depending adaptations of individual moving behaviours. In contrast, inter-individual variation in % HR_{max} is probably mainly due to the underlying aerobic performance of each single player, when the number of players who actively play is quite small and all players participate in handball-specific team-tactical movements like in this investigation. This is strongly supported by our finding of a highly significant negative correlation between v_4 and % HR_{max} . Therefore, individual cardiopulmonary demands during handball matches are the lower, the better developed aerobic performance of each individual player is. Although no data on the association between further handball-relevant performance characteristics like goal effectiveness and rate of technical mistakes are available so far, it is very probable that these correlations to aerobic performance also exists. The more tired a player gets, the higher the quote of technical mistakes of this player (Platen 1989).

Conclusion

Cardiopulmonary demands were very high in all players in all matches. We could demonstrate for the first time in team sports that individual load during a highly demanding tournament was the higher the worse developed basic endurance capacity (v_4) was. This is a strong indicator for the necessity of the development of a high aerobic capacity in international female top level handball.

WHICH MOTOR ABILITIES HAVE THE HIGHEST IMPACT ON COMPETITIVE PERFORMANCE OF SLOVENIAN HANDBALL GOALKEEPERS?

Maja PORI, Igor JUSTIN, Tanja KAJTNA, Primož PORI

Faculty of Sport, University of Ljubljana, Ljubljana, Slovenia

Summary

The objective of the research was to find a correlation between motor abilities and competitive efficiency of Slovenian handball goalkeepers. The subject consisted of 46 male goalkeepers, members of first and second Slovenian handball league clubs. The results show that goalkeepers, who were able to express higher level of explosive strength of arms appeared to be more effective in the game of team handball.

Keywords: *handball goalkeepers, motor abilities, performance*

Introduction

Playing positions and roles in team handball are divided on the basis of skills, abilities and characteristics of the players (Šibila, 2004). The most specific playing position in team handball is a position of a goalkeeper. His basic activity is saving opponent's shots in the goalkeeper's area. There is a lack of literature concerning analyzing motor abilities of goalkeepers in correlation with their competitive performance. Most researches concentrated on analyzing the differences between handball players of different playing positions.

Many researchers found out that playing positions differed from one another most in anthropometric characteristics (Chaouachi, Brughelli, Levin, Boudhina, Cronin and Chamari, 2009; Šibila in Pori, 2009; Sporiš, Vuleta, Vuleta and Milanović, 2010; Milanese, Piscitelli, Lampis and Zancanaro, 2011). Available literature includes some sources that discuss the specific role of the goalkeeper from the aspects of motor abilities for this playing position (Gruić and Vuleta, 2009; Sporiš et al., 2010). Some researchers concluded that abilities between positions in elite handball players appear to be very similar, with the abilities of specific agility and explosiveness having the highest impact on players' performance in general (Chaouachi et al., 2009). The other analysis showed that goalkeepers underperformed in all motor abilities compared to players of other positions (Christodoulidis et al., 2009).

All the playing positions demand high developed motor abilities, which are specific for each playing position. Probably it's due to the fact that differences occur in the volume and intensity of large-scale cyclic movements and the frequency of acyclic activities for players in different playing positions (Šibila, Vuleta and Pori, 2004). Competitive team handball requires muscle strength, speed and endurance (Marques, 2010). In the process of selection the goalkeepers are usually recruited on the basis of increased height, weight, poor motor skills or on the desire of children for playing the role (Šibila, Pori and Imperl, 2008). To achieve good competition performance, goalkeeper should express high level of many motor abilities (Šibila et al., 2008). In the present study we concentrated on strength, coordination (agility) and flexibility.

Strength can be defined as the ability of a muscle group to exert a maximal force in a single voluntary contraction (Knapik, Sharp, Darakjy, Jones, Hauret and Jones, 2006). One of its subcomponents could be named power, which is characterised with tests that involve rapidly projecting objects or the entire body in a single voluntary effort (Knapik, et al., 2006). As goalkeepers do many movement of that kind (quick starts, sudden jumps, short sprints...) we could expect some correlation between strength and competition efficiency. In our study there are 5 tests measuring that ability, which could also be called explosive strength (Santtila, Kyrolainen and Hakkinen, 2009). Subjects whose explosive strength of legs is on higher level are probably more efficient in performing those sorts of movements (Pori, Tušak and Pori, 2009).

The coordination shows the ability of efficient resolution of space-related problems, which gives the goalkeeper the ability to respond quickly to incoming shots. Saving shots demands the activation of the entire body and represents a combination of complex motor structures performed with maximum speed. One of the basic movements that dominantly participate in goalkeeper's situational activity is side-stepping (Rogulj and Papić, 2005). Well coordinated movements could also reflect in rational technique (Malacko, 2000; Šibila et al., 2008).

Flexibility is mostly explained as ability of performing movements of maximal amplitude. In team handball the optimal level of flexibility implies either the possibility of maximal manifestation of other motor abilities or the improvement of technical performance of elements that can assure an advantage over one's opponent (Gruić, Ohnjec and Vuleta, 2011). In addition higher level of flexibility could not just contribute to better competition performance but also as prevention from injuries (Rubini, Costa and Gomes, 2007). Flexibility is also important for attaining high physical fitness level (American College of Sports Medicine, 1998; Žak and Sterkowicz, 2006).

The evaluation of the handball goalkeeper performance is normally made considering only the balls received in relation with the balls saved by this player (Prudente, Garganta and Anguera, 2010). When saving the ball the goalkeeper performs many actions such as moving to the left and right side anticipating the ball location, moving to the front, jumping, getting down, lifting arms and legs... which require certain level of motor abilities. The aim of the present study was to analyse which motor abilities correlate most with competition performance of Slovenian handball goalkeepers.

Methods

Participants

The subject consisted of 46 male goalkeepers, who were members of first and second Slovenian handball league clubs (age: $24,2 \pm 5,2$ years, height: $185,6 \pm 4,9$ cm, body weight: $88,2 \pm 9,6$ kg). The sample represents 63% of the whole population of Slovene elite handball goalkeepers.

Variables

Motor abilities were measured with 7 motor tests, assessing the level of strength, coordination (agility) and flexibility. We have used following tests: heavy ball throw test (HBT), standing long jump test (SLJ), squat jump (SJ), counter movement jump (CMJ), drop jump (DJ), stepping sideways (SS) and hip abduction (HA). Independent handball professionals evaluated competitive efficiency (CE) of goalkeepers, using values from 1(very bad) to 5 (excellent). They evaluated the goalkeepers technique and currently competitive performance. The average values of both represent the competitive performance in general.

Statistical methods

The SPSS statistical package was used for statistical data analyses. The concordance of experts values was calculated using Kendall's coefficient of concordance (W). Basic statistics for variables were computed. The correlation between motor abilities and competitive efficiency was assessed with the Pearson's correlation coefficient. A probability level of 0.05 or less was taken to indicate statistical significance.

Results and Discussion

Basic statistical characteristics of variables are presented in Table 1. The Kendall's coefficient (W) was statistically significant ($p=0,01^{**}$).

Table 1. *Basics statistical characteristics of all variables*

Variable	Unit	X	SD
Heavy ball throw (HBT)	m	23,62	3,25
Standing long jump (SLJ)	cm	244,95	15,48
Squat jump (SJ)	cm	33,52	3,58
Counter movement jump (CMJ)	cm	35,70	3,35
Drop jump (DJ)	cm	33,20	5,41
Stepping sideways (SS)	second	7,80	0,46
Hip abduction (HA)	degree	66,11	10,53
Competitive efficiency (CE)	point	3,41	1,18

Key: X - average value; SD - standard deviation

The strength of arms seems to have the highest impact on competitive efficiency in our case (Table 2). Only heavy ball throw test (HBT), measuring explosive arm strength, correlated statistically significant with competitive performance ($p=0,00$).

Table 2. *Correlation of all variables*

Variable	HBT	SLJ	SJ	CMJ	DJ	SS	HA
Heavy ball throw (HBT)	1						
Standing long jump (SLJ)	0,32*	1					
Squat jump (SJ)	0,24	0,37*	1				
Counter movement jump (CMJ)	0,23	0,50**	0,70**	1			
Drop jump (DJ)	0,06	0,52**	0,47**	0,55**	1		
Side stepping (SS)	-0,25	-0,31*	-0,23	-0,27	-0,30*	1	
Hip abduction (HA)	0,06	0,36*	0,03	0,23	0,28	-0,23	1
Competitive efficiency (CE)	0,50**	0,15	0,16	0,02	0,09	-0,10	0,06

Key: * $p \leq 0,05$; ** $p \leq 0,01$

Goalkeepers who could express arm movements of high intensity appear to have greater competitive efficiency. Throwing of handball is the type of task which demands a maximal force exertion, as measured in HBT. Goalkeeper has an important role also when he acts outside his area. Most often this is seen at the beginning of a counter-attack, when he has to pass the ball to the best positioned team mate in the court (Šibila, Justin, Pori, Kajtna and Pori, 2010). Throwing skill is one of the most important skill in handball (van Muijen, Joris, Kemper and Schenau, 1991). It is crucial not just for shots against goal but also for long passes (Skoufas, Stefanidis, Michailidis, Hatzikotoulas, Kotzamanidou and Bassa, 2003). Goalkeepers with high level of arm strength could throw the ball with higher velocity, which could lead to faster attack to the opponent's goal. It has been found out that muscle strength has greater influence on ball velocity (van Muijen et al., 1991). There is a lack of literature which could support our results. Šibila et al. (2010) found out that only results in HBT test significantly distinguish elite goalkeepers from low level ones. From these results we could only assume that explosive strength of arms contribute to better competitive performance.

SLJ test involves propelling the body forward as far as possible. It measures explosive strength (power) of legs, which is important when one needs to move quickly. Similar action, just in vertical direction was performed in SJ, CMJ and DJ tests. When performing SJ test the performer is to jump as high as possible from the position where knees are bended at 90 degrees, in CMJ test it is required to start with straight legs and performing a natural flexion before takeoff. In DJ test the performer drops down from a specified height (45 cm) and then jumps immediately upwards as high as possible. As similar kinds of activities (jumps) are common among handball goalkeepers it was expected to obtain higher correlation with competitive efficiency. The results in all mentioned leg strength tests were represented only with the measured length (in SLJ) or height (in SJ, CMJ and DJ) in cm. When defending the goal it is very important not just how far the goalkeeper jumps but even more how fast he can develop the maximum force. Rapid movements of body and body parts are important in shot saving. If a one goalkeeper is able to develop the maximum force quickly, meaning to project the entire body in the direction of the shot, he could be more successful than the one, who actually jumps the same length o height but with slower maximum force developing.

In the side stepping test subject has to move sideways quickly on a distance of 6 m (4 times). Coordinated movement of maximum performed at maximum speed is required. Side stepping test represent the kind of movement which applied during the defense of shots from longer distances. It is most common movement used by goalkeepers to save the ball (Guitierrez-Davila, Rojas, Ortega, Campos and Parraga, 2011). When defending the goal using that kind of movement there is a rapid velocity increase in the final phase of movement (before saving the shot), what is caused by lower leg extension and the contraction of the muscles of the frontal side of the thigh (Rogulj and Papić, 2005). We expected high correlation with the competitive performance but it didn't show in our case. There was also no significant correlation between flexibility test and competitive performance. Only the results of Šibila et al. (2010) could in some way support our findings. There was no difference in results in agility or flexibility tests between goalkeepers of different competition level. While we didn't find any other significant correlation between the motor tests and competitive efficiency, it could be possible that this abilities are on similar level by all subjects and the tests did not have high sensitivity to predict the level of performance. It could not be concluded that this abilities aren't important for goalkeepers, it just didn't distinguish between more and less successful goalkeepers in our case.

Conclusions

Data concerning handball player's position-related model characteristics are very important from the aspect of achieving the elite results. This information contributes towards understanding specificity of individual playing positions and consequently leads to more precise selection of the players and planning of the training process. Programs are target orientated towards the abilities which show the highest influence on success of handball goalkeeper. The results of the present study show that only certain level of arm explosive strength is important for competitive efficiency of handball goalkeepers. As there was no other motor ability correlating with competitive efficiency, it could be concluded that goalkeepers express similar level of those abilities. It should not mean that those are of no importance for goalkeepers' performance. Top level goalkeepers should have high level of their motor abilities so gained information could be of use for further individualization and careful planning of training process. The specific playing position of goalkeeper require special training and it should not be neglected in the favour to other positions.

maja.pori@fsp.uni-lj.si

EFFECT OF LEARNING ON THE CHANGE OF THE BALL VELOCITY OF THE SET SHOT IN THE TEAM HANDBALL

Primož PORI, Vesna SKAZA, Marta BON, Marko ŠIBILA, Igor ŠTIRN

Faculty of Sport, Ljubljana, Slovenia

Summary

The primary purpose of this study was to analyze the effect of learning on the change of the ball velocity of the set shot (shot from the ground) in the Team handball. We found out that the learning process significantly affects the rate of ejection of the ball of analyzed shots by the female students as well as male students. We demonstrated that even relatively short transformative process of learning motor skills in handball, provides positive effects on quality of set shot performance in the Team handball.

Keywords: *Team handball, Set shot, Learning, Ball velocity, Radar*

Introduction

All activities in the Team handball are performed in specific conditions, characterized by the presence of players of the opposing team and obligation to playing regulations. Selection and execution of activities therefore depends mostly on various situations in a match (Šibila, 2004). One of the most important elements that define the successfulness of a team and an individual player is shot efficiency.

One of the basic and probably the most typical shot among various shooting techniques used in the team handball is the Set shot (SS). Like the most types of shots it is driven by ballistic muscle contraction (Enoka, 1998). This type of muscle contraction is performed with maximal velocity and acceleration which results in brief contraction times and high rates of force development. The Set shot (SS) is also determined by a proximal-to-distal principle which describes progressive contribution of the body segments to the momentum of the ball, beginning from the base of support and progressing through the pelvis, trunk, shoulder and elbow to the hand (Marshall, & Elliot, 2000). There should also be an optimal delay between the activation of the more distal muscle corresponding to the more proximal one in order to gain the highest final velocity of the ball at release.

The requirements described above are fulfilled when the proper throwing technique is applied. Therefore learning process consisted of the theoretical explanation of the throwing technique as well as practical demonstration and practise of the set shot should improve performance of the shot. According to Gentile (1987) the motor learning is composed of two stages. In the first stage the learner gets the overall information and an idea of the movement while in the second stage the learner has to adapt to the new movement pattern, to increase consistency in achieving the goal of the skill and finally to perform the skill efficiently.

The aim of the study was to investigate the influence of the learning process on the maximal velocity of the ball.

Methods

Participants

73 male students participated in the experiment (average age 21.4 ± 2 , average height 180.1 ± 5.4 , average body mass 77.8 ± 7) and 50 female students (average age 21.1 ± 2.1 , average height 165.4 ± 6.2 , average body mass 59.1 ± 7.4). All students were attending classes on Theory and methodic of Handball in the school year 2009/2010 that was given twice per week for three school hours. All the students were in good health at the time when the tests were given and have personally volunteered to take part in the tests.

Instruments

In order to precisely determine the appropriate characteristics of the pattern, we used the age and basic anthropometric measurements of the students (body weight and body height). The basic, preliminary variable was the velocity of the ball performed with the dominant hand in Set shot (SS). To measure the velocity of the ball in the SS, Stalker ATS Professional Sports (Applied Concepts, Inc., USA) radar was used that was placed seven meter from the shooter and at the height of 150 cm. We measured the highest speed of the ball in kilometer per hour (km/h). For the measurements and learning processes of handball elements, the ball volume between 54 and 56 cm was used and the mass (weight) between 0,375 kg and 0,400 kg. Besides controlling and measuring the ball velocity, we invited three independent assessors that were asked to give their evaluation on technical quality of the set shot, using five level grade in order to give precise evaluation (1 – very bad, 5 – excellent).

Procedures

Experiment took part within regular pedagogic process at our Faculty (Pori in Šibila, 2009). It consisted of 20 sessions which were executed twice a week for 10 weeks. The teaching program was divided into two parts. In the first part which lasted for 8 working sessions (4 weeks) the basic information of the SS and handball in general were delivered to the students. In the second part which lasted for 6 weeks, students additionally to the regular pedagogic process performed the set shot training. The training was programmed to progressively increase the numbers of executed shots as shown in table 1.

Table 1: Programming on additional training of SS

Week/Number of sessions per week	Repetitions /Number of sessions per week
Week 5/2	10/2
Week 6/2	15/2
Week 7/2	18/2
Week 8/2	15/2
Week 9/2	18/2
Week 10/2	20/2
Total:	192

The measurements were executed three times: before the first lesson, after the first part of the experiment and at the end of experiment. The measurements consisted of measuring velocity of the ball and grading the shot technique by three experts.

To determine statistically significant differences between the assessments of quality of performance as well as to identify differences in the ball velocity, we used the method of repeated measurements.

Results

Figure 1 shows average results of the ball velocity when set shot is done. Both groups (male and female students) showed average progress according to the measurements.

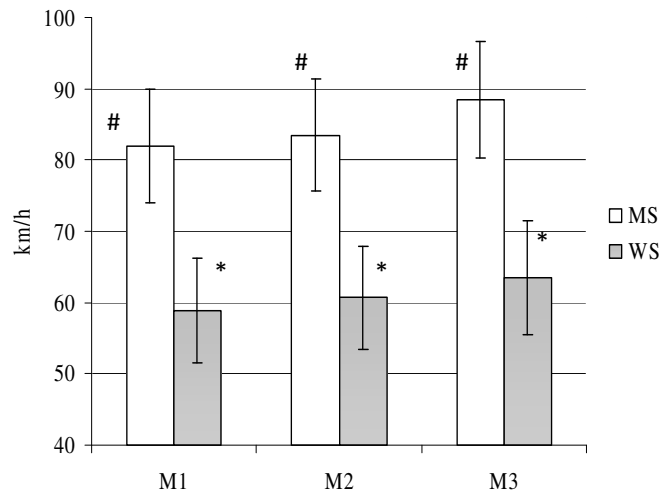

Key: **MS** – Men students; **WS** – Woman students; **M1, M2, M3** – Measurement 1-3;
 #81,9<83,5<88,4 ($p<0,05$); *58,9<60,7<63,5 ($p<0,05$)

Figure 1: Average results of the ball velocity at three repeated measurements

Amongst first and second measurement (M1) in (M2) the students managed to increase in average the ball velocity for 1,6 km/h which is slightly less than female students, their average was 1,8 km/h. Greater progress of male students is seen between second and third measurement where the average ball velocity rose from (M2) in (M3) 83,5±7,8 km/h to 88,4±8,2 km/h (the difference in average being 4,9 km/h). Comparing to female students the difference in progress amongst M2 and M3 came to 2,8 km/h average. The differences of the ball velocity noticed in all the measurements are statistical significant for male and female students. (See Figure 1).

The evaluation marks of technical quality of the SS showed progress in both, male and female students (Figure 2). Lower average evaluation grade (M1) was seen in female students (2,6±0,7) whereas in male students (2,9±0,8).

Greater progress amongst M1 and M2 is noticed in female students (0,7) whereas with male students (0,5). In the last measurement, the average evaluation of set shot (M3) was 3,9±0,6 and was slightly higher than comparing to female students. All the differences noticed amongst measurements are statistical significant for both male and female students (see Figure 2).

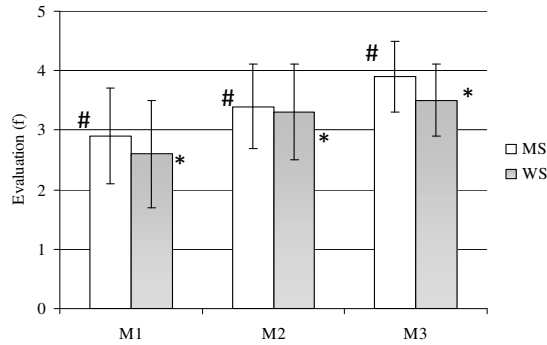

Key: *MS* – Male students; *WS* – Female students; *M1, M2, M3* – Measurement 1-3;
 #2,9<3,4<3,9 ($p<0,05$); *2,6<3,3<3,5 ($p<0,05$)

Figure 2: Average results of measurements given by three independent assessors

Discussion

The purpose of this study was to evaluate the increase of the velocity of the ball of the set shot which was induced by the teaching intervention. The results showed significant increase of ball velocity both after the first and after the second part of the experiment; however some differences in the range of changes between male and female students were obtained. The changes of velocities were well supported by the evaluation grades of throwing technique given by three independent experts.

The obtained ball velocities are consistent with previous research (Tillaar,& Ettema, 2007; Fradet, Botcazou, Durocher, Cretual, Multon, Prioux, & Delamarche, 2004; Wagner et.al, 2010), however it must be noticed that we used the ball size 2, which is commonly used for the education process at our institution.

The average increase of the ball velocity after the first part of the experiment was small (1.6 km/h and 1.8km/h for female and male students respectively) but consistent, therefore significant differences were obtained. Nevertheless the increase was small this means that almost all students threw the ball faster after the first part of experiment and only a few obtained poorer result. The reason that female students on average obtained poorer initial results (ball velocity and grade of technical performance) is probably of the social nature. Perhaps male students gained more throwing experience in their life with respect to female ones, because of different nature of their childhood play and interests. Because of lower initial technical knowledge it is possible that female students gained greater improvement after the first (teaching) part of the experiment. On the other hand greater motivation to improve technical skill and to achieve great ball velocities, which led to more enthusiast approach to training, could be the reasons that male students gained greater increases in ball velocities after the second (training) part of the experiment. In general, greater increases of ball velocities were obtained after the second part of the experiment with respect to the first one. This finding corroborates with the general statement that learning process must be upgraded with the sufficient amount of drill (Schmidt, & Wrisberg, 2008).

Conclusion

Our results showed that both teaching and training intervention caused improvements in technical performance and measured ball velocities for both male and female students.

 primoz.pori@fsp.uni-lj.si

THE INFLUENCE OF FEEDBACK ON THE CHANGE OF THE BALL VELOCITY OF THE SET SHOT IN THE TEAM HANDBALL

Primož PORI, Igor ŠTIRN, Marija JELER, Marta BON, Marko ŠIBILA

Faculty of Sport, Ljubljana, Slovenia

Summary

Set shots are the most basic shots in the Team handball. In the present studies, we are interested in the ball velocity in the ejection phase in the conditions of the external influence in the form of feedback. The results showed that male students are prone to feedback from the radar, which can be associated with increased motivation to exercise. During training process, feedback from the radar could be valuable motivational tool for students.

Keywords: *Team handball, set shot, feedback, ball velocity, radar*

Introduction

In all types of shots it is very important that different body parts are included into action in a proper time sequence thus enabling maximum speed and control over all parts of the body. The same holds true for the Set shot (SS), one of the basic shots in handball. It is supposed to be the easiest to learn for beginners, but for professional handball players it is indispensable, especially when shooting from far. The basic technique in SS is divided into two stages; the preparation and the ejection phase (Šibila, 2004).

The major biomechanical factor enables all types of shots is the quality of transmission of impulses from the lower to upper body parts (pelvis, shoulders, elbow, wrist and ball). Velocity in single joints has to increase stepwise. In the course of a shot, therefore, the highest velocity should be reached first in a pelvis and later in a shoulder, first in a shoulder and then in an elbow, etc. The rotation of segments should follow one another in precise such order when shooting. Proximal segments should commence prior to distal segments with the rotation (Enoka, 1998). Proximal-to-distal principle is described as a synchronized movement in the joints and body, starting with the trunk and finishing off on the extremities (Marshall, & Elliot, 2000). The result of such principal (proximal-to-distal) is the velocity of the ball that reaches its peak at the last stage of the ejection (Hong, Cheung, Roberts, 2001).

In the process of training different approaches and methods are used in order to improve the velocity of the ball when shooting (Carter, Kaminski, Douex, Knight, & Richards, 2007). Mostly, they are closely tied to the specific development of physical abilities such as strength, speed and coordination. The basic aim of the present study was to see, whether the velocity of the ball could be increased if external stimulus is included. In our particular case, we used radar to get feedback information. We did foresee that the effects of such trainings would show higher motivation, therefore shots towards a goal being more forceful.

Methods

Participants

All examinees (male students) attended classes on Theory and methodic of Handball in the school year 2009/2010 that was given twice per week for three school hours. Male experimental group comprised of 38 examinees (average age $21,6 \pm 2,1$ yrs; average body height $179,9 \pm 5,8$ cm; average body mass; $79,4 \pm 7,4$ kg), the control group of 35 examinees (average age $21,2 \pm 2,0$ yrs; average body height $181,2 \pm 5,1$ cm; average body mass; $76,0 \pm 7,1$ kg). All the examinees were in good health at the time when the tests were given and have personally volunteered to take part in the tests.

Instruments

In order to precisely determine the appropriate characteristics of the analyzed sample, we used the age and basic anthropometric measurements of the students (body weight and body height). In the sample of variables three varieties of SS were incorporated (Table 1).

Table 1: Set shot (SS) varieties

	Key	Variable	Unit
1	MHZ	Set shot with a dominant arm	km/h
2	MHM	Set shot with heavy ball with dominant arm	km/h
3	MHS	Set shot with a non dominant arm	km/h

To measure the velocity of the ball in the SS, Stalker ATS Professional Sports (Applied Concepts, Inc., USA) radar was used that was placed seven meter from the shooter and at the height of 150 cm. We measured the highest speed of the ball in kilometer per hour (km/h). For the measurements and learning processes of handball elements, the ball volume between 54 and 56 cm was used and the mass (weight) between 0,375 kg and 0,400 kg.

Procedures

Experiment took part within regular pedagogic process at our Faculty (Pori in Šibila, 2009). It consisted of 20 sessions which were executed twice a week for 10 weeks. The measurements were executed three times: before the first lesson, after the first part of the experiment and at the end of experiment.

The teaching program was divided into two parts. In the first part which lasted for 8 working sessions (4 weeks) the basic information of the SS and handball in general were delivered to the students. In the second part which lasted for 6 weeks (12 working sessions), students additionally to the regular pedagogic process performed the set shot training. The training was programmed to progressively increase the numbers of executed shots as shown in the Table 2. At that time of experiment we divided the students in two groups, control group and experimental group.

During the additional training the experimental group carried out strikes against the empty handball door, behind which the radar was placed. The radar was transmitting the velocity of the ball to the shooter.

Table 2: Planning on additional set shot training

Week/Number of sessions per week	Repetitions /Number of sessions per week
Week 5/2	10/2
Week 6/2	15/2
Week 7/2	18/2
Week 8/2	15/2
Week 9/2	18/2
Week 10/2	20/2
Total:	192

The output data of ball velocities was processed by selected methods of descriptive statistics. The differences between the arithmetical mean values of results of the chosen variables were tested with the use of repeated measurement method. Statistically significant differences were accepted with 5% statistical significance threshold (two-tailed testing).

Results

Figure 1 shows the average velocity of the ball in three varieties of SS (MHŽ, MHM, and MHS) from the 1st and 2nd measurement. It is evident that in all three measurements, the velocity of the ball increased in the 2nd measurement. The results show that the velocity of the ball ejection in MHŽ increased by 1,4 km/h; in MHM by 0,7 km/h and in MHS by 2 km/h. The differences amongst 1st and 2nd measurements are typical at all variables (Figure 1).

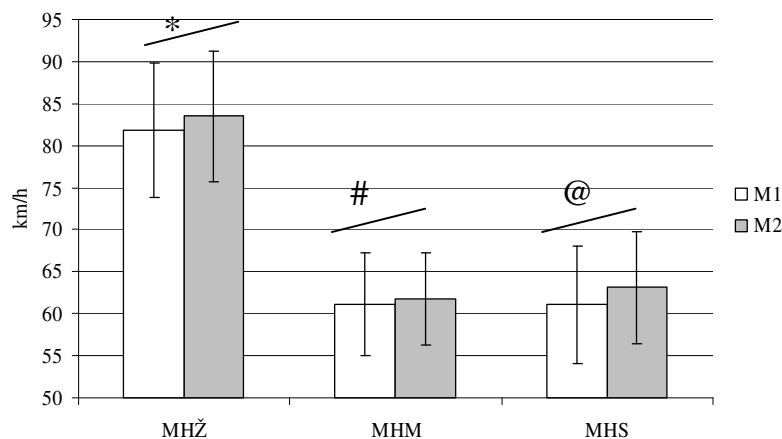

Key: **M1, M2**– the 1st and the 2nd measurement; **MHŽ** – SS with dominant arm; **MHM** – SS with heavy ball with non dominant arm; **MHS** – SS with non dominant arm.

*81, 9<83, 5; # 61, 1<61, 8 in @ 61, 1<63, 1; (p<0, 05)

Figure 1. Average ball velocity at 1st and 2nd measurement; three varieties of SS.

Figure 2 demonstrates average velocity of the ball ejection in all three varieties of SS for groups, control and experimental (MHŽ, MHM, MHS). At all three variables the examinees showed progress in the velocity of the ball ejection. The greatest progress is noticed in Set shots when dominant arm is used (MHŽ). In the experimental group the average velocity of the ejection improved by 6, 9 km/h, whereas in control group by 2, 9 km/h. Even the repeated measurements showed statistically significant differences ($p < 0, 05$).

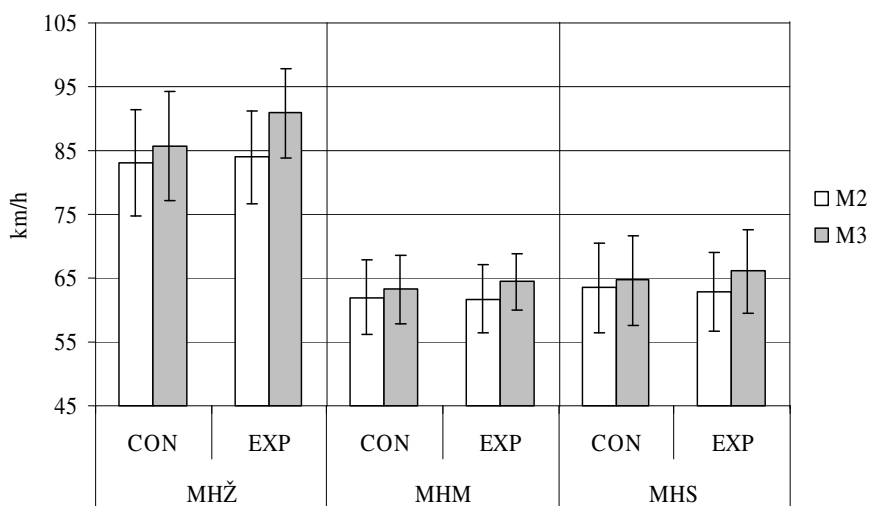

Key: **M2, M3**– the 2nd and the 3rd measurement; **MHŽ** – SS with dominant arm; **MHM** – SS with heavy ball with non dominant arm; **MHS** – SS with non dominant arm; **CON** – Control group; **EXP** – Experimental group.

$MHŽ/EXP - 84,0 < 90,9$ ($p < 0,05$); $MHŽ/CON - 83,0 < 85,8$ ($p < 0,05$); $MHM/EXP - 61,7 < 64,4$ ($p < 0,05$); $MHM/CON - 61,9 < 63,3$ ($p < 0,05$.); $MHS/EXP - 62,8 < 66,1$ ($p < 0,05$); $MHS/CON - 63,5 < 64,7$ ($p < 0,05$).

Figure 2. Average ball velocity at the 2nd and 3rd measurement of both groups in three SS varieties

Statistically significant differences in progress of the velocity of the ball ejection amongst 2nd and 3rd measurement were seen when training Set shot using a heavy ball and a dominant arm (MHM). The radar confirmed that the experimental group improved its result by 2,7 km/h, control group by 1,4 km/h. Similar results are noticed with Set shot when a non dominant arm is used (MHS), where the average ball velocity of experimental group increased from 62,8±6,2 km/h to 66,1±6,6 km/h. The control group (1,2 km/h) compared to experimental group (3,3 km/h) showed lower progress.

Discussion

In present study we were interested in the ball velocity in the ejection phase in the conditions of the external influence in the form of feedback. The results of the analyses done, confirmed that the experimental group of students, who had trained under the influence of external stimulus, showed greater progress than the control group at all varieties SS (MHŽ, MHM, MHS).

Wagner, Buchecker, Duvillard, and Muller (2010) did the analyses of elite and recreational handball players and came to the conclusion that the velocity of the ball is the top most important factor contributing to the success of shooting towards the goal. However, various means and

methods can effect the change of the velocity of the ball. Research results showed that in sports like handball, baseball, water polo and other, the researchers checked how different strength trainings influence the improvement of the ball ejection. Carter et.al, (2007) came to the conclusion that a combined plyometric trainings using a heavy ball for upper body parts influence better ejection of a baseball. However, the research Escamilla, Speer, Fleisig, Barrentine, & Andrews (2000) determined that trainings with lighter and heavier baseballs improve the velocity of the ejection of a classical ball. Last but not least, one of the latest researches shows (Sudan, 2009) that with the maximum load and ballistic trainings for upper body parts influence the throw speed (ejection) with female professional handball players.

The statement by Van den Tillaar (2003) saying that at the beginning stage, learning the techniques gives much more progress and later starts decreasing gradually, is partly true. This was perfectly seen in the control group where due to the six week trainings of shooting towards a goal, we did not see much progress comparing to the progress achieved when training and learning the basics of handball in a 4 week period. After six weeks we realized that male control group achieved greater growth of ball ejection comparing to the growth in the first part of the experiment (MHŽ=2,7 km/h, MHM=1,4 km/h, MHS=1,2 km/h)

In other accessible researches, the velocity of the ball ejection was slightly lower, comparing to the results in our pattern. Van den Tillaar and Ettema (2007) did a three dimensional analyses of SS testing professional handball players. The average velocity reached up to 21, 55 m/s. We got similar results in other researches (Fradet, Botcazou, Durocher, Cretual, Multon, Prioux, & Delamarche, 2004; Wagner et.al, 2010); the main reason for such results owing to the weight of the ball (Size 2; weight from 0,375 kg to 0,400 kg). The decision to use a lighter ball was taken due to the fact that our examinees were beginners and we wished to present the basic handball elements in a pleasant and less complicated way. In all our other studies we used the ball Size 2 weighing from 0,425 up to 0,475 kg.

Conclusion

During training process, feedback from the radar could be a valuable motivational tool for students.

primoz.pori@fsp.uni-lj.si

ANALYSIS OF TACTICS AND OFFENSIVE PLAY SYSTEMS AT THE EUROPEAN ELITE TEAMS IN ORDER TO OPTIMIZE THE ATTACK OF THE ROMANIAN “TOP” TEAMS - MEN’S HANDBALL

Dr. Rudi Ioan PRISACARU

National University of Physical Education and Sport, Bucharest, Romania

SUMMARY

The research falls into the process of performance capacity optimization through the technical and tactical component seen by the application of offensive play systems against different collective defense structures and approach of attack against defenses under retreat and reorganization. We focussed on the team actions from a tactical point of view, in other words, how they are developed between the beginning and the end of a game phase, considering the ratio of opposition between many teams.

Keywords: handball, high performance, tactics, playing systems, attack.

INTRODUCTION

The handball game can be analyzed in terms of numerous criteria focused on the factorial profile of optimizing the sports performance.

The aim of our study is to analyze the playing actions of the current high performance handball and to take out the collective tactical benchmarks on the attack playing compartment; identification of characteristics and development trends of these elements in the Europe’s elite and their implementation/proposal within the local playing concept.

Nowadays, the Romanian high performance handball is below the results obtained during the glory years of 1960-1970. The world champion’s titles along with the Olympic medals and winning of the European cups had made of the Romanian handball school a nation worthy to be followed by many countries. In the current large-scale international competitions, teams like France and Spain well below the Romanian teams of that time, became the most powerful nations. How did these teams climb the world’s elite? With what? With whom? By what? These are questions that often ask the Romanian coaches, players and even specialists in different branches of sport.

The decrease in the value results found in recent years at the Romanian teams participating in major international competitions cannot be explained only by a simple factor. *The performance in the collective sport game is reflected by a series of inter-relational components, located in the middle of a complex universe.*

Within this context, by the nature (theme) of our research, we tried to explain (to some extent) the results decrease in the high performance handball teams of Romania and to propose an update of some elements components of the local playing concept which remained at an “academic” level.

The research **objectives** are:

- The perception of attack playing systems and tactics trends by identifying the collective tactical behavioural constants of the team in running system attack and at times when the ball is crossing from defence to attack;
- Comparison of tactical playing pattern elements found in the European elite teams and Romanian top teams evolving in the period studied at the European highest competitive level;
- Highlighting and presentation of differences / similarities which may exist between the teams studied in the development of the collective tactical behaviour in the offensive playing sectors level: system attack and fast play.

Regarding the **premises-issues**, Popescu C., (1996) envisages *the use of multiple playing systems in the attack, in alternation during a match or even within the same phase of the game for opponent defensive organizations disturbance.*

In the same context, Grehaigne J-F., Fayol, M., (1989) points out that *“innovations, changes made by a team or coach in how to play or develop the playing systems, when effective, are always adapted later (with some small differences) by most other teams. Thus, players can change or increase their playing level by adopting a certain behaviour based on the common playing plan”.*

From the beginning our **questions** were formulated as follows:

- In addition to individual characteristics of the players at disposal, is there a constancy in the way of using the systems and forms of attack in the high performance handball game?
- Are there some attack systems used mainly against certain defensive organizations?
- Is the way of developing these playing systems different to European elite teams compared to the Romanian top ones?
- Which are the characteristics of collective tactical behaviour in the attack showed by these teams?
- To what extent and how the Continental elite teams and Romanian top ones ensure the best running of the ball crossing from defence to attack moments?

The research **hypotheses** were set as follows:

➤ Streamlining and creative standardizing of the collective action techniques are priority elements in the development and optimization of the attack at the European elite teams, compared with Romanian top teams.

➤ Team collective actions underlie the development and optimization of the system attack by the European elite teams, tactical behavioural aspect different from the one of the Romanian top teams.

➤ Tactical vision based equally on the fast playing induces the growth of players' optimal completion conditions, compared to system attack.

➤ The tactical pattern updated after the perception of the game trends at the European elite level leads to an improvement / enrichment of the Romanian unitary vision of training and playing.

➤ The method of attack playing systems and tactics assessment leads to actual (relevant) detection of tactical behavioural ways in the game, the diagnosis and objectification of the preparation and competition process.

METHODOLOGICAL SPECIFICATIONS

• Research methods – an empirical and pluridisciplinary approach

Our approach is essentially empirical – data analysis takes precedence – and primarily pluridisciplinary, as the analysis of the *handball game*, part of the field of the *sciences of corporal activities*, is enriched by the contribution of other human sciences (social sciences, the economic, psychological field and law policy).

The research methods approached in the preliminary exploration study and the operational methodological framework are: the method of observation, the comparative method, the method of modelling, experimental methods, the descriptive statistic method, the graphic method, the inferential statistics - *the chi-square test*, the conceptual pattern of construction and verification of hypotheses.

The elaboration of the method whose object is the evaluation of the offensive tactical development and playing systems is based on a series of indicators, such as:

- conceptualization and classification of the assessment elements (for example, “TCA” **Table 1**)
- stating the criteria of identification of the performance technical and tactical behaviour;

- presenting the elements (manners of appreciation) and the conditions of evaluation of the technical and tactical attack actions;
- establishing the conventional signs and elaborating the observation report.

Table 1. Characteristics and classification of the Collective Action Techniques (TCA) in the attack

Collective Action Techniques	Characteristics	Types of tactical actions
Technique “A” (TA)	System attack with 1 pivot, form in semicircle circulation, with the infiltration of 1 player in the middle of defence («mobile pivot»); system attack with 2 pivots, form in semicircle circulation.	Team collectives (ACT)
Technique “B” (TB)	System attack with 1 pivot, form in circulation in front of the defence (encirclements, intersections or sector permutations between the 9 m and/or 6 m line).	
Technique “C” (TC)	System attack with 1 pivot, form in 6 m semicircle circulation in front of the defence at the same time of the game (the penetration of one player in the defence at the same time as the circulation / permutation of players from 9 m and /or 6 m in front of the defence).	
Technique “D” (TD)	System attack with 1 or 2 pivots, positional form based on collaboration in pair of 2-3 players without changing the sector (combinations by keeping attack positions: tackle / leaving from successive tackle, synchronization in “U”, diagonal play with the pivot, etc.).	Collaborative relation between 2-3 players (AR)
Technique “E” (TE)	System attack with 1 pivot or 2 pivots, positional form based on individual action, without a prior offensive preparation based on collective team actions or relational actions of 2-3 players.	Individuals (AI)

- **The subjects and framework of the research:** within the most important continental competitions (*the 2008 European Championship and the 2007-2008 League of European Champions*), six national men’s senior teams were evaluated, namely Denmark, Croatia, France, Germany, Sweden, Spain and 4 champion club teams such as the champion of Spain – Ciudad Real, the champion of Germany – Kiel, the champion of France - H.C. Montpellier and the champion of Sweden – Hammarby. For the Romanian top teams, the national men’s senior team of Romania was analyzed during the competitions that took place between 2007 and 2009 and the champion team of Romania, H.C.M. Constanta (2007 – 2008). For these competitions, 4973 ball possessions were taken into account for all the studied teams.

OPERATIONAL EXPOSURE OF THE RESEARCH STUDY

The operational exposure of the research consisted first in building the elements necessary for the verification of the hypotheses. Consequently, we proceeded to detect the characteristics of the tactical behavioural pattern in the attack at the level of European elite and then at top Romanian level. The third stage, which occurred from the point of view of a comparative analysis (study) of the two team groups, shows whether there are differences with respect to the modern play which is practised by the European elite teams, potential consequences of the tactical alternatives to optimize the attack. In the last stage we shall examine the importance of the system attack and the fast playing of the selected teams.

- **Detecting the ways of tactical action within the system attack – European elite group**

Graphic 1. Proportion of the Collective Action Techniques (TCA) against staged defence (AV) and aligned defence (AL): EUR elite teams

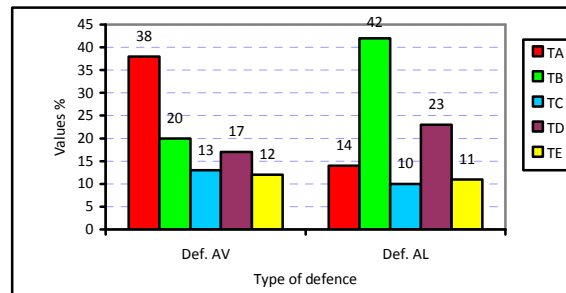

The most important parts of the actions elaborated within **TA** (38%) are statistically significant in the sample (χ^2 : 52; df: 36; significance: 0,04). Using the system with one pivot in the form of semicircle circulation (turning the system into two pivots with a mobile pivot) is most often involved in the tactical offensive activity of European elite teams against advanced defences.

Against aligned defence, the most important parts of the actions elaborated within **TB** (42%) are statistically significant in the sample (χ^2 : 154, df: 36, significance: 0,00). The system with one pivot in the form of circulation / permutation at the 9 m line (without turning into the system with two pivots) is the most used in the activity of the system attack.

- **Tactical behavioural modalities identified in the system attack – Romanian top teams**

Graphic 2. Frequency (proportion) of “TCA” against staged defence (AV) and aligned defence (AL) –Romanian top teams

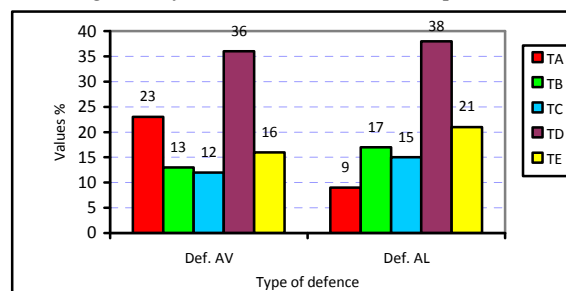

Against advanced and aligned defense, the most important parts of the actions elaborated within **TD** (36% and 38%) are statistically significant in the sample (χ^2 : 10,12; df: 4; significance: 0,04). The use of the one pivot or two pivots system in the positional form (relationships between 2-3 players without circulation at the 6m or 9m line) is most often involved in the offensive tactical activity of the top Romanian teams.

- **Development of the collective team actions (ACT) in comparison with relational and individual tactical actions (AR–AI)**

Graphic 3. Comparison of the values of the EUR elite group and RO top group observed: types of offensive actions (ACT, AR and AI)

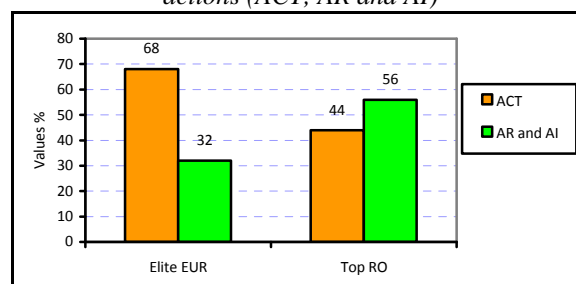

At the level of *European elite group*, the “ACT” number (68%) is statistically significant for the assignment of tactical actions in system attack (χ^2 : 102,9; df: 9; significance: 0,00). The team collective actions are the basis for the tactical vision elaborated by these teams.

As far as the *Romanian top teams*, is concerned the number of ball possessions used through “AR-AI” (56%) is statistically significant for the assignment of tactical actions (χ^2 : 5,59; df: 1; significance: 0,02). The relational actions of 2-3 players as well as individual actions are the basis for the conception of play elaborated by this team group.

- **Examining the elaboration of attack sectors – important (effective) proportion**

Graphic 4. Degree of effective intervention of attack sectors

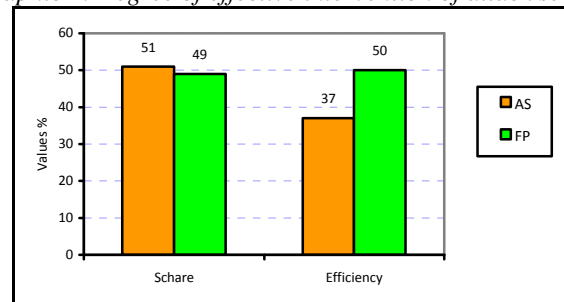

The proportion of the attacks elaborated within the two offensive playing sectors (AS 51% and FP 49%) are not significantly different in the sample from a statistical point of view (χ^2 : 0,73; df:1; significance: 0,39). The use of the system attack (AS) is not often involved in the tactical and strategic activity of the studied handball teams.

The efficiency of the offensive actions elaborated within the two attack sectors (AS 37% and FP 50%) is significantly different in the sample from a statistical point of view (χ^2 : 69,87; df:1; significance: 0,00). The use of the fast play (FP) provides players with more optimal conditions to finish the game in comparison with system attack (AS).

CONCLUSIONS

- **Experimental conclusions**

- The predominance of collective tactical behaviours in the attack detected in the European elite teams concern their constant elaboration *depending on the encountered defence types*. The preferential choice of the *collective action techniques* (“TCA”) proves to be an adequate approach, which enables players to finish the shots in optimal conditions, as a result of an optimal tactical development based on creatively rationalized and standardized modalities of action. At the level of the Romanian top teams, the “TCA” are used irrationally, as the same technique takes precedence irrespective of the type of defence.

- The fact that the European elite teams lay the stress regularly on *collective team actions* determines the players’ satisfaction regarding the increase of their individual and collective abilities. By comparison, the Romanian top teams have a preference for elaborating *relational actions of 2-3 players as well as individual actions* (“AR-AI”).

- Due to the increased efficiency of the sector of *fast playing* (with respect to *system attack*), the tactical pattern at the level of high performance tends to a balance of these playing sectors in attack, by increasing the frequency of the use of the *fast playing*.

- Detecting the modalities of tactical action at the attack level in a developed system by the European elite group contributes to the “reflection” / comparison / completion / optimization of the tactical behavioural modalities at level of the local tactical vision.

- The capacity of tactics and playing systems evaluation method to provide pertinent analysis data, of an evaluative usefulness and an objective “focus” on the collective and individual solicitations (quality of information) influences pertinently the degree of the

training and competition process of users, with respect to the tactical and strategic dimension of the teams.

- **Theoretical and methodological conclusions**

- The theoretical contributions are mobilized from the point of view of the *three inter-comparative spheres* (“TCA”, “ACT” and “AR-AI”, “AS and FP”) of the *tactical dimension and offensive playing systems*, a dimension which is the result of the conjugation and combination of the tactics elaborated in the system attack and the moments when the ball passes from the attack to the defence.

- The results of the analysis of these *three juxtaposed inter-comparative spheres* lead to the proposal of a original conceptual pattern of the tactical dimension and offensive play systems (part of the unitary conception of playing and training).

This conceptual pattern has the following *general requirements*:

- *The use of the team collective actions mainly, the relational and individual ones are used as complements depending on the conditions for the development of the events;*

- *The application of the collective action techniques in a rational and creatively standardized manner specifically mainly of the advanced and aligned defence depending on the perceived opportunities. The attack against staged defence involves mainly the transformation of the one-pivot system into a two pivots system – mobile pivot and against aligned defence the system with one pivot and the form in circulation / permutation of players in front of the defence is used.*

- *The approach of the contrary defensive organizations by revealing their strengths and weaknesses – requirements specific of the respective system or attack sector;*

- *The development of fast playing with the same interest and frequency as the system attack;*

- *The elaboration of the fast playing from the point of view of all its four forms (the primary fast-break; the secondary fast-break; the transition attack; the quick throw of the ball to the centre). This sector becomes an important strategic element in the offensive game optimization and, in the same time, the sector entirely dedicated to the attack game in addition to the one of the system attack.*

- *The method for the evaluation of the tactical behaviour of the team in the attack* was one of the most important methodological contributions brought about by this research. In fact, the study of tactics and offensive playing systems through an adequate way of evaluation of the tactical behavioural modalities can be considered an imperative requirement of *tactical management* (the administration of the tactical dimension) for the technicians of the sporting organizations who are directly involved in the process of training and competition.

In the end, our research provides objective and complementary contributions for our field of sports. They prove the importance of the steps taken in order to update again the elements of the tactical vision, their contribution to the optimization of sporting performance, both for the high performance local teams of which aspire to be the *imperious motor* for the comeback of Romania to the highest level of big competitions and for the European teams which seek continuously to improve their sporting performances and an indispensable adjustment to the evolution of the handball game.

Rudipris@aol.com

INNOVATIVE POSITIONING OF THE GOALKEEPER IN DEFENCE OF SEVEN-METRE PENALTY SHOTS IN HANDBALL

Nenad ROGULJ¹, Vladan PAPIC², Nikola FORETIC¹, Vatomir SRHOJ¹, Marijana ČAVALA¹

University of Split, Faculty of Kinesiology¹, Split – Croatia

Faculty of Electrical Engineering, Mechanical Engineering and Naval Architecture, Split², Croatia

SUMMARY

A goalkeeper must rely on precise positioning and setting. His basic aim is to take the most favourable position, with regard to the characteristics of the shot. This article suggested an innovative mathematical model to calculate the move and the rotation angle in the defence of seven-metre penalty shots which enables maximal body usage as a passive defensive area, the shortest way of body parts in performing defensive movements and equal availability of all the parts of the goal, which, in the end, may result in the higher efficiency in defending penalty shots.

Keywords: *handball, goalkeeper, seven-metre penalty shot, positioning*

INTRODUCTION

The goalkeeper is a player with the biggest influence on the result of his team. The rules of the handball game impose specific technical and tactical performances which are significantly different than in other players in the field. The position he has in the game enables maximum exposure of individual qualities and motor creativity, but also imposes a need for cooperation with his fellow players. Taking into consideration that the goalkeeper's role is specific, his training must sometimes be individualised and differentiated from the rest of the team. Regardless of different styles in defence (Scandinavian, German, ex Yugoslavian) modern defence technique (positioning technique) dominates in top handball today, and it was created as the response to the evolution of handball game concerning emergence of extremely powerful short-distant shots. The basic determinants of this technique, which in the modern handball terms shows the highest level of efficiency, are possession of the optimal spot position, maximal rationalism of defensive movements and complete usage of body as a defensive surface. The goalkeeper's positioning activity is based on two segments: reaching the optimal position in the goalkeeper's area and setting up into an optimal pose in order to achieve maximal efficiency for defending a particular shot. Performance quality of this element directly determines efficiency of the whole goalkeeper's defence because only precise, technically correct and in-time positioning allows rational and fast execution of defensive movements. In the moment when the ball leaves the attacker's hand, the goalkeeper has to position himself on a precisely determined position in the goalkeeper's area. This position must satisfy three basic conditions: equal probability of efficient defending of all parts of the goal frame; maximal usage of the body as a passive defensive area and achieving the shortest trajectory of the body and its parts during a defensive movement. These conditions are fulfilled only when the goalkeeper positions his vertical body axes exactly on the shooting area angle (β_s) symmetrical (Figure 1). This angle is determined with the lines connecting the ball and inner edges of goal-posts. Furthermore, frontal goalkeeper's plane has to be perpendicular to the angle (β_s) symmetrical. Step out distance during defence preparation depends on velocity and morphological characteristics of the goalkeeper and other ones defining positioning activity. However, the step out is recommended to be limited to not being

smaller than the one ensuring that the distance, in which the goalkeeper's horizontal axes is laid, makes an isosceles triangle with lines defined by the ball and the inner edges of goalposts (Co), (Figure 2). Namely, if the goalkeeper is positioned immediately in front of the goal frame, and the shooting angle is smaller than 90° , the angle between the goalkeeper's horizontal axis and the middle of the shooting angle is always bigger than 90° . In this way, the width of the goalkeeper's defending area enlarges as well, so these positions should be avoided. The goalkeeper's playing does not contain many technical elements, but because of the specific function of this player who acts in extreme conditions of time deficit (ball velocity is significantly higher than the velocity of the goalkeeper's defensive movements), the quality of motor skills related to a superbly precise performance of technical elements is the top priority, which means that every single movement has to be performed correctly, rationally, deliberately and precisely. According to the common principle of setting up requiring goalkeeper's frontal plane to be perpendicular towards the shooting direction, it is pretty clear that the defensive movements have to be performed in the frontal plane as well. Any abandonment of this plane from the peripheral parts of the body enlarges the amplitude on which the defensive movement operates and in this way decreases its efficiency. It is not hard to understand that the essence of the goalkeeper's playing consists of adduction and abduction. As the natural motion of the human being is mainly orientated towards the sagittal plane, the group of muscles responsible for realisation of adduction and abduction movements is likely to be less developed. Additionally, motion in frontal plane is more demanding because of the diminished possibility of the imbalance position correction, in contrast to the motion in sagittal plane. Seven-metre penalty shot is a very important part of the handball game and on average there are 3.68 of these in every match (Foretic et al, 2010). It is slightly more frequent in female than in male handball and in relation to the total of scored goals, participates on average with 10 % (Foretic et al, 2010). Defending a penalty shot from seven metres, besides immediately influencing the course of the score, creates a great motivational impact on the team, which makes it even more valuable. Starting with the importance of a seven-metre penalty shot in the final result of the match, the intention of this paper is to analyse basic tactic aspects in the defence of penalty shots and suggest certain improvements of positioning and setting the goalkeeper with the purpose of more efficient defence of these shots.

METHODS

The aim of this work is to suggest an innovative mathematical model to calculate the move and the rotation angle in the defence of seven-metre penalty shots which enables maximal body usage as a passive defensive area, the shortest way of body parts in performing defensive movements and equal availability of all the parts of the goal, which, in the end, may result in the higher efficiency in defending penalty shots. Further on, the aim of the paper is to experimentally check the efficiency of this model in situation-related conditions in defending penalty shots. The calculation of the required parameters of the mathematical model is based on the postulates of flat trigonometry. The experimental check of the efficiency of the model has been done on the sample of 115 seven-metre penalty shots achieved by six players from a club in the Premier league in Croatia and defended by two goalkeepers, potential members of the national team. We analysed the difference in efficiency in defending penalty shots between the usual positioning of the goalkeeper on the horizontal axis at the middle of the goal frame during the defence of one part of penalty shots and innovative positioning with arbitrary detachment and rotation occasionally applied by the goalkeepers. In addition to the number of scored goals and the goalkeepers' defences, we also analysed goal frame misses. The differences have been determined by a non-parametrical HI-square test.

Table 1. Chi-square test (Chi-square-16.87, $p=0.00$, Contingency coefficient=0.36, $p=0.00$, $df=2$)

RESULT	GOALKEEPER		TOTAL
	classical positioning	innovative positioning	
goalkeeper's defence	10 (15%)	16 (32%)	26
goal frame misses	7 (11%)	16 (32%)	23
goal	48 (74%)	18 (36%)	66
total	65	50	115

RESULTS AND DISCUSSION

Situation-related efficiency in the defence of seven-metre penalty shots is about 15% on average (Ohnjec et al 2008) which means the goalkeeper should not carry the burden of defence on his shoulders, but at the same time should not give up in advance and let the attacker be aware of his inferior role. On the contrary, when defending penalty shots with a determined and aggressive attitude and movements, the goalkeeper is suggesting the attacker he has no intention of accepting an inferior position and becoming an observer looking for his mistake, but imposing not only as an equal partner, but as a dominant factor to the shooter. In other words, he will try to bring the shooter into an apparently subordinate position and create an impression of dominance over the space and situation with the purpose of provoking his insecurity while shooting. Nowadays, goalkeepers in top handball most frequently defend in a way to make a longer step out towards the attacker from 2.5 to 4 metres in order to enlarge the potential defensive area. The size of step out is technically limited at four metres by the rule, and functionally by the possibility of lob. On the chosen position, the goalkeeper will apply the potential basic attitude trying to protect most of the goal frame by passive defensive area and by the position of his limbs. Basic aim of this way of defence is to apparently secure maximal surface and to direct defence to the certain part of the goal frame where the attacker is assumed to direct the shot. By a high position and by widely set up raised arms, the goalkeeper will secure upper and middle parts of the goal on both sides, while the lower space next to his free leg is secured by appropriate leg abduction or side-step. Since the goalkeeper can hardly defend the lower space next to his relying leg because he performs side take-off on the same leg or the change of the relying leg, which is technically demanding and slow, it is extremely important to make the right decision which lower space is apparently to be left unprotected. Further on, based on the attacker's activities while preparing the shot and by selective approach, other spaces not likely to be receiving the shot are eliminated as well, thus, in the end, the goalkeeper is focused only to the space where the ball will be directed. If the goalkeeper can identify that space, he will use the leg abduction technique, i.e. arm abduction, and in other case, it is more likely to apply the defence by opening which comprises a larger area. This way of defending is characterised by particularly important shooting fakes by which the shooter is offered certain parts of the goal frame, most frequently with regard to the height. High positioning of arms and even lifting on tip-toes should make the shooter direct the shot into lower parts of the goal frame. If such a shot is directed near the goalkeeper, regarding the arm adduction velocity as an antigravity movement, there is a good possibility to defend a semi-high shot by arms. By a lower and wider positioning, the attacker is forced not to shoot into low or semi-high spaces next to the goalkeeper, but to the higher ones over him or to the space between his legs. A lower shot between his legs is defended by leg adduction, and a high one by arm adduction. By enclosing the semi-high part of the goal frame by abduction of the leg on one side, the attacker could be forced to perform a semi-high shot to the other side which is then defended by the change of relying leg in hops with the abduction of the opposite arm and with adduction of the corresponding arm. By little hops and arm swinging fake or by high positioning, the attacker can be forced to shoot into lower parts of the goal frame to which he can promptly react, and by active movements of legs in lower

and wider positioning, he can make him shoot to higher parts of the goal frame. The goalkeeper has to take into account that players frequently do not shoot immediately, but after one or a few fake swings. It is important to recognize fake swings and not to react to them, but calmly wait for the actual shot, since this can lead to the break of concentration of the player during shooting. By reacting to shooting fake, the goalkeeper is unnecessarily brought into an unbalanced positioning which decreases his chances for situation-related efficiency. The practice, and previous scientific knowledge (Rogulj, 2000), undoubtedly show the goalkeeper has the greatest chances to defend the penalty shot if he performs maximal 4-metre step out provided by the rules. The studies also confirmed (Rogulj, 2000) that a great number of penalty shots, i.e. more than 24% is performed with an accentuated trunk bending to one or the other side and that efficiency is higher in these shots (93,3%) than in the shots performed without the starting ball detachment (78%). However, the practice shows that almost every penalty shot is performed with a certain detachment, i.e. in the moment of shooting, the ball hardly ever lies on the vertical axe of the goal frame middle, which means the inner edges of goal-posts and the ball in the moment of throwing almost never make an isosceles triangle. It is logical to assume goalkeepers are less efficient when defending penalty shots performed with trunk bending from the middle due to incorrect positioning when defending these kinds of penalty shots. Namely, the empirical knowledge show that in defending these shots, goalkeepers most frequently do not respect the basic principle of positioning and do not perform the movement of the vertical axe on the frontal plane in the direction of detachment of the shooter's ball in order to bring their vertical axe on the shooting angle symmetry, but they keep their position on the vertical axe at the middle of the goal frame. Even if they make a certain movement over the frontal plane in the direction of detachment of the shooter's ball, it is most frequently insufficient, keeping at the same time the same angle of the horizontal body axe with relation to the shooting direction, instead of twisting the axe and thus secure its verticality on the shooting direction in the moment of throwing the ball. A goalkeeper's movement (x) and rotation angle (α) depending both on the size of the ball detachment from the middle (L), for the maximal four-metre step out by a goalkeeper, can be easily calculated by these formulas:

$$x = f(L) = \frac{4}{7} \cdot L \quad \text{and} \quad \alpha = f(L) = \arctg\left(\frac{L}{700}\right)$$

By this corrective detachment and rotation, the spatial positioning of the goalkeeper is optimised, maximal usage of the body as a passive defensive area is ensured as well as the shortest, and at the same time the fastest way of all body parts in performing defensive movements equally to both sides, which can finally result in higher efficiency in defending penalty shots. In order to do an experimental check up of this mathematical model, we analysed the difference in efficiency in defending penalty shots between the standard and the newly suggested way in situation-related competitive circumstances. The players performed penalty shots by an arbitrary technique and tactic with the recommendation to shoot with trunk bending in accordance with the rules of the handball game. The goalkeepers defended penalty shots with the maximal step out of four metres in a way that they, by their free will or according to the shooter's reaction, were positioned in a standard way on the vertical axe at middle of the goal frame or in a newly suggested way with a corrective detachment and rotation, used again by their own free will. The results of HI-square test presented in table 1 evidently show a statistically significant (almost a double) number of defended penalty shots, but also some goal frame misses by the shooters in the cases when the goalkeepers used move and corrective rotation, than when defending penalty shots in a usual way, with no move or rotation. It is evident the goalkeepers were more than doubly efficient (32%) when defending penalty shots in the innovative way than when doing it in the usual way (15%). Further on, when the goalkeepers were positioned in an innovative way, the players were significantly

more imprecise since they missed the goal frame in 32%, and when positioned classically, there were only 11% of missed shots. It may be assumed the obtained and slightly unexpectedly large differences on behalf of the newly suggested model of positioning are the consequence of the surprise factor since the shooters probably faced for the first time this kind of an unusual and unknown way of goalkeeper's positioning. This probably contributed to a large number of shots directed outside the goal frame. In any case, it is logical to assume that one part of these differences is the consequence of spatially more favourable goalkeeper's positioning which is defined by the suggested model. By this kind of positioning, undoubtedly, a goalkeeper ensures the most favourable biomechanical and kinematical assumptions for an efficient defence, while to the shooter, they are least favourable.

Figure 1. Goalkeeper's positioning activity

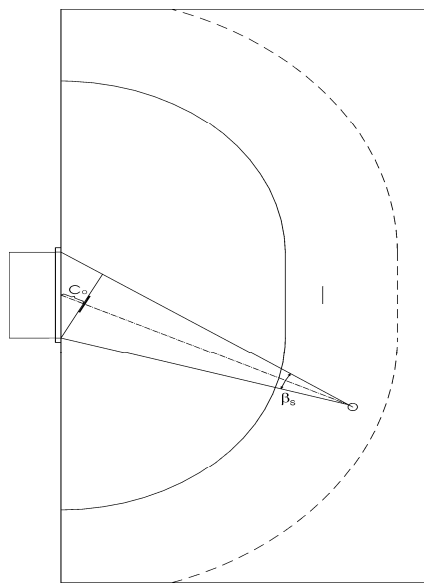
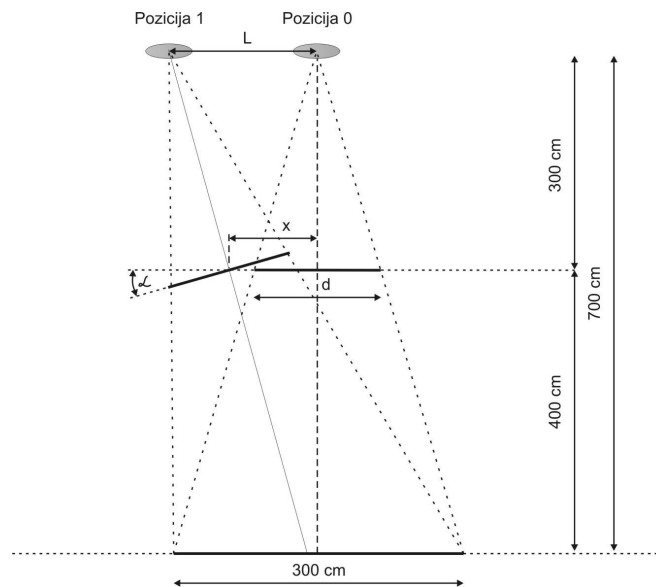

Figure 2. Suggestion for better goalkeeper's positioning



CONCLUSION

Defending penalty shots is one of the important factors influencing the final result of the match. Due to a relatively small distance from the shooter and the great ball velocity, when defending a penalty shot, a goalkeeper must primarily rely on precise positioning and setting. His basic aim is to take the most favourable, and to the shooter, the least favourable position, with regard to the characteristics of the shot. This article thus suggests experimentally checked that kind of positioning. The efficiency of the suggested model should additionally be checked by further experiments on a larger sample of penalty shots, and, by all means, empirically as well, by applying this way of defending penalty shots in situation-related competitive circumstances in matches. The results of this research may have a purposeful practical application in the method of the tactical preparation of goalkeeper at the training and a match and may immediately contribute to the efficiency in defending penalty shots.

nenad.rogulj@kifst.hr

DIFFERENCES IN CERTAIN TYPICAL PERFORMANCE INDICATORS AT FIVE CONSECUTIVE MEN'S EUROPEAN HANDBALL CHAMPIONSHIPS HELD IN 2002, 2004, 2006, 2008 AND 2010

Marko ŠIBILA, Marta BON, Mohorič UROŠ, Primož PORI

University of Ljubljana, Faculty of Sport, Ljubljana, Slovenia

Summary

Most interesting playing performance indicators were selected from five consecutive Men's European Championships held in the period from y. 2002 to 2010. We calculated descriptive statistics and differences among ECh. From obtained results we may conclude that there are many statistically significant differences in the performance indicators among the present ECh. That reveal some developing trends in contemporary Handball.

Keywords: handball, European championships, playing performance.

Introduction

Based on a system idea, sport performance is described as an issue of the "athlete system". In addition, playing performance in team handball is a special kind of player behaviour derived from the specific conditions found in a competitive match. We understand playing performance as the sum of a realised action of a player or group of players in the course of a match, which is characterised by the degree of the game task being fulfilled. We distinguish between individual and team playing performances (Taborsky, 2001). The most important conclusion from previous research dealing with a similar problem is that performance and success in contact team sports depend on many different factors, and that situation efficacy models differ for every team and almost every match (Gruić, 2006). In top senior competitions, on average teams act 60-70 times in attack and 60-70 times in defence. The average number of goals per match is on the increase. In matches played by the top eight teams at the ECh 1994 the total average number of goals per match was 47.5, whereas at the ECh 2006 it had already reached 60.5. On the other hand, in matches played by top teams the difference between the winners and losers in terms of the number of goals scored is decreasing – at the ECh 2004 it was 15.9% (4.1 goals), while at the ECh 2006 it was only 9.7% (3.1 goals) (Taborsky, 2007). In attack double pivot plays and wing crossings were used very frequently instead of a static game (Sevim, & Taborsky, 2004). Mostly at ECh 2004 attacks did not take more than 25-30 seconds. In defense the most frequently used defense system was 6:0 executed in an aggressive and cooperative style. Beside this 5:1 and 3:2:1 zone defense were applied. Other, unconventional zone systems were used very seldom during EChs. One of such exception is 4:2 zone defense applied by Czech national team (Sevim, & Taborsky, 2004). In our contribution we wish to identify the developing trends in certain playing performance indicators in handball. For this purpose we selected data from three consecutive Men's European Championships held in 2002, 2004, 2006, 2008 and 2010.

Methods

The sample of units comprised 237 matches (ECh 2002 – 50 matches, ECh 2004 – 47 matches, ECh 2006 – 47 matches, ECh 2008 – 46 matches, ECh 2010 – 47 matches). Data were gathered by official monitoring and recording during matches at the Championships with the EHF/Swiss Timing Handball EURO Scouting Manual software package. We only selected the most interesting parameters. The SPSS statistical package was used for statistical data analyses.

Descriptive statistics for the variables were computed with its fundamental measures of central tendency, dispersive parameters and homogeneity. Shapiro - Wilk test was used to verify normality of distribution. The differences in the performance indicators among all competitions were established by Kruskal-Wallis test which is nonparametric alternative for one-way ANOVA. To determine the differences between the individual championships, we have applied a series of post-hoc Mann-Whitney tests.

Results

Table 1 presents the basic statistical characteristics of the selected playing performance parameters. The table shows the average values, standard deviations, minimum and maximum values and significance of Shapiro - Wilk test for variables distribution normality.

Table 1: Basic statistical characteristics of all parameters

Parameter	Championship	\bar{x}	s	min	max	Shapiro-Wilk test Sig.
Num. of attacks	ECh 2002	53,73	4,74	41	65	,001
	ECh 2004	58,78	5,78	47	81	
	ECh 2006	58,56	4,22	49	68	
	ECh 2008	58,07	5,03	46	71	
	ECh 2010	56,82	5,9	44	69	
Num. of goals	ECh 2002	26,11	4,77	15	36	,008
	ECh 2004	28,50	4,54	20	41	
	ECh 2006	29,62	4,32	20	39	
	ECh 2008	28,08	4,58	19	41	
	ECh 2010	28,62	4,78	20	40	
Num. of goals in positional attack	ECh 2002	21,87	4,46	11	31	,028
	ECh 2004	24,31	4,12	15	35	
	ECh 2006	25,11	4,19	16	36	
	ECh 2008	23,26	4,26	15	33	
	ECh 2010	24,79	4,17	13	34	
Num. of goals in counter attack	ECh 2002	4,24	2,67	0	13	,000
	ECh 2004	4,22	2,60	0	17	
	ECh 2006	4,51	2,63	0	12	
	ECh 2008	4,82	2,52	0	13	
	ECh 2010	3,64	2,39	0	13	
Assistances	ECh 2002	15,92	6,1	2	30	,000
	ECh 2004	13,91	6,15	4	36	
	ECh 2006	12,97	4,5	2	24	
	ECh 2008	13,89	6,13	2	32	
	ECh 2010	10,96	4,5	2	23	
Steal balls	ECh 2002	4,2		0	13	,000
	ECh 2004	4,87	3,27	0	16	
	ECh 2006	4,19	2,46	0	10	
	ECh 2008	4,07	2,32	0	11	
	ECh 2010	3,12	2,08	0	11	

Blocked shots	ECh 2002	3,81	2,63	0	12	,000
	ECh 2004	3,73	2,84	0	18	
	ECh 2006	3,06	2,04	0	9	
	ECh 2008	3,28	2,42	0	15	
	ECh 2010	3,29	2,56	0	13	
Yellow card	ECh 2002	2,78	,48	1	4	,000
	ECh 2004	2,9	,3	2	3	
	ECh 2006	3,12	,64	2	4	
	ECh 2008	2,96	,51	2	4	
	ECh 2010	3,05	,52	2	4	
2min. suspension	ECh 2002	4,66	1,9	0	10	,000
	ECh 2004	5,19	1,92	1	11	
	ECh 2006	4,84	2,08	1	11	
	ECh 2008	4,29	1,91	1	10	
	ECh 2010	4,45	1,93	0	11	
Goalkeeper saves	ECh 2002	13,58	4,14	4	26	,000
	ECh 2004	13,77	3,68	3	21	
	ECh 2006	14,0	3,92	5	25	
	ECh 2008	13,77	3,63	4	29	
	ECh 2010	13,9	4,06	6	24	

\bar{x} - average values, s - standard deviations, min – minimum values, max - maximum values

The following tables show the results of Kruskal-Wallis and Mann-Whitney test based on which we established whether there were any statistically significant differences in the selected playing performance parameters among the five consecutive EChs.

Table 2: Differences in some attack parameters among the five different EChs

Parameter	Num. of attacks ^a	Num. of goals ^b	Goals in positional attack ^c	Goals in counter attack ^d	Assistances ^e
ECh 2002	53,73*	26.11*	21.87*	4.24	15.92*
ECh 2004	58,78*	28.50*	24.31*	4.22	13.91*
ECh 2006	58,56*	29.62*	25.11*	4.51*	12.97*
ECh 2008	58,07*	28,08*	23,26*	4,82*	13,89*
ECh 2010	56,82*	28,62*	24,79*	3,64*	10,96*

“*” Differences significant at $p < 0.05$.

^a2002<2004, 2006, 2008 and 2010; 2010<2004 and 2006.

^b2002<2004, 2006, 2008 and 2010; 2006>2002, 2004 and 2008.

^c2002<2004, 2006, 2008 and 2010; 2008<2006 and 2010.

^d2010<2006 and 2008.

^e2010<2002, 2004, 2006 and 2008; 2002>2004, 2006 and 2008.

In offensive parameters differences have arisen between championships in all analyzed parameters. At the ECh 2002 were played significantly fewer attacks than in other championships. It is interesting also that there were significantly fewer attacks played at the ECh 2010 than at the EChs 2006 and 2008. The surprising result in goals scored since the 2002 championship was achieved significantly fewer hits than the other championships. Most results were obtained at the European Championship 2006 and significantly more than at the EChs

2002, 2004 and 2008. Even number of goals scored in the positional attacks are characterized by significant differences between the ECh 2002 and other championships. But it was at the European Championship 2008 in this way achieved significantly fewer hits than on the EChs 2006 and 2010. At the European Championship 2010 was scored significantly fewer goals in the counterattack than at the EChs 2006 and 2008. At the ECh 2010 was recorded significantly fewer assists than at all other championships. Concerning this parameter it's interesting that at the 2002 ECh was executed significantly more assists than at all other championships.

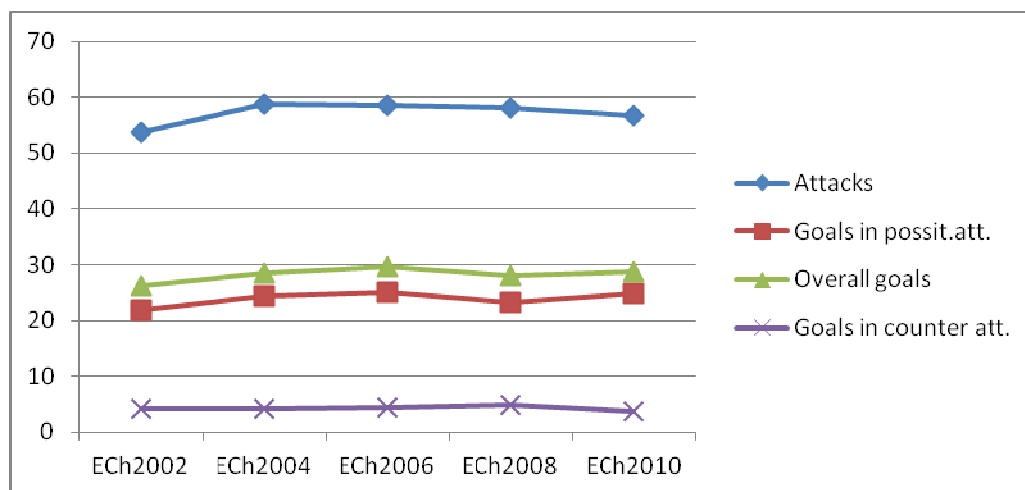

Figure 1: Numbers of attacks, overall goals, goals in positional attacks and goals from counter attack on different ECh's

Table 3: Differences in certain defence and disciplinary parameters among the five different EChs

Parameter	Steal balls ^a	Blocked shots ^b	Goalkeeper saves ^c	Yellow card ^d	2 min. suspension ^e
ECh 2002	4.20*	3.81	13.58	2.78*	4.66
ECh 2004	4.87*	3.73	13.77	2.90*	5.19*
ECh 2006	4.19*	3.06	14.00	3.12*	4.84
ECh 2008	4.07*	3.28	13.77	2.96*	4.29*
ECh 2010	3.12*	3.29	13.9	3.05*	4.45*

“*” Differences significant at $p < 0.05$;

^a2010 < 2002, 2004, 2006 and 2008.

^b no statistically significant differences.

^c no statistically significant differences.

^d 2002 < 2004, 2006, 2008 and 2010; 2004 < 2006 and 2010.

^e 2004 > 2008 and 2010.

From Table 3 we can see that the defenders on the ECh 2010 had significantly less steal balls than on EChs 2002, 2004, 2006 and 2008. In the number of blocked shots and the number of goalkeepers saves were no significant differences among Championships. Misconduct penalty notice - yellow card - was awarded 2002 ECh significantly fewer times than on the other Championships. Number of 2-min. exclusion was statistically significant higher at ECh 2004 than at EChs 2008 and 2010.

Discussion and Conclusions

We may conclude from our study that there are many statistically significant differences in the performance indicators. The number of attacks was significantly higher at the 2004, 2006, 2008 and 2010 EChs than at the 2002 ECh. But the surprising fact is that the last played ECh 2010

followed by a significant decline in the number of attacks per game in comparison with those played 2006 and 2008. In a way we could speculate that the rising number of attacks per game in handball reached a plateau at the EChs 2004, 2006 and 2008 and is now slightly in decline. This is a consequence of the rules and team tactical considerations that inappropriately designed attacks with too many rush lead to the falls efficacy. Therefore, the teams, especially at major competitions such as the ECh, slightly prefer the more controlled game with lesser number of attacks (especially with less risky quick counter-attacks) which are tactically better prepared. This speculation is supported by the fact that the number of goals scored in positional attacks from 2010 ECh does not deviate significantly from the EChs 2006 and 2008. Therefore, it was the ECh 2010 where significant less goals were scored in a counterattack than on the other discussed championships (even significantly less than at EChs 2002 and 2004). Of those parameters which describe playing quality in defence, only “Blocked shoots” and “Goalkeepers saves” appears not to be statistically significant. Appearance of this two parameters were stable through all five championships discussed. This means that changes in the rules of the game and changes in the tactics and techniques even in a relatively long period of 8 years did not cause changes in this area. So we can conclude that the efficiency of saving reached its peak some years ago. We may also speculate that improvements in the skills of shooters and goalkeepers developed simultaneously. Shooters are trying to find new ways of shooting and especially in the last few years they have being shooting more freely. As a consequence, goalkeepers seek to adapt their strategies to this kind of shooters. Therefore, we can conclude that the analysis of the statistical data does not really corroborate the findings of the qualitative analysis of goalkeepers’ performances at the ECh 2006 (Pollany, 2006). The author describes the goalkeepers’ performance as outstanding, pointing out in particular the goalkeepers’ progress in 1-on-1 actions against free shots. Something similar applies to the findings of a study where the authors compared statistical data on goalkeepers’ performances acquired at three consecutive large handball competitions – ECh 2004, OG 2004 and WCh 2005 (Sevim, & Bilge, 2007). Based on this comparison, the authors claimed that the goalkeepers’ performances improved gradually. However, it should be considered that the national teams participating at the EChs are generally more equal in terms of their quality (European teams are higher in quality than those from other continents) compared to those participating at the WCh or even the OG. Considering the above, comparisons of such data and the conclusions based thereon could be misleading. It is only reasonable to compare data acquired at competitions of an equivalent or a similar level of quality. In the future, it would be reasonable to analyse differences in statistical data regarding the performance of goalkeepers playing for winning teams and those playing for losing teams. Some effort has already been made in this direction (Rogulj, 2000; Gruić, 2006).

The results show that the average match at the ECh has become faster, with more attacks – with above described exception of ECh 2010. Consequently, more goals are being scored. The attack preparation time has shortened and the game is becoming more individualised, with fewer assistances. It is interesting that the number of goals scored from the classical counter attack is not rising. Despite a general increase in the speed of the game, the number of attacks and goals scored, it seems that teams prefer more controlled types of attacks against a zone or combined defence. These attacks have a very short preparatory phase and players decide relatively quickly to take a shot. It may be concluded that this is due to the change in the rules of the game which have led to a decrease in the duration of an attack in recent years. Here we mainly refer to Rule 7 governing the playing of the ball and passive play in attack as well as Rule 10 governing the throw off. In large competitions, the throw off after a received goal is usually performed very quickly by most teams, allowing them to gain an opportunity for a shot within a few seconds. What is also important here is the referees' criteria for granting disciplinary penalties to defenders. The referee’s task is to detect gross violations committed by defenders so as to

prevent in an unsportsmanlike manner those in offence from shooting during play. Elite players must have an excellent command of the basic and specific activities required when attacking a set defence. They must execute them quickly, in a continual manner and without any attack preparation. The practical applications stemming from our findings are as follows:

- the training and playing of short continual attacks with rapidly taken shots by different group combinations have been gaining ground;
- after an attack has been completed, it is very important to quickly return to the set defence around the goalkeeper's area;
- few or no player substitutions during the attack-defence phases, which aggravates the position of those players only specialising in attack or defence.

Marko.Sibila@fsp.uni-lj.si

MONITORING SPORT PERFORMANCE IN HANDBALL

Antanas SKARBALIUS

Laboratory of Sport Performance Monitoring, Lithuanian Academy of Physical Education, Kaunas, Lithuania

SUMMARY

The aim of this study is to give key indicators of the model of monitoring sport performance in handball. Tendency of body size, age, sporting experience and sport performance in elite men's handball, sport contest model are considered as the selected key indicators and might be used as a tool for targeting training handball players.

Keywords: elite handball, sport contest model, model of monitoring.

INTRODUCTION

There is a widening gap between scientific knowledge and practice. Permanent monitoring of sport performance and training process is the only one way to bridge the gap between sports science to practice (Bishop, 2008).

Objective data are required on changes in performance over time in order to use the information to provide individual profiles of athlete's or sports team respective strengths and weaknesses (Williams *et al.*, 2011).

Handball is a complex sport. Besides variables of sport performance the physiological and physical demands of handball require players to be competent in several aspects of fitness, which include aerobic and anaerobic power, muscle strength, flexibility and agility. Tests can be used to evaluate the impact of these interventions on the physical fitness profile of individual players, thereby evaluating the effectiveness of the programme (Swensson, Drust, 2005).

So many aspects related to handball complexity needs to use complex indicators for monitoring (Figure 1) sport performance and training aspects in handball (Skarbalius, 2010).

The aim of this study is to give sample of analysis how to use scientific research in order to find out trends of sport performance in handball. Due to the Conference requirements of limitation to the length of the article we give selected aspects only of the model of complex monitoring in handball.

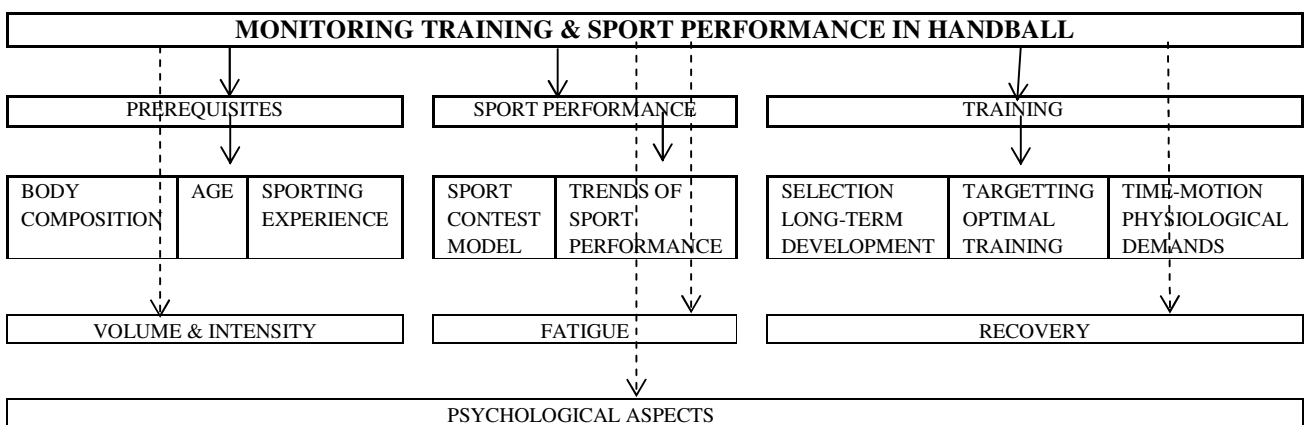

Figure 1. Model of monitoring sport performance in handball (Skarbalius, 2010)

METHODS

Data. We analyzed Olympic and European handball in order to carry out the prerequisites to sport performance and the trends of sport performance in elite men's handball. The data sets gathered from the International Handball Federation (IHF) website (www.ihf.com) cover Olympic handball (OH) in 10th (1972–2008) Olympic Games (OG) men's tournaments, and from the European Handball Federation (EHF) website (<http://eurohandball.com>) cover the five European Men's Handball Championships (EC) held in 2002–2010 (Table I). Ethics approval was not required as the data sets are publically available.

Table I. Number of players, matches of the men's Olympic Games (OG) and European Championships (EC)

OG	1972	1976	1980	1984	1988	1992	1996	2000	2004	2008	Total
Players	256	152	168	168	211	195	191	180	168	180	1869
Matches	44	30	36	36	36	38	38	42	44	42	386
EC	2002		2004		2006		2008		2010		Total
Players	256		254		273		249		259		1291
Matches	50		48		47		47		47		239

Statistical analysis. A discriminant analysis was employed to identify a subset of game-related statistics that discriminated between winning and losing teams in each of the five EMHC. In the final discriminant model were included the variables with significant inequality of group means (the Wilks' lambda statistic) and with highest absolute values of the correlation coefficient between discriminating variables and standardised canonical discriminant functions using a general linear model analysis of variance (ANOVA), with Tukey Post Hoc test using PASW 18.0 statistical package. The ANOVA was evaluated as significant when there was a < 5% chance of making a type I error ($P < 0.05$). Significance for all statistical tests was set at the $P < .05$ level.

RESULTS

Prerequisites of height, body mass, age, sporting experience to sport performance in elite men's handball. Handball players (Table 2) during 36 years – from Munich to Beijing Olympic Games (OG) – were 6.3 cm higher ($p < 0.001$), heavier in 10.1 kg ($p < 0.001$), 2.6 years more mature in age ($p < 0.001$) and had played 48 international matches more ($p < 0.001$). Changes of mentioned variables in European men's handball through last decade (2002–2010) were small or trivial (body mass) according Hopkin's scale (2002).

Table II. Body composition (height, body mass) age, sporting experience (international matches played) in elite men's handball (mean \pm s)

Variable	OLYMPIC GAMES		Magnitude of change (ES)	EUROPEAN CHAMPIONSHIPS		
	1972	2008		2002	2010	Magnitude of change (ES)
Height, cm	184.5 \pm 5.0	191.1 \pm 6.5 [#]	Large	190.9 \pm 2.5	191.8 \pm 6.7	Small
Body mass, kg	82.3 \pm 5.6	92.4 \pm 8.6 [#]	Large	92.6 \pm 2.4	92.9 \pm 9.3	Trivial
Age, years	25.9 \pm 3.3	28.5 \pm 4.1 [#]	Moderate	28.4 \pm 0.8	27.7 \pm 3.9*	Small
International matches	45.5 \pm 31.2	93.4 \pm 9.7 [#]	Very large	92.5 \pm 26.4	83.2 \pm 63.9	Small

Note: # Significant at $P < 0.001$ within Olympic Games. * Significant at $P < 0.05$ within European Championships. ES Subjective representation of standard effect size comparisons within OG and within EC was performed using the following scale: trivial <0.2, small; 0.2–0.6, moderate 0.6–1.2, large 1.2–2.0, and very large >2.0 (Hopkins, 2002).

Sport performance in Olympics. During 36 years (Table III) teams scored 11 goals more ($p < 0.001$) (1972 – 16.3 ± 1.9 ; 2008 – 27.3 ± 4.3) per match, both teams scored 22.3 ($p < 0.001$) goals more (32.3 ± 7.2 , and 54.6 ± 6.9 respectively). Winners scored 19.6 ± 3.7 goals in 1972, and 9.5 goals more ($p < 0.001$) in 2008 (29.1 ± 3.9). Goals scored by losers increased ($p < 0.001$) by 10.5

Table III. Sport performance in Olympic men's handball (mean \pm s)

Variable	1972 Münich	2008 Beijing	Magnitude of change	
			Effect size	Hopkin's scale
Goals scored by one team	16.3 ± 1.9	$27.3 \pm 4.3^{***}$	3.54	Very large
Goals scored by both teams	32.3 ± 7.2	$54.6 \pm 6.9^{***}$	3.16	Very large
Goals scored by winners	19.6 ± 3.7	$29.1 \pm 3.9^{***}$	2.50	Very large
Goals scored by losers	13.9 ± 1.8	$24.4 \pm 4.3^{***}$	3.44	Very large
Number of attacks	38.8 ± 5.9	$56.0 \pm 4.4^{***}$	3.33	Very large
Efficacy of attacks, %	43.1 ± 6.7	$48.7 \pm 7.4^{**}$	0.79	Trivial
Ratio of positional attacks, %	91.4 ± 5.7	$86.6 \pm 6.9^{**}$	0.76	Trivial
Efficacy of positional attacks, %	41.7 ± 6.5	$45.6 \pm 8.0^*$	0.53	Trivial
Ratio of counter-attacks, %	8.6 ± 2.9	$13.4 \pm 6.9^{***}$	0.97	Trivial
Efficacy of counter-attacks, %	49.8 ± 11.2	$69.0 \pm 18.9^{***}$	1.27	Large
Shots efficacy, %	40.3 ± 5.3	$55.3 \pm 9.0^{***}$	2.09	Very large
Goalkeepers saved shots, %	43.8 ± 6.9	$30.8 \pm 10.0^{***}$	1.53	Large
Shots blocks (since 1976 Montreal OG)	1.7 ± 0.9	$3.5 \pm 2.5^{***}$	1.05	Moderate
Steals (since 1992 Barcelona OG)	1.7 ± 0.6	$4.0 \pm 2.5^{***}$	1.48	Moderate
Mistakes (since 1976 Montreal OG)	12.9 ± 3.6	13.0 ± 4.2	0.02	Trivial
Suspension 2 minutes	3.3 ± 1.6	$7.1 \pm 3.2^{***}$	1.58	Large

Note: * Significant at $P < 0.05$, ** $P < 0.01$, *** $P < 0.001$.

goals (13.9 ± 1.8 , and 24.4 ± 4.3 respectively). Number of attacks increased ($p < 0.001$) by 16.6 attacks (39.4 ± 6.2 , and 56.0 ± 4.4 respectively), efficacy of attacks increased ($p < 0.001$) by 14.1% (34.6 ± 6.3 , and 48.7 ± 7.4). Shots efficacy increased ($p < 0.001$) by 15% (40.3 ± 5.3 , and 55.3 ± 9 respectively), but goalkeepers efficiency decreased ($p < 0.001$) by 8.5% (43.8 ± 6.9 , and 30.0 ± 8.0 respectively). The difference between scored and missed goals through fourth decades decreased by 1 goal. The phenomenon of modern olympic male handball is that winners play more vigorous and aggressive, and make more violations (2 minutes suspension increased [$p < 0.001$] in double: from 3.3 ± 1.6 to 7.1 ± 3.2).

Sport performance of European men's modern handball. Discriminant analysis (Table IV) between winners and losers in the last decade. The phenomenon of EC'2002–2010 is that winners exceed ($P < 0.01$, $P < 0.001$) losers throughout all the championships in efficacy of positional attacks, but moderate value of efficacy of positional attacks of European handball and the last three at the OH is the same (44–46%). Winning and losing teams in the EC'2002–2010 played in the same pattern ($P > 0.05$) because the ratio of positional attacks as well as counterattacks varied slightly. The ratio of positional attacks for winners varied between 84.5–90.9% from total attacks, and between 86.4–90.4% for losing teams. No significant difference of efficacy of team counterattacks were found in the EC'2002–2010 between winners and losers: i. e. varied between 63–75% for winners and 59–66% for losers. The phenomenon is that winners performed losers better ($P < 0.05$) at the EC'2010 in minority. Winners did not exceed losers in none of the indices of positive and negative indices throughout EC'2002–2010, but they outperformed losers ($P < 0.05$, $P < 0.01$, $P < 0.001$) in blocked shots (moderate 3.1–4.1 blocks) at the fourth EC'2002–2008. The winners at EC'2002–2010 exceed ($P < 0.001$) the losers in total shooting performance and long distance ($P < 0.01$, $P < 0.001$) indicators. Throughout EC'2002–2010 teams on average earned a 7 m penalty 4.3–4.8 times per match, performed steals 3.1–5.1 times and made 11.2–12.5 mistakes.

Table IV. Sport performance in European Championships (2002–2010) men's handball (mean ± s)

Variable	2002			2010			Magnitude of change (ES)	
	Winners	Losers	Magnitude of change (ES)	Winners	Losers	Magnitude of change (ES)	Winners 2002–2010	Losers 2002–2010
Goals scored	27.9 ± 4.5	23.4 ± 3.9**	Moderate	30.2 ± 4.7	26.6 ± 4.3***	Very large	Small	Small
Goals missed	23.5 ± 3.8	29.1 ± 3.8***	Moderate	27.2 ± 4.3	30.3 ± 4.8***	Moderate	Moderate	Small
Efficacy of attacks, %	52.1 ± 6.2	43.3 ± 5.9***	Moderate	53.5 ± 6.2	46.5 ± 5.5***	Moderate	Small	Small
Ratio of positional attacks, %	85.8 ± 6.3	89.5 ± 5.2	Moderate	90.9 ± 4.8	91.3	Trivial	Moderate	Small
Efficacy of positional attacks, %	49.9 ± 7.3	42.5 ± 10.1***	Moderate	51.2 ± 6.4	44.5 ± 5.7***	Moderate	Trivial	Small
Ratio of counter-attacks, %	14.2 ± 6.3	10.3 ± 5.3	Moderate	9.1 ± 4.9	8.42 ± 4.6	Trivial	Moderate	Small
Efficacy of counter-attacks, %	62.3 ± 24.3	58.9 ± 28.9	Trivial	74.6 ± 23.9	64.1 ± 27.5	Small	Small	Trivial
Efficacy of individual counter-attacks, %	84.4 ± 31.3	72.8 ± 41.1	Small	43.6 ± 45.9	32.1 ± 44.4**	Small	Moderate	Moderate
Efficacy of team counter-attacks, %	55.4 ± 26.4	55.4 ± 30.9	Trivial	65.0 ± 58.1	63.5 ± 27.7	Trivial	Small	Small
Majority, %	61.9 ± 18.5	54.9 ± 22.4	Small	63.2 ± 17.7	54.5 ± 23.5*	Small	Trivial	Trivial
Minority, %	43.6 ± 22.5	34.1 ± 25.8	Small	47.4 ± 26.2	38.1 ± 25.6	Small	Trivial	Trivial
Shots efficacy (total), %	57.3 ± 7.5	48.1 ± 6.9***	Small	59.2 ± 7.2	53.4 ± 6.9*	Moderate	Small	Moderate
Shots efficacy (7 m), %	66.9 ± 25.9	65.2 ± 31.7	Trivial	69.7 ± 25.1	72.5 ± 26.4	Trivial	Trivial	Trivial
Shots efficacy (6 m), %	66.7 ± 18.6	59.3 ± 23.2	Trivial	75.8 ± 16.4	75.1 ± 17.6	Trivial	Small	Moderate
Shots efficacy (wings), %	55.6 ± 22.5	53.3 ± 28.4	Trivial	59.9 ± 21.5	55.6 ± 21.8	Trivial	Trivial	Trivial
Shots efficacy (counter-attacks), %	74.6 ± 21.7	71.9 ± 27.4	Trivial	74.4 ± 25.7	70.9 ± 29.8	Trivial	Trivial	Trivial
Shots efficacy (long distance), %	42.7 ± 11.9	33.4 ± 10.4***	Moderate	43.9 ± 11.5	37.8 ± 11.1**	Moderate	Trivial	Small
Goalkeeper's safes shots (total), %	37.1 ± 7.6	29.9 ± 6.7*	Moderate	34.4 ± 8.5	30.2 ± 6.9**	Moderate	Small	Trivial
Goalkeeper's safes shots (7 m), %	23.7 ± 28.9	30.7 ± 26.7	Small	24.3 ± 14.9	22.1 ± 22.3	Trivial	Small	Small
Goalkeeper's safes shots (6 m), %	31.2 ± 23.3	29.1 ± 19.7	Trivial	20.3 ± 19.4	23.1 ± 18.1	Trivial	Small	Small
Goalkeeper's safes shots (wings), %	38.6 ± 25.6	30.3 ± 20.8	Small	33.8 ± 20.6	31.7 ± 22.2	Trivial	Small	Trivial
Goalkeeper's safes shots (counter-attacks), %	19.1 ± 19.5	18.2 ± 15.3	Trivial	24.6 ± 25.5	17.3 ± 19.3	Small	Small	Trivial
Goalkeeper's safes shots (long distance), %	49.8 ± 14.4	39.9 ± 14.4**	Moderate	46.3 ± 12.8	40.4 ± 11.9*	Small	Small	Trivial
Earned 7 m	4.5 ± 1.8	4.1 ± 2.3	Trivial	4.5 ± 2.1	4.3 ± 2.3	Trivial	Trivial	Trivial
Steals	4.7 ± 2.9	3.8 ± 2.3	Small	3.5 ± 2.1	2.6 ± 1.9	Small	Small	Small
Shot's blocks	4.7 ± 2.7	2.9 ± 1.7***	Large	3.1 ± 2.2	3.6 ± 3.1	Trivial	Moderate	Trivial
2 minutes suspension	9.5 ± 3.5	9.2 ± 3.8	Trivial	8.4 ± 3.9	9.5 ± 3.8	Small	Small	Trivial
Mistakes in offence	10.7 ± 3.9	11.8 ± 4.9	Small	10.9 ± 3.2	12.5 ± 3.9*	Small	Trivial	Trivial

Note: * Significant at $P < 0.05$, ** $P < 0.01$, *** $P < 0.001$ between winners and losers within EC'2002, and EC'2010. ES – Subjective representation of standard effect size comparisons was performed using the following scale: trivial <0.2 , small; 0.2–0.6, moderate 0.6–1.2, large 1.2–2.0, and very large >2.0 (Hopkins, 2002).

DISCUSSION

Prerequisites of body size. Despite findings of importance of body size in elite sport performance (Norton, Olds, 2001) current study did not show uniformity of prevalence of height, body mass, or experience to win a match in male Olympic handball. Correlation between winnings points and indices varied from OG to OG: height (0.238–0.791), body mass (0.271–0.657), age (0.133–0.798), international matches played (0.243–0.666). Trivial interaction were found between body size and winning points, but small interaction of sporting experience in European men's handball (Skarbalius, 2010).

Sport performance in elite men's handball. The aim of this study is to illustrate the trends of Olympic men's handball through 4 decades, and discriminant indicators of sport performance between winners and losers in European men's modern (2002–2010) handball match activities. Changes in handball match activities are defined by the number of attacks and goals scored per match (Heigerisson, 2008; Mocsai, 2002; Polany, 2006, 2010; Sevim, Taborsky, 2004; Skarbalius, 2002, 2006, 2010; Taborsky, 2008). During four decades between the years 1972–2008 Olympic handball (OH) became more dynamic (Skarbalius, 2002, 2010): number of attacks increased ($P < 0.001$) by 17.2 attacks (Beijing OG, 56 ± 4.4) and goals scored by both teams increased ($P < 0.001$) by 22.3 goals (Beijing OG, 54.6 ± 6.9), but this was still 2.1 goals less compared to the EC'2010. Empirical research investigating performance analysis in handball has been limited to studies exploring, for example, the patterns of team play. To date, there have been no performance analysis of elite men's handball, assessing team performance via the evaluation of team playing pattern indicators. The same ratio of positional attacks was found at the Beijing OG'2008 ($86.6 \pm 6.9\%$), but less as in the beginning of OH (Münich OG'1972 – $91.4 \pm 5.7\%$) (Skarbalius, 2002, 2010). Whilst changes (Pyne *et al.*, 2004) appear small in size (less than 1%), they have a substantial effect on the outcome of competition (Trewin *et al.*, 2004). *Team counterattack* is a considerable feature of modern handball (Hergerisson, 2008; Pollany, 2006, 2010; Sevim, Taborsky, 2004). *Two minutes suspension.* At OH where the teams who achieved higher placing performed more vigorous and aggressive actions, did not take risks and made more rules violations, but most frequently won the match (Skarbalius, 2002, 2010). *Goalkeepers.* Winners differed significantly throughout EC'2000–2006: i. e. saves of positional attacks and goals from long distance (Wiemeyer, Heinz, 2008), the average number of shots from 9 m and the wing position in the EC'2004, 2006; the number of goalkeeper saves (Pori *et al.*, 2008) remained at the same level (2002 – 31.6%; 2004 – 32.6%; 2006 – 32.0%). Hergerisson (2008) argued that the goalkeepers saved more shots in general and from 6 metres, and there was especially better cooperation between goalkeeper and defense at the EC'2008.

Positive and negative actions. Wiemeyer and Heinz (2008) suggested that due to the development of the game, in the EC'2006 steals became more important and this feature indicated the fast switch from defense to offense, which played a decisive role. Our research did not show that winning teams were superior at stealing the ball and the ratio of counterattacks. On the other hand, Wiemeyer and Heinz (2008) concluded that there were variables specific to one or two championships, which may be considered as 'short-term fashion' in the development of handball tactics. In contrast to our research, Taborsky (2008) pointed out that mistakes at the Beijing OG (12.9 mistakes in offence) were the key indicators of sport performance in men's handball. This allows to assert of increasing equable performance by rival teams in elite male handball. Increasing a number of attacks, efficacy of attacks, and efficacy of shots might be characterize as the dominant features of players individual skills in offense as in defense. Decreasing ratio (4.8%) of positional attacks and increasing ratio of

counterattacks as well as efficacy of latter index might be thought as increasing dynamics of the game (Skarbalius, 2002, 2010).

In summarize modern Olympic male handball is more dynamic; winners play more active and aggressive handball; prevails individual actions in offence; elite rival teams are the same performance level; complex indicators of sport performance might decide the end of a match. We suggest that playing pattern in elite male Olympic and European handball may have more influence to win than body size. Sport performance monitoring findings allow to affirm that six indicators – goals scored, efficiency of total attacks and positional attacks, efficiency of total shots, from long distance, and shots saved by goalkeepers – are the key indicators of discriminant winners in elite men’s handball. Five indicators amongst those mentioned (except saved shots by goalkeepers) are characteristic of actions in offence and playing patterns of team actions. The next three indicators (goals missed, blocked shots, saved long distance shots), characterize defensive actions and individual fitness of players as having the second level of importance in order to win. Performance indicators such as efficiency of individual attacks, shots from wings and 7 m penalties, and efficiency in minority might be considered as the key indicators of temporal pattern.

CONCLUSIONS

Despite great importance of body size to sport performance in general, height, body mass have not significant influence in elite handball. Sporting experience may have more important role in order to win in Olympics or European championships. Sport contest model in handball need-be review and might be considered to add several important indicators (efficacy of defence systems, activities in 6–9 m zone, free-throws). Changes in modern handball requires permanent assessment of time-motion and physiological demands during matches in order to design adequate training programme.

a.skarbalius@lkka.lt

PERFORMANCE AND KINEMATICS OF VARIOUS THROWING TECHNIQUES AND SKILL LEVELS IN TEAM-HANDBALL

Herbert WAGNER , Jürgen PFUSTERSCHMIED, Serge P. von DUVILLARD, Erich MÜLLER

University of Salzburg, Salzburg, Austria

Summary

In the present study we found significant differences in ball velocity but not in throwing accuracy between different throwing techniques and skill levels. To increase performance in team-handball throwing, the players had to learn two different strategies of pelvis and trunk acceleration depending on the floor contact (standing vs. jumping) and less experienced players should increase the trunk and shoulder internal rotation angular velocity.

Keywords: Throwing techniques, skill levels, performance, kinematics

Introduction

In team-handball competition, the players utilize various throwing techniques. Seventy-three to 75% of all throws during the game constitute jump throws, followed by the standing throws with run-up (14-18%), penalty throws (6-9%), diving throws (2-4%) and direct free throws (0-1%) (Wagner et al., 2008). The run-up is limited to the jump throw and standing throw with run-up. These techniques are used to increase the horizontal velocity, making it difficult for the defensive player to defend and potentially enabling a higher ball velocity. In recent studies, it was shown that performance and kinematics in the jump throw differ depending on the skill level (Wagner et al., 2010a), that a transfer of momentum from proximal to distal and dynamic trunk and shoulder joint movements increase ball velocity in team-handball throwing (van den Tillaar and Ettema, 2007, 2009; Wagner et al., 2010a) and that in different throwing techniques (throwing arm above vs. trunk side) elite team-handball players attempt to move their throwing arm similarly to increase ball velocity (Wagner et al., 2010b).

It is well known that different throwing techniques differ in the lower body movement. The standing throw involves keeping the lead foot on the floor during the throw that is typical for the penalty throw in team-handball. In the standing throw with run-up, one foot is planted on the floor after the run-up. The jump throw involves executing a vertical jump of off one leg at take-off after the run-up. In the pivot throw, the thrower performs a vertical jump from both legs at take-off after turning. These different throwing techniques are fundamental skills in elite, skilled, and low skilled team-handball players; however, a study comparing different throwing techniques and skill levels in team-handball throwing is lacking. Based on these differences it should be explored how the foot planting on the floor (stemming in the standing throw with run-up) vs. vertical jump with one or two legs at take off influence the throwing movement and, ultimately, ball velocity. As described before, the standing throw with run-up and the jump throw are the most applied throwing techniques in competition, therefore, we reduced our analyses to these two throwing techniques. Consequently, the aim of this study was to analyze differences in performance and kinematics between the team-handball jump and standing throw with run-up in players with different skill levels. Based on previous studies (van den Tillaar and Ettema, 2007, 2009; Wagner et al., 2010a, 2010b), we hypothesized to find significant differences in the ball velocity and upper body kinematics (maximal angles, angular velocities and there timings).

Methods

Twenty-four male volunteers participated in our study. All participants were physically healthy, in good physical condition and reported no injuries during the time of the study. The local Ethics Committee approved the study and informed written consent was obtained from each participant before testing. Depending on their experience in training and competition, participants were divided into three groups (n=8) of various skill levels:

- Low-skilled players (mean age: 19.5 ± 5.9 years, body weight: 71.3 ± 9.0 kg, body height: 1.75 ± 0.04 m, training experience: 1.6 ± 0.9 years).
- Skilled players from a regional handball team (mean age: 20.4 ± 5.3 years, body weight: 74.0 ± 8.6 kg, body height: 1.83 ± 0.05 m, training experience: 7.4 ± 3.8 years).
- Elite players from the Austrian National Team and Second Austrian Handball League (mean age: 24.0 ± 2.5 years, body weight: 88.0 ± 8.8 kg, body height: 1.87 ± 0.07 m, training experience: 12.6 ± 2.1 years).

After a general and a team handball specific warm up of 20 min, the participants were asked to perform 10 valid standing throws with run-up and 10 vertical jump throws with their preferred throwing arm. The order of the two throwing techniques was randomized for each participant. Between trials, players rested for ~1 min. This procedure ensured that the results were not influenced by fatigue. The instruction for each trial was to throw the ball (IHF Size 3) at a target of 8 m distance and to strike the center of a square of 1×1 m at about eye level (1.75 m) with maximal ball velocity and accuracy. The center of the square was defined as the midpoint that was clearly visible and marked with a large cross. To eliminate obvious mistakes we used only those throws (valid throws) that stroke the target. This continued until 10 valid throws for each throwing technique for each participant were accomplished and recorded.

The experimental set-up consisted of an 8 camera Vicon MX13 motion capture system (Vicon Peak, Oxford, UK), capturing at 250 Hz. For kinematic analysis, 39 reflective marker of 14 mm diameter were affixed to specific anatomical landmarks (Plug-In Gait Marker Set, Vicon Peak, Oxford, UK) for every participant (Figure 1). Three-dimensional trajectories of 39 markers were analyzed utilizing Nexus software (Nexus 1.3, Vicon, Oxford, UK) and filtered with a Woltring filter (Woltring, 1986). To calculate the joint positions, a 3D-model (Plug-In Gait Model, Vicon Peak, Oxford, UK) was used (Davis et al., 1991). The model was identical to that of Wagner et al. (2010a) who analyzed the jump throw in team-handball.

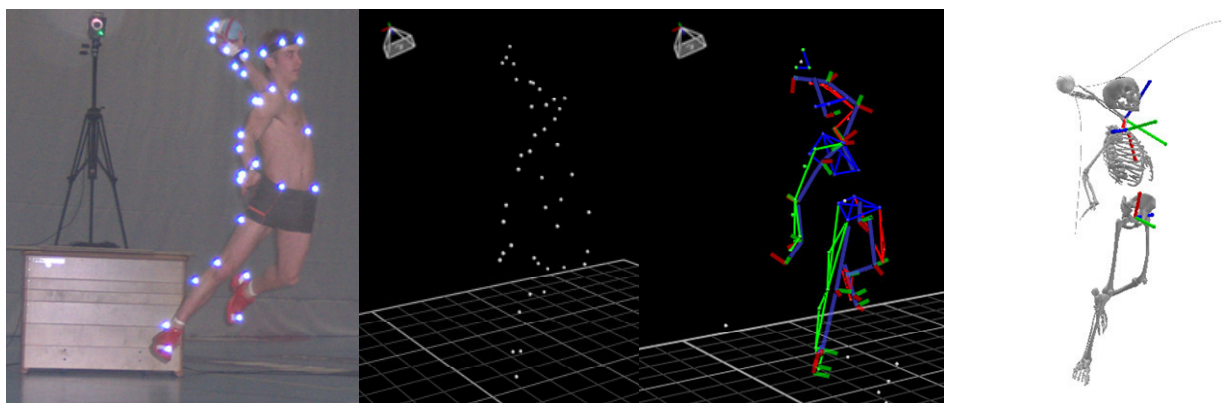

Figure 1. Participant with reflective markers (1), reconstructed trajectories in Nexus 1.3 (2), labeled trajectories with calculated joint positions and joint axes (3) and calculated bones (4).

For joint angle calculation we used the same method as described by Wagner et al. (2010a). Joint angles were calculated by the relative orientation of the proximal and distal segments.

Trunk (pelvis) rotation angles were calculated between the sagittal axis of the trunk (pelvis) and the sagittal axis of the measuring field. The shoulder internal-external rotation angle was defined as the rotation of the humerus along the longitudinal axis of the humerus. A positive value corresponds to internal shoulder rotation. The elbow flexion angle was determined by the longitudinal axes of the proximal and distal segment. Angular velocities and ball velocity were calculated using the 5-point central differential method.

To determine the ball release point, the distance between the center of the ball and the finger of the throwing arm was calculated. This distance increased abruptly at ball release (van den Tillaar & Ettema, 2007). For a detailed discussion of the results, we separated the throwing movements into three different phases, two phases before ball release (arm cocking and acceleration phase) and one after ball release (post ball release). Cocking phase was defined from the beginning (400ms before ball release) to the beginning of acceleration phase. We termed the acceleration phase as the time lag between the moment when the angular acceleration of the trunk rotation became maximal to ball release, and post ball release from ball release to the end (100ms after ball release). The total time frame was chosen from 400ms before to 100ms post ball release that was sufficient to calculate all relevant variables (van den Tillaar and Ettema, 2007; Wagner et al., 2010a,b). Throwing accuracy was determined by the percentage of the throws that missed the target relative to all throws for each participant and the mean radial error (van den Tillaar & Ettema, 2003). Mean radial error was calculated as the distance of the ball target impact point to the center of the target and was measured with Peak Motus 9.0 (Vicon Peak, Oxford, UK) using a digital video camera, operating at 120 Hz.

Statistical analysis was conducted via SPSS ver. 16.0 (SPSS Inc., Chicago, IL, USA) software. Means and standard deviations (SD) of the variables were calculated for descriptive statistics. A two-way MANOVA with the main factors throwing technique and skill level was used to calculate the differences in performance and kinematics (pelvis, trunk, shoulder rotation and elbow extension/flexion). To determine significant differences between single variables we used the Bonferroni post-hoc test.

Results

Two-way MANOVA yielded significant effects for the factor throwing technique ($P < 0.001$) and skill level ($P < 0.001$). In performance, we found significant differences between throwing techniques ($P < 0.01$) and skill levels ($P < 0.001$) solely in the ball velocity (Figure 2).

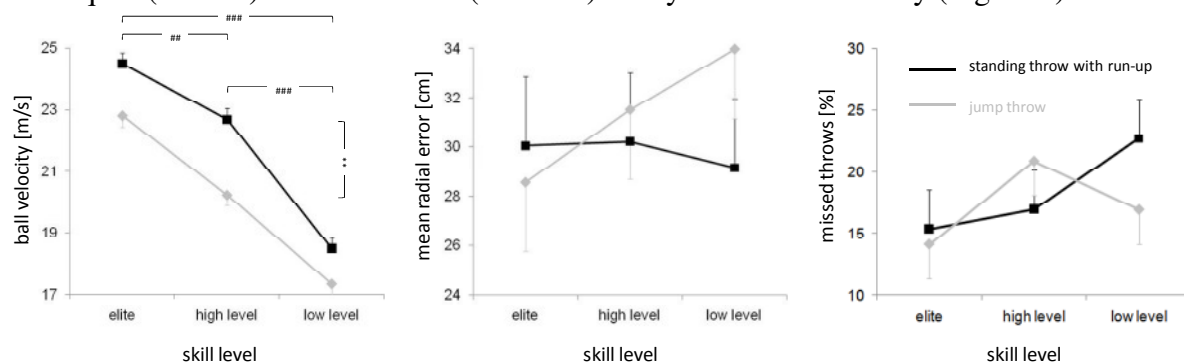

Figure 2. Interaction between skill level \times throwing technique in ball velocity (1), mean radial error (2) and percentage of missed throws (3).

In the kinematic variables, two-way MANOVA yielded significant effects for the factor throwing techniques (n=5), skill levels (n=11) and the interaction of throwing technique × skill level (n=2) as depicted in table 1.

Table 1. Mean (\pm SD) maximal angular velocities, angles and their timing (pelvis, trunk, shoulder internal/external rotation, elbow extension/flexion) differentiated in throwing techniques and skill levels and the effects calculated by the two-way MANOVA.

	Standing throw with run-up			Jump throw			Main effect
	Elite	Experienced	Low experienced	Elite	Experienced	Low experienced	
<i>Maximal angular velocity (°/s)</i>							
Pelvis rotation	640 \pm 100	550 \pm 80	560 \pm 120	470 \pm 100	400 \pm 110	420 \pm 120	***
Trunk rotation	860 \pm 80	780 \pm 70	780 \pm 150	770 \pm 50	650 \pm 100	690 \pm 140	**,#
Shoulder int. rotation	6120 \pm 1220	5160 \pm 1040	4660 \pm 1120	5400 \pm 870	4550 \pm 900	4860 \pm 1000	#
Elbow extension	1740 \pm 320	1590 \pm 240	1380 \pm 430	1720 \pm 180	1520 \pm 200	1350 \pm 370	##
<i>Timing maximal angular velocity (s)</i>							
Pelvis rotation	-0.11 \pm 0.03	-0.11 \pm 0.02	-0.11 \pm 0.02	-0.11 \pm 0.02	-0.13 \pm 0.03	-0.13 \pm 0.06	
Trunk rotation	-0.08 \pm 0.02	-0.09 \pm 0.02	-0.10 \pm 0.02	-0.08 \pm 0.01	-0.11 \pm 0.03	-0.10 \pm 0.03	#
Shoulder int. rotation	0.00 \pm 0.01	0.01 \pm 0.01	0.01 \pm 0.01	0.00 \pm 0.01	0.00 \pm 0.01	0.00 \pm 0.01	##
Elbow extension	-0.02 \pm 0.01	-0.01 \pm 0.01	-0.01 \pm 0.01	-0.17 \pm 0.09	-0.24 \pm 0.10	-0.12 \pm 0.07	###
<i>Maximal angle (°)</i>							
Pelvis rotation	-81 \pm 10	-58 \pm 29	-21 \pm 25	-43 \pm 8	-30 \pm 18	-31 \pm 8	**,###,ii
Trunk rotation	-93 \pm 8	-84 \pm 10	-89 \pm 7	-66 \pm 9	-61 \pm 7	-64 \pm 10	###
Shoulder ext. rotation	150 \pm 9	147 \pm 11	145 \pm 16	147 \pm 9	145 \pm 14	134 \pm 15	
Elbow flexion	91 \pm 14	95 \pm 15	102 \pm 15	97 \pm 16	108 \pm 11	98 \pm 11	
<i>Timing maximal angle (s)</i>							
Pelvis rotation	-0.32 \pm 0.02	-0.24 \pm 0.11	-0.04 \pm 0.11	-0.30 \pm 0.04	-0.25 \pm 0.11	-0.23 \pm 0.08	*,###,ii
Trunk rotation	-0.29 \pm 0.02	-0.26 \pm 0.03	-0.28 \pm 0.05	-0.25 \pm 0.02	-0.25 \pm 0.02	-0.24 \pm 0.04	##
Shoulder ext. rotation	-0.03 \pm 0.01	-0.03 \pm 0.01	-0.04 \pm 0.02	-0.04 \pm 0.02	-0.05 \pm 0.02	-0.04 \pm 0.03	
Elbow flexion	-0.13 \pm 0.08	-0.17 \pm 0.10	-0.09 \pm 0.03	-0.17 \pm 0.09	-0.24 \pm 0.10	-0.12 \pm 0.07	*,###

Significant effect for the factor throwing technique (*: $P < .05$; **: $P < .01$; ***: $P < .001$); Significant effect for the factor skill level (#: $P < .05$; ##: $P < .01$; ###: $P < .001$); Interaction throwing technique × skill level (i: $P < .05$; ii: $P < .01$; iii: $P < .001$)

Discussion

We found significant differences in the ball velocity between the throwing techniques as well as the skill levels. Team-handball players were able to throw the ball faster in the standing throw with run-up compared to the jump throw and ball velocity increased with the level of performance. In the throwing accuracy (mean radial error and percentage of missed throws) we found no significant differences between the skill levels and throwing techniques. In the standing throw with run-up and jump throw elite, experienced and low experienced players were able to strike the target accurately and frequently (no speed-accuracy trade-off). In different skill levels and throwing techniques players were able to throw just as accurately when the ball velocity significantly increased. These results are in agreement with previous studies in team-handball (Bayios & Boudolus, 1998; van den Tillaar & Ettema, 2003, 2006; Wagner et al., 2010a).

In team-handball throwing van den Tillaar and Ettema (2009) and Wagner et al. (2011) found that ball velocity contribute significantly to a proximal-to-distal sequence. As shown in table 1 maximal angular velocities occurred in a proximal-to-distal order in both throwing techniques and all skill levels, beginning with the pelvis rotation, followed by the trunk rotation and shoulder internal rotation. We observed that all players in the present study were able to throw the ball with the right technique (in a proximal-to-distal order) to enable a transfer of momentum through the pelvis and trunk to the throwing arm. The increased ball velocity in the elite compared to the experienced and low experienced players could be explained by the higher maximal angular velocities in the trunk rotation, shoulder internal rotation and elbow extension. Elite players were able to rotate the trunk and shoulder, and to extend the elbow faster that lead to higher ball velocities (van den Tillaar and Ettema, 2007; Wagner et al., 2010a).

The increased ball velocity in the standing throw with run-up could be explained by a better transfer of momentum from proximal to distal. The lead leg braces the body that allows the pelvis, trunk, and throwing arm to accelerate over the braced leg. As shown in figure 3 in the standing throw with run-up (black line), the pelvis and trunk was more rotated in the cocking phase that enables a longer acceleration (over the braced leg) and resulted in a higher angular velocity in the acceleration phase. In the jump throw, the missing floor contact of the lead leg demands a different strategy to accelerate the pelvis and trunk (fewer pelvis and trunk rotations in the cocking phase lead to a fewer angular velocities in the acceleration phase) that lead to a decrease in ball velocity. However, elite and highly skilled players were able to increase angular velocity in the pelvis, trunk and shoulder rotation in both throwing techniques that lead to higher ball velocity in comparison to the low skilled players.

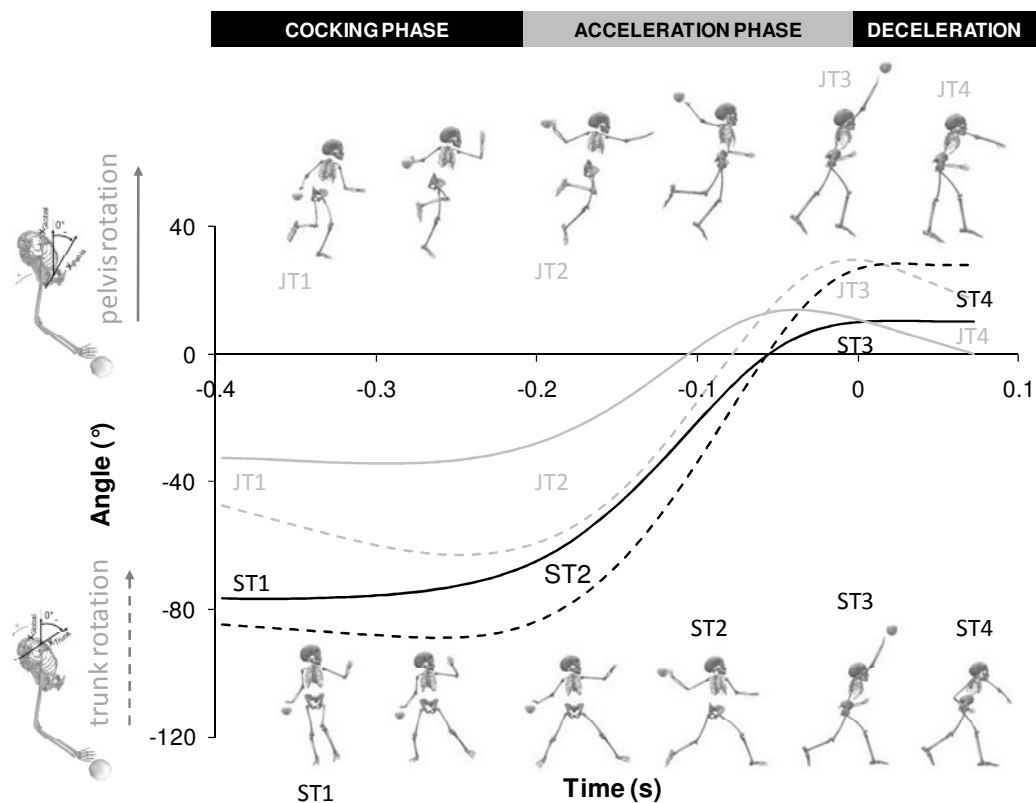

Figure 3. Mean pelvis (solid line) and trunk (dotted line) rotation angle in the standing throw with run-up (black line) and jump throw (grey line) of the elite players (n=8).

Conclusion

In the present study we found significant differences in ball velocity but not in throwing accuracy between the standing throw with run-up and jump throw and different skill levels. The differences in ball velocity could be explained by a better transfer of momentum for proximal to distal that lead to differences in the maximal angular velocities. For team-handball coaches and athletes, the results of this study suggest that for team-handball players to increase performance, the players had to learn two different strategies of pelvis and trunk acceleration depending on the floor contact (standing vs. jumping) and that less experienced players should increase the trunk and shoulder internal rotation angular velocity. However, additional training studies are warranted.



**EHF Competence
Academy & Network**

EUROPEAN HANDBALL FEDERATION